

ADDENDUM NO. 1

**Valley-Wide Sports Center and
Winchester Park Accessibility Project Phase II**

March 18, 2024

This Addendum to the specifications is for the purpose of adding, clarifying, or deleting certain information to the Drawings and Specifications described above and shall be made part thereof, and subject to all applicable requirements hereunder as if originally shown and/or specified.

1. **BID DATE:** The bid date remains the same: **Thursday, March 21, 2024 at 2:00PM**

2. **CONTRACT CHANGES:**

Davis-Bacon Act Prevailing Wage Determination sheets updated.

3. **MANDATORY PRE-BID WALK-THRU ATTENDEES:**

Raymond Fernandez – Leonida Builders Inc.
Chris Casillas – Combs Plumbing
Greg Worthington – Valley-Wide Recreation
Rene Gonzales – Valley-Wide Recreation

Gregory Mills – Millsten Enterprises Inc.
Justin Schweitzer – Valley-Wide Recreation
James Edwards – Valley-Wide Recreation

4. **SUBMITTED QUESTIONS AND ANSWERS:**

No Questions Were Submitted

Sincerely,

Justin Schweitzer, Special Projects Supervisor
Valley-Wide Recreation and Park District

Riverside County, California

**VALLEY-WIDE SPORTS CENTER
AND WINCHESTER PARK
ACCESSIBILITY PROJECT PHASE II
ACCESSIBILITY PROJECT
(2024-138)**

(CDBG Project # 3.199-22 and 3.198-22)

A Community Development Block Grant (CDBG) Project*

Contents:

Specifications – Notice Inviting Bids – Bidding Requirements – Bid Forms –
Contract Forms – Conditions of Contract

Board of Directors:

Jan B. Bissell, President
Nick Schouten, Vice President
Angela D. Little, Secretary
Steve Simpson, Director
Mike Juarez, Director

District Administration:

Dean Wetter, General Manager
Justin Schweitzer (Project Contact)
James Salvador (Project Contact)

*This project is funded by the U.S. of Housing and Urban Development

TABLE OF CONTENTS

| <u>BIDDING REQUIREMENTS</u> | PAGE |
|---|--------------------|
| Notice Inviting Bids | NIB-1 thru 4 |
| Instructions to Bidders | B-1 thru B-10 |
| Proposal Package Information Sheet (READ THOROUGHLY) | PP |
| Proposal (10 days) | C3-1 |
| Bidding Sheets & Equipment & Material List | BS-1 thru BS-7 |
| Bidder's Experience Record & Resumes | BR-1 thru BR-8 |
| Designation of Subcontractors | C-5(a) thru C-5(e) |
| Public Works Contractors Registration Certification | C22-1 |
| Contractor's Licensing Statement | C6-1 |
| Non-Collusion Declaration | C7-1 |
| Worker's Compensation Insurance Certificate | C11-1 |
| Iran Contracting Act Certification | C13-1 |
| Cal/OSHA Form 300A | C16-1 thru C16-2 |
| Bid Bond | BB-1 thru BB-2 |
| Special Federal Provisions | |
| Contract | C8(a) thru C8(b) |
| Insurance Requirement Memorandum | C12-1 |
| <u>SPECIAL FEDERAL PROVISIONS</u> | |
| <u>GENERAL CONDITIONS</u> | |
| Section F- Labor & Construction Includes Exhibit A-Change Order Form | F-1 thru F-56 |
| <u>SPECIAL CONDITIONS</u> | |
| <u>CONTRACT DRAWINGS/EXHIBITS</u> | |
| | SC-1 thru SC-4 |



GoRecreation.org
AWARD WINNING CALIFORNIA PARKS

901 WEST ESPLANADE AVENUE
P.O. BOX 907
SAN JACINTO, CA 92582
PHONE (951) 654-1505 · FAX (951) 654-5279

**VALLEY-WIDE SPORTS CENTER AND
WINCHESTER PARK ACCESSIBILITY PROJECT PHASE II**

NOTICE INVITING BIDS

RECEIPT AND OPENING OF PROPOSALS: Sealed bids will be received in the main office of the Valley-Wide Recreation & Park District (“District”), 901 West Esplanade Avenue, San Jacinto, CA 92582 until **Thursday, March 21, 2024 at 2:00 p.m.**, at which time or soon thereafter said bids will be opened and publicly read aloud.

Bids received after this time will be returned unopened. Bids shall be valid for sixty (60) calendar days after the bid opening date. Bids shall be submitted on the District’s Bid Forms. No electronic bids or email bids will be accepted.

SCOPE OF WORK

The work generally consists of but is not limited to accessible site improvements, removal of architectural barriers within restrooms. All finished work to conform to Americans with Disabilities Act (ADA) and California Building Code (CBC).

MANDATORY PRE-BID WALK-THROUGH

Date: **Monday, March 11, 2024 at 10:00 a.m.**

First Location: Valley-Wide Regional Park
901 W. Esplanade, Ave.
San Jacinto, CA 92583

Second Location: Francis Domenigoni Community Center
32665 Haddock St.
Winchester, CA 92596

QUESTIONS: All questions must be submitted in writing by 5:00p.m. on Thursday, March 14, 2024, to Justin Schweitzer at Justin@GoRecreation.org . **Questions received after this time may not be responded to.**

PROBABLE COST: \$280,000

COMPLETION OF WORK: All work shall be complete within **one hundred twenty (120)** calendar days after receipt of Notice-of-Acceptance-of-Proposal/Notice to Proceed. Liquidated damages of \$250.00 per calendar day will be assessed for exceeding any of the time completion requirements. Additional days will be given for days classified as “rain days” by the District Inspector.

PLANS AND SPECIFICATIONS: Copies of the Plans and Specifications are available for inspection at no cost at www.GoRecreation.org/bids-and-documents. No bid sets will be available for purchase. Plans and Specifications are also available at the following planrooms: Bid America at www.BidAmerica.com and AGC San Diego at www.agcsd.org/Departments/PlanRoom/.

GUARANTEE: Bids must be accompanied by cash, a certified or cashier’s check or a Bid Bond in favor of the Valley-Wide Recreation and Park District in an amount not less than ten percent (10%) of the submitted Total Bid Price, as a guarantee that the bidder will enter into the contract for the work, the full amount of such guarantee to be forfeited to the District should successful bidder fail to enter into said contract as set forth in Section 20160 et seq. of the Public Contract Code of the State of California.

SECURITY: Each bid shall be accompanied by the security referred to in the Contract Documents, the non-collusion affidavit, the list of proposed subcontractor, and all additional documentation required by the Instructions to Bidders. The successful bidder will be required to furnish the District with a Performance Bond equal to 100% of the successful bid, and Payment Bond equal to 100% of the successful bid, prior to execution of the Contract. All bonds are to be obtained from a surety that meets all the State of California bonding requirements, as defined in Code of Civil Procedure Section 995.120, and is admitted by the State of California. Pursuant of Public Contract Code Section 22300, the successful bidder may substitute certain securities for funds withheld by District to ensure his performance under the Contract.

INSURANCE: The successful bidder will also be required to furnish the District with an insurance policy as specified in the Specifications.

SPECIAL FEDERAL REQUIRMENTS ACKNOWLEDGEMENT: This project is being financed with Community Development Block Grant funds from the U.S. Department of Housing and Urban Development (24 CFR Part 570) and subject to certain requirements including: compliance with Section 3 (24 CFR Part 75) Economic Opportunities requirements; payment of Federal Davis-Bacon prevailing wages; Federal Labor Standards Provisions (HUD 4010); Executive Order #11246; and others. Information pertaining to the Federal requirements is on file with the County of Riverside Department of Housing Homelessness Prevention and Workforce Solutions.

FEDERAL WAGE RATES: The Federal minimum wage rate requirements, as predetermined by the Secretary of Labor, are set forth in the books issued for bidding purposes, referred to herein as Project Bid Documents (Special Federal Provisions), and in copies of this book which may be examined at the office described above where the project plans, special provisions, and proposal forms may be seen. Addenda to modify the minimum wage rates, if necessary, will be issued to holders of the Project Bid Documents.

STATE WAGE RATES: Pursuant to Section 1773 of the Labor Code, the general prevailing

wage rates, including the per diem wages applicable to the work, and for holiday and overtime work, including employer payments for health and welfare, pension, vacation, and similar purposes, in the County of Riverside in which the work is to be done, have been determined by the Director of the Department of Industrial Relations, State of California. These wages are set forth in the General Prevailing Wage Rates for this project, available from the California Department of Industrial Relations' internet website at www.dir.ca.gov and the Wage Determinations Online Program website at <http://www.wdol.gov.dba.aspx>. Future effective prevailing wage rates which have been predetermined and are on file with the California Department of Industrial Relations are referend but not printed in the general prevailing wage rates. The Contractor and any Subcontractors shall pay not less than said specified rates and shall post a copy of said wage rates at the project site. The general prevailing rate of wages by the Secretary of Labor is included in the Contract. If there is any difference between the State and Federal wage rates, the Contractor must pay the higher of the two rates. It is the responsibility of the Contractor to check the current prevailing rates.

FEDERAL NON-DISCRIMINATION PROVISIONS: Bidders shall comply with the President's Executive Order No. 11246. Discrimination in employment practices on the basis of race, color, national origin, ancestry, sex, age or religion is prohibited.

FEDERAL INTEREST EXCLUSION: Any contract or contracts awarded under this Notice Inviting Bids are expected to be funded in part by a grant from the United States Government. Neither the United States nor any of its departments, agencies, or employees is or will be a party to this Notice Inviting Bids or any resulting Agreement. This procurement will be subject to regulations contained in 40 CFR Par 33 and 35.

CONTRACT TIME: No bid or bid security may be withdrawn for seventy-five (75) calendar days after the date bids are received. The successful bidder shall within ten (10) calendar days after the District mails a Notice of Acceptance of bid, return the signed contract and bonds, and attend the pre-construction conference at the District's Administration office. The contract period shall commence twenty (20) calendar days from the date of the Notice to Proceed. The Contractor shall complete all work including testing, within one hundred twenty (120) Calendar days.

REQUIRED CONTRACTOR LICENSE: Bidders on this work will be required to be licensed by the State of California as **Class A General Engineering Contractor, Class B General Building Contractor or Class C-36 Plumbing Contractor** at the time of the bid and at the time of award as such license is defined in Section 7056 and/or Section 7058 of the Business and Professional Code and Section 732 of the California Administrative Code.

AWARD OF CONTRACT: The District shall award the Contract for the Project to the lowest responsible bidder as determined from the base bid alone by the district. The District reserves the right to reject any or all bids or to waive an irregularities or information in any bids or in the bidding process.

CERTIFIED PAYROLL: The winning bid contractor will be required to concurrently submit weekly certified payroll to the Department of Industrial Relations when submitting their monthly invoice payment request to Valley-Wide Recreation and Park District. The District's invoice payment policy is thirty (30) days.

ADDITIONAL INFORMATION: All inquiries shall be directed to Justin Schweitzer at

Justin@GoRecreation.org or at (951) 654-1505.

Dated this 20th day of February 2024

Justin Schweitzer
Justin Schweitzer, Special Projects Supervisor
Valley-Wide Recreation & Park District

Posted date: 2/20/2024

INSTRUCTIONS TO BIDDERS

B-01. SECURING DOCUMENTS

Bids must be submitted to the District on the Bid Forms which are a part of the Bid Package for the Project. Bid and Contract Documents may be obtained from the Administration Office at: 901 W. Esplanade Avenue, San Jacinto California, 92582 or www.GoRecreation.org/bids-and-documents, any time after **February 17, 2024**. Prospective bidders are encouraged to telephone in advance to determine the availability of Contract Documents. Any charge for the Contract Documents is stated in the Notice Inviting Bids.

The District may also make the Contract Documents available for review at one or more plan rooms, as indicated in the Notice Inviting Bids. Please Note: Prospective Bidders who choose to review the Contract Documents at a plan room must contact the District to obtain the required Contract Documents if they decide to submit a bid for the Project.

Any Addenda will be posted on www.GoRecreation.org/bids-and-documents. Failure to acknowledge addenda may make a bid nonresponsive and not eligible for award of the contract.

B-02. EXAMINATION OF SITE AND CONTRACT DOCUMENTS

At its own expense and prior to submitting its Bid, each Bidder shall visit the site of the proposed work and fully acquaint itself with the conditions relating to the construction and labor required so that the Bidder may fully understand the work, including but not limited to difficulties and restrictions attending the execution of the work under the contract. Each Bidder shall carefully examine the Drawings, and shall read the Specifications, Contract, and all other documents referenced herein. Each Bidder shall also determine the local conditions which may in any way affect the performance of the work, including local tax structure, contractors' licensing requirements, availability of required insurance, the prevailing wages and other relevant cost factors, shall familiarize itself with all federal, state and local laws, ordinances, rules, regulations and codes affecting the performance of the work, including the cost of permits and licenses required for the work, and shall make such surveys and investigations, including investigations of subsurface or latent physical conditions at the site or where work is to be performed as may be required. Bidders are responsible for consulting the standards referenced in the Contract. The failure or omission of any Bidder to receive or examine any contract documents, forms, instruments, addenda, or other documents, or to visit the site and acquaint itself with conditions there existing shall in no way relieve any Bidder from any obligation with respect to its Bid or to the contract and no relief for error or omission will be given except as required under State law. The submission of a Bid shall be taken as conclusive evidence of compliance with this Article.

B-03. INTERPRETATION OF DRAWINGS AND DOCUMENTS

Prospective Bidders unclear as to the true meaning of any part of the Drawings, Specifications or other proposed contract documents may submit to the Engineer of the District a written request for interpretation. The prospective Bidder submitting the request is responsible for prompt delivery. Interpretation of the Drawings, Specifications or other proposed contract documents will be made only by a written addendum duly issued and a copy of such addenda will be mailed or delivered to each prospective Bidder who has purchased a set of Drawings and Specifications. The District will not be responsible for any other explanation or interpretations of the proposed documents. If a Prospective Bidders becomes aware of any errors or omissions in any part of the Contract Documents, it is the obligation of the Prospective Bidder to promptly bring it to the attention of the District.

B-04. PRE-BID WALK-THROUGH

A Mandatory Pre-Bid Walk-Through is scheduled for Friday, **March 8, 2024 @ 10:00 a.m.** to review the Project's existing conditions at the **Valley-Wide Regional Park Sports Center – 901 W. Esplanade Ave., San Jacinto, CA 92582** and **Francis Domenigoni Community Center – 32665 Haddock St., Winchester, CA 92596**. Representatives of the District and consulting engineers, if any, will be present. Questions asked by Bidders at the Pre-Bid Walk-Through not specifically addressed within the Contract Documents shall be answered in writing, and shall be sent to all Bidders present at the Pre-Bid Walk-Through. **Bids will not be accepted from any bidder who did not attend the Mandatory Pre-Bid Walk-Through.**

B-05. ADDENDA

The District reserves the right to revise the Contract Documents prior to the Bid opening date. Revisions, if any, shall be made by written Addenda. All Addenda issued by the District shall be included in the Bid and made part of the Contract Documents. Pursuant to Public Contract Code Section 4104.5, if the District issues an Addendum which includes material changes to the Project less than 72 hours prior to the deadline for submission of Bids, the District will extend the deadline for submission of Bids. The District may determine, in its sole discretion, whether an Addendum warrants postponement of the Bid submission date. Each prospective Bidder shall provide District a name, address, email address, and facsimile number to which Addenda may be sent, as well as a telephone number by which the District can contact the Bidder. Copies of Addenda will be furnished by email, facsimile, first class mail, express mail or other proper means of delivery without charge to all parties who have obtained a copy of the Contract Documents and provided such current information. Please Note: Bidders are responsible for ensuring that they have received any and all Addenda. To this end, each Bidder should contact the Valley-Wide Administration office at (951) 654-1505, or at www.GoRecreation.org/bids-and-documents, to verify that it has received all Addenda issued, if any, prior to the Bid opening. The Bidder shall indicate the Addenda received prior to bidding in the space provided in the Bid Form. Failure to indicate all Addenda may be sufficient cause for rejecting the Bid.

B-06. ALTERNATE BIDS

If alternate bid items are called for in the Contract Documents, the time required for completion of the alternate bid items has already been factored into the Contract duration and no additional Contract time will be awarded for any of the alternate bid items. The District may elect to include one or more of the alternate bid items, or to otherwise remove certain work from the Project scope of work. Accordingly, each bidder must ensure that each bid item contains a proportionate share of profit, overhead, and other costs or expenses which will be incurred by the bidder.

B-07. COMPLETION OF BID FORMS

Bids shall only be prepared using copies of the Bid Forms which are included in the Contract Documents. The use of substitute Bid Forms other than clear and correct photocopies of those provided by the District will not be permitted. Bids shall be executed by an authorized signatory as described in these Instructions to Bidders. In addition, Bidders shall fill in all blank spaces (including inserting "N/A" where applicable), and initial all interlineations, alterations, or erasures to the Bid Forms. Bidders shall neither delete, modify, nor supplement the printed matter on the Bid Forms nor make substitutions thereon. **USE OF BLACK OR BLUE INK, INDELIBLE PENCIL, OR A TYPEWRITER IS REQUIRED.** Deviations in the Bid Forms may result in the Bid being deemed non-responsive.

B-08. MODIFICATIONS OF BIDS

Each Bidder shall submit its Bid in strict conformity with the requirements of the Contract Documents. Unauthorized additions, modifications, revisions, conditions, limitations, exclusions or provisions attached to a Bid may render it non-responsive and may cause its rejection. Bidders shall not delete, modify, or supplement the printed matter on the Bid Forms, or make substitutions thereon. Oral, telephonic and electronic modifications will not be considered.

B-09. SUBCONTRACTORS

Bidder shall set forth the name, address of the place of business, and contractor license number of each subcontractor who will perform work, labor, furnish materials or render services to the bidder on said contract and each subcontractor licensed by the State of California who, under subcontract to bidder, specially fabricates and installs a portion of the Work described in the Drawings and Specifications in an amount in excess of one half of one percent (0.5%) of the total bid price, and shall indicate the portion of the work to be done by such subcontractor in accordance with Public Contract Code Section 4104.

B-10. LICENSING REQUIREMENTS

Pursuant to Business and Professions Code Section 7028.15 and Public Contract Code Section 3300, all bidders must possess proper licenses for performance of this Contract. Subcontractors must possess the appropriate licenses for each specialty subcontracted. Pursuant to Business and Professions Code Section 7028.5, the District shall consider any bid submitted by a contractor not currently licensed in accordance with state law and pursuant to the requirements found in the Contract Documents to be nonresponsive, and the District shall reject the Bid. The District shall have the right to request, and Bidders shall provide within ten (10) calendar days, evidence satisfactory to the District of all valid license(s) currently held by that Bidder and each of the Bidder's subcontractors, before awarding the Contract.

Notwithstanding anything contained herein, if the Work involves federal funds, the Contractor shall be properly licensed by the time the Contract is awarded, pursuant to the provisions of Public Contract Code section 20103.5.

B-11. BID GUARANTEE (BOND)

Each bid shall be accompanied by: (a) cash; (b) a certified or cashier's check made payable to Valley-Wide Recreation and Park District; or (c) a Bid Bond secured from a surety company satisfactory to the District, the amount of which shall not be less than ten percent (10%) of the Total Bid Price, made payable to Valley-Wide Recreation and Park District as bid security. Personal sureties and unregistered surety companies are unacceptable. The surety insurer shall be California admitted surety insurer, as defined in Code of Civil Procedure Section 995.120. The bid security shall be provided as a guarantee that within ten (10) working days after the District provides the successful bidder the Notice of Award, the successful bidder will enter into a contract and provide the necessary bonds and certificates of insurance. The bid security will be declared forfeited if the successful bidder fails to comply within said time, and District may enter into a contract with the next lowest responsive responsible bidder, or may call for new bids. No interest shall be paid on funds deposited with the District. District will return the security accompanying the bids of all unsuccessful bidders no later than 60 calendar days after award of the contract.

B-12. IRAN CONTRACTING ACT OF 2010

In accordance with Public Contract Code Section 2200 *et seq.*, the District requires that any person that submits a bid or proposal or otherwise proposes to enter into or renew a contract with the District with respect to goods or services of one million dollars (\$1,000,000) or more, certify at the time the bid is submitted or the contract is renewed, that the person is not identified on a

list created pursuant to subdivision (b) of Public Contract Code Section 2203 as a person engaging in investment activities in Iran described in subdivision (a) of Public Contract Code Section 2202.5, or as a person described in subdivision (b) of Public Contract Code Section 2202.5, as applicable.

The form of such Iran Contracting Certificate is included with the bid package and must be signed and dated under penalty of perjury.

B-13. NON-COLLUSION DECLARATION

Bidders on all public works contracts are required to submit a declaration of non-collusion with their bid. This form is included with the bid package and must be signed and dated under penalty of perjury.

B-14. PUBLIC WORKS CONTRACTOR REGISTRATION CERTIFICATION

Pursuant to Labor Code sections 1725.5 and 1771.1, all contractors and subcontractors that wish to bid on, be listed in a bid proposal, or enter into a contract to perform public work must be registered with the Department of Industrial Relations. No bid will be accepted nor any contract entered into without proof of the contractor's and subcontractors' current registration with the Department of Industrial Relations to perform public work. If awarded a contract, the bidder and its subcontractors, of any tier, shall maintain active registration with the Department of Industrial Relations for the duration of the Project. To this end, Bidder shall sign and submit with its Bid the Public Works Contractor Registration Certification on the form provided, attesting to the facts contained therein. Failure to submit this form may render the bid non-responsive. In addition, each Bidder shall provide the registration number for each listed subcontractor in the space provided in the Designation of Subcontractors form.

B-15. BIDDER INFORMATION AND EXPERIENCE FORM

Each Bidder shall complete the questionnaire provided herein and shall submit the questionnaire along with its Bid. Failure to provide all information requested within the questionnaire along with the Bid may cause the bid to be rejected as non-responsive. The District reserves the right to reject any Bid if an investigation of the information submitted does not satisfy the Engineer that the Bidder is qualified to properly carry out the terms of the contract.

B-16. WORKERS' COMPENSATION CERTIFICATION

In accordance with the provisions of Labor Code Section 3700, Contractor shall secure the payment of compensation to its employees. Contractor shall sign and file with the District the following certificate prior to performing the work under this Contract:

I am aware of the provisions of Section 3700 of the Labor Code, which require every employer to be insured against liability for workers' compensation or to undertake self-insurance in accordance with the provisions of that code, and I will comply with such provisions before commencing the performance of the work of this contract.

The form of such Workers' Compensation Certificate is included as part of this document.

B-17. SIGNING OF BIDS

All Bids submitted shall be executed by the Bidder or its authorized representative. Bidders may be asked to provide evidence in the form of an authenticated resolution of its Board of Directors or a Power of Attorney evidencing the capacity of the person signing the Bid to bind the Bidder to each Bid and to any Contract arising therefrom.

If a Bidder is a joint venture or partnership, it may be asked to submit an authenticated Power of Attorney executed by each joint venturer or partner appointing and designating one of the joint venturers or partners as a management sponsor to execute the Bid on behalf of Bidder. Only that joint venturer or partner shall execute the Bid. The Power of Attorney shall also: (1) authorize that particular joint venturer or partner to act for and bind Bidder in all matters relating to the Bid; and (2) provide that each venturer or partner shall be jointly and severally liable for any and all of the duties and obligations of Bidder assumed under the Bid and under any Contract arising therefrom. The Bid shall be executed by the designated joint venturer or partner on behalf of the joint venture or partnership in its legal name.

B-18. SUBMISSION OF SEALED BIDS

Once the Bid and supporting documents have been completed and signed as set forth herein, they shall be placed, along with the Bid Guarantee and other required materials, in a sealed envelope, addressed and delivered or mailed, postage prepaid, to the Engineering Department of the District before the time and day set for the receipt of bids. The envelope shall bear the title of the work and the name of the bidder. No oral or telephonic bids will be considered. No forms transmitted via the internet, e-mail, facsimile, or any other electronic means will be considered unless specifically authorized by the District as provided herein. Bids received after the time and day set for the receipt of bids shall be returned to the bidder unopened. The envelope shall also contain the following in the lower left-hand corner thereof:

Bid of _____ (Bidder's Name)
for the Valley-Wide Sports Center and
Winchester Park Accessibility Project Phase II

Only where expressly permitted in the Notice Inviting Bids may bidders submit their bids via electronic transmission pursuant to Public Contract Code sections 1600 and 1601. Any acceptable method(s) of electronic transmission shall be stated in the Notice Inviting Bids. District may reject any bid not strictly complying with District's designated methods for delivery.

B-19. OPENING OF BIDS

At the time and place set for the opening and reading of bids, or any time thereafter, each and every bid received prior to the time and day set for the receipt of bids will be publicly opened and read.

The District will leave unopened any Bid received after the specified date and time, and any such unopened Bid will be returned to the bidder. It is the bidder's sole responsibility to ensure that its Bid is received as specified. Bids may be submitted earlier than the date(s) and time(s) indicated.

The public reading of each bid will include the following information:

- A. The name and business location of the bidder.
- B. The nature and amount of the bid security furnished by bidder.
- C. The bid amount.

Bidders or their representatives and other interested persons may be present at the opening of the bids. The District may, in its sole discretion, elect to postpone the opening of the submitted Bids. The District reserves the right to reject any or all Bids and to waive any informality or

irregularity in any Bid.

B-20. WITHDRAWAL OF BID

Any bid may be withdrawn either personally or by written request, incurring no penalty, at any time prior to the scheduled closing time for receipt of bids. Requests to withdraw bids shall be worded so as not to reveal the amount of the original bid. Withdrawn bids may be resubmitted until the time and day set for the receipt of bids, provided that resubmitted bids are in conformance with the instructions herein.

Bids may be withdrawn after bid opening only by providing written notice to District within five (5) working days of the bid opening and in compliance with Public Contract Code Section 5100 *et seq.*, or as otherwise may be allowed with the consent of the District.

B-21. BIDDERS INTERESTED IN MORE THAN ONE BID

No Bidder shall be allowed to make, file or be interested in more than one bid for the same work unless alternate bids are specifically called for. A person, firm or corporation that has submitted a sub-proposal to a Bidder, or that has quoted prices of materials to a Bidder, is not thereby disqualified from submitting a sub-proposal or quoting prices to other bidders. No person, firm, corporation, or other entity may submit a sub-proposal to a Bidder, or quote prices of materials to a Bidder, when also submitting a prime Bid on the same Project.

B-22. SUBSTITUTION OF SECURITY

The Contract Documents call for monthly progress payments based upon the percentage of the Work completed. The District will retain a percentage of each progress payment as provided by the Contract Documents. At the request and expense of the successful Bidder, the District will substitute securities for the amount so retained in accordance with Public Contract Code Section 22300.

B-23. PREVAILING WAGES

The District has obtained from the Director of the Department of Industrial Relations the general prevailing rate of per diem wages in the locality in which this work is to be performed for each craft or type of worker needed to execute the Contract. These rates may be obtained online at <http://www.dir.ca.gov> or are available at the Valley-Wide Administration office at 901 W. Esplanade Avenue, San Jacinto, CA. Bidders are advised that a copy of these rates must be posted by the successful Bidder at the job site(s).

B-24. DEBARMENT OF CONTRACTORS AND SUBCONTRACTORS

In accordance with the provisions of the Labor Code, contractors or subcontractors may not perform work on a public works project with a subcontractor who is ineligible to perform work on a public project pursuant to Labor Code Sections 1777.1 or 1777.7. Any contract on a public works project entered into between a contractor and a debarred subcontractor is void as a matter of law. A debarred subcontractor may not receive any public money for performing work as a subcontractor on a public works contract. Any public money that is paid to a debarred subcontractor by the Contractor for the Project shall be returned to the District. The Contractor shall be responsible for the payment of wages to workers of a debarred subcontractor who has been allowed to work on the Project.

B-25. INSURANCE REQUIREMENTS

Prior to commencing work, the successful bidder shall purchase and maintain insurance as set forth in the General Conditions.

B-26. PERFORMANCE BOND AND PAYMENT BOND REQUIREMENTS

The successful bidder will be required to furnish a Labor and Material Payment Bond and a Faithful Performance Bond each in an amount equal to one hundred percent (100%) of the contract price. Each bond shall be secured from a surety company that meets all State of California bonding requirements, as defined in California Code of Civil Procedure Section 995.120 and is admitted by the State of California. Each bond shall be accompanied, upon the request of District, with all documents required by California Code of Civil Procedure Section 995.660 to the extent required by law. All bonding and insurance requirements shall be completed and submitted to District within ten (10) working days from the date the District provides the successful bidder with the Notice of Award.

B-27. SALES AND OTHER APPLICABLE TAXES, PERMITS, LICENSES AND FEES

Contractor and its subcontractors performing work under this Contract will be required to pay California sales tax and other applicable taxes, and to pay for permits, licenses and fees required by the agencies with authority in the jurisdiction in which the Work will be located, unless otherwise expressly provided by the Contract Documents.

B-28. PERMIT AND INSPECTION FEE ALLOWANCE

Notwithstanding anything contained herein, the Bid Form contains an allowance for the Contractor's cost of acquiring traffic control permits and for construction inspection fees that may be charged to the Contractor by the Agency of Jurisdiction. The allowance is included within the Bid Form to eliminate the need by bidders to research or estimate the costs of traffic control permits and construction inspection fees prior to submitting a bid. The allowance is specifically intended to account for the costs of traffic control permits and construction inspection fees charged by the local Agency of Jurisdiction only. No other costs payable by Contractor to the Agency of Jurisdiction are included within the allowance.

B-29. FILING OF BID PROTESTS

Bidders may file a "protest" of a Bid with the District's General Manager. In order for a Bidder's protest to be considered valid, the protest must:

- D. Be filed in writing within five (5) calendar days after the bid opening date;
- E. Clearly identify the specific irregularity or accusation;
- F. Clearly identify the specific District staff determination or recommendation being protested;
- G. Specify in detail the grounds for protest and the facts supporting the protest; and
- H. Include all relevant, supporting documentation with the protest at time of filing.

If the protest does not comply with each of these requirements, the District may reject the protest without further review.

If the protest is timely and complies with the above requirements, the District's General Manager, or other designated District staff member, shall review the protest, any response from the challenged Bidder(s), and all other relevant information. The General Manager will provide a written decision to the protestor.

The procedure and time limits set forth in this Article are mandatory and are the sole and exclusive

remedy in the event of a Bid protest. Failure to comply with these procedures shall constitute a failure to exhaust administrative remedies and a waiver of any right to further pursue the Bid protest, including filing a Government Code Claim or legal proceedings.

B-30. BASIS OF AWARD; BALANCED BID

The District shall award the Contract to the lowest responsible Bidder submitting a responsive Bid. The lowest Bid will be determined on the basis of the Total Bid Price. The District may reject any Bid which, in its opinion when compared to other Bids received or to the District's internal estimates, does not accurately reflect the cost to perform the Work. The District may reject as non-responsive any Bid which unevenly weights or allocates costs, including but not limited to overhead and profit to one or more particular bid items.

B-31. SECTION 3 REQUIREMENTS

U.S. Department of Housing and Urban Development (“Section 3 Requirements”)

As part of the U.S. Congress adoption of the Housing and Urban Development Act of 1968, (12 U.S.C. 1701u), “Section 3” of the findings stated that:

The employment and other economic opportunities generated by projects and activities that receive Federal housing and community development assistance offer an effective means of empowering low- and very low- income persons, particularly persons who are recipients of government assistance for housing.

The purpose of “Section 3” is to ensure that employment and other economic opportunities generated by certain HUD financial assistance shall, to the greatest extent feasible, and consistent with existing Federal, State and local laws and regulations, be directed to low- and very low-income persons, particularly those who are recipients of government assistance for housing, and to business concerns which provide economic opportunities to low- and very low-income persons.

Consistent with federal regulation found in 24 CFR 135, participation on this contract is applicable to “Section 3” requirements pursuant to 24 CFR 135.3(d), which states:

(d) Other HUD assistance and other Federal assistance. Recipients, contractors and subcontractors that receive HUD assistance, not listed in paragraph (a) of this section, or other Federal assistance, are encouraged to provide, to the greatest extent feasible, training, employment, and contracting opportunities generated by the expenditure of this assistance to low- and very low-income persons, and business concerns owned by low- and very low-income persons, or which employ low- and very low-income persons.

Section 3 requirements generally apply to contractors or subcontractors with contracts exceeding \$100,000. In anticipation of a contract in excess of \$100,000 the following guidelines shall be considered by the selected firm in its preparation of a proposal for this contract:

- The Contractor shall provide preference to low- and very low-income residents of the local community and the business that substantially employ them for new employment,

training and contracting opportunities resulting from a final contract awarded for the Project.

- The Contractor shall give preference for training and employment opportunities arising from those programs to local low-income residents “to the greatest extent feasible”.
- The Contractor, and any subcontractors, shall give preference in awarding contracts to businesses owned by or employing local, low-income residents “to the greatest extent feasible”.
- The Contractor shall make every effort to recruit, target and direct economic opportunities to Section 3 residents and businesses.

B-32. BID PREFERENCE

A bid preference is available to contract who commit to achieving the Section 3 employment or subcontracting goals, and who submit a reasonable bid. First preference will be given to a bidder who provides a reasonable bid and is a qualified Section 3 Business Concerns. Second preference will be given to a bidder who provides a reasonable bid and commits to achieving the Section 3 employment, training and subcontracting opportunity goals by submitting a written commitment. Any Section 3 business seeking a contract or subcontract must submit evidence of their availability to successfully complete the contract, including Section 3 compliance. A Section 3 Business Concern is defined as one that is 51% or more owned by Section 3 Residents; or whose permanent, full-time staff is comprised of at least 30% of Section 3 Residents; or has committed 25% of the dollar amount of its subcontracts to Section 3 Businesses. A Section 3 Resident is a public housing resident, a low-income resident of the metropolitan area, a low-income resident of the non-metropolitan county in which the Section 3 covered assistance is expended, and all low-income persons (80% AMI or less, adjusted by family size). The applicable 80% income limits are reflected on the Section 3 Resident Certification forms. Any business seeking a Section 3 contracting preference must certify that they qualify as a Section 3 business. A copy of the Section 3 Business Certification is included in the Bid Forms and shall be submitted with the Bid (if Section 3 Business Certification is claimed). In addition, Section 3 Resident Certification Form(s) included in the Bid Forms must be completed for each Section 3 resident claimed on the Section 3 Business Certification Form. Businesses that wish to receive a bid preference by committing to train/hire Section 3 Residents or subcontract 25% of the dollar amount of its subcontracts to Section 3 Businesses must complete a Section 3 Economic Opportunity Plan included in the Bid Forms. The Contractor will be required to comply with applicable provisions of Section 3 as more particularly set forth in 24 CFR Part 135, and all applicable rules and orders of HUD issued thereunder prior to the execution of any contract. The Contractor shall agree that it is under no contractual or other disability which would prevent it from complying with Section 3 requirements. Federal labor standards provisions are included in the Appendix to these Special Provisions. The requirements for Section 3 compliance must be demonstrated and submitted with a Bid. The Section 3 Bid Package Forms and Instructions is identified on the following page. For further information on complying with Section 3 requirements in your bid, refer to the Pre-Bid Meeting: Section 3 and Prevailing Wage Checklist, and “How to Respond to the Section 3 Requirement with Your Bid” documents included in the Appendix.

B-33. AWARD PROCESS

Once all Bids are opened and reviewed to determine the lowest responsive and responsible Bidder, the District Board may award the contract. The apparent successful Bidder should begin to prepare the following documents: (1) the Performance Bond; (2) the Payment Bond; and (3) the required insurance certificates and endorsements. Once the District notifies the Bidder of the award, the Bidder will have ten (10) working days from the date of this notification to execute the Contract and supply the District with all of the required documents and certifications. Regardless

of whether the Bidder supplies the required documents and certifications in a timely manner, the Contract time will begin to run twenty (20) working days from the date of the notification. Once the District receives all of the properly drafted and executed documents and certifications from the Bidder, the District shall issue a Notice to Proceed to that Bidder.

B-34. EXECUTION OF CONTRACT

As required herein the Bidder to whom an award is made shall execute the Contract in the amount determined by the Contract Documents. The District may require appropriate evidence that the persons executing the Contract are duly empowered to do so. The Contract and bond forms to be executed by the successful Bidder are included within these Specifications and shall not be detached.

B-35. QUESTIONS

Questions regarding this Notice Inviting Bids may be directed to Justin Schweitzer, at (951) 654-1505 or email at Justin@GoRecreation.org. No other members of the District's staff or District Board should be contacted about this procurement during the bidding process. Any and all inquiries and comments regarding this Bid must be communicated in writing, unless otherwise instructed by the District. The District may, in its sole discretion, disqualify any Bidder who engages in any prohibited communications.

PROPOSAL PACKAGE INFORMATION SHEET

PROJECT NAME: Valley-Wide Sports Center and Winchester Park Accessibility Project Phase II

NOTICE TO BIDDER: *The attached Proposal Package, when complete by you and returned to this District, constitutes your Bid on this project. **Please do not submit the bound copy of the specifications or addenda with your Bid.***

*The envelope enclosing the proposal **MUST** be sealed and addressed as follow:*

Regular, Express Mail, FedEx or Hand-Deliver

Valley-Wide Recreation and Park District
Attention: Justin Schweitzer
901 W. Esplanade Avenue
San Jacinto, CA 92581

*The envelope **MUST** be plainly marked in the upper left hand corner with the name and address of the bidder, and bear the words:*

Proposal for:
(Project Name)
(Date and Hour)

SIGN, COMPLETE, AND SUBMIT THE FOLLOWING:

- Proposal Sheet (C3-1) **Signature required!**
- Bidding Sheets & Equipment and Material List – (BS-1 thru 7)
- Bidder's Experience Record & Resumes of Key Personnel (BR-1 thru 8)
- Subcontractors List (C-5(d) thru (e))
- Public Works Contractor Registration Certification (C22-1) – **Attach extracts of Bidder & Subs listed on Designation of Subcontractors form. Go to: <https://efiling.dir.ca.gov/PWCR/Search>**
- Contractor's Licensing Statement (C6-1)
- Non-collusion Declaration (C7-1)
- Workers' Compensation Insurance Certificate (C11-1)
- Iran Contracting Act Certification (C13-1) **(only required if bid is over \$1 million)**
- Cal/OSHA Form 300A (C16-1 thru 2)
- Bid Guarantee (per Notice Inviting Bids and Instructions to Bidders)
If Bid Bond, must be signed By You and Your Surety Company-Surety Acknowledgement required. Notary Acknowledgement required or Surety and Contractor
- Special Federal Provisions Document Index – Submit all Required Forms

PLEASE COMPLETE AND SIGN ALL REQUIRED AREAS. SUBMIT AND ATTACH ANY ADDITIONAL DOCUMENTATION WHICH CONSTITUTES YOUR BID

**FAILURE TO COMPLETE THIS PROPOSAL PACKAGE MAY RENDER YOUR BID
"NON-RESPONSIVE"**

[*Please Remove This Information Sheet Prior to Submitting Your Bid*](#)

PROPOSAL

The undersigned hereby declares, as Bidder, that the only persons or parties interested in this proposal as principals are those named herein; that no director or any other officer or employee of the Valley-Wide Recreation District is in any manner interested directly or indirectly in this proposal or in the profits to be derived from the contract proposed to be taken; that this bid is made without any connection with any person or persons making a bid for the same purpose; that the bid is in all respects fair and without collusion or fraud; that he has read the Notice Inviting Bids (or Bidding Information) and the Instructions to Bidders and agrees to all the stipulations contained herein; that he proposes and agrees that if his bid as submitted in the attached sheets, be accepted he will contract in the form so approved and furnish the items called for in accordance with the provisions of said approved form of Agreement and the Specifications and to deliver the same within the time stipulated therein; and that he will accept in full payment therefore the prices named in said Bid Sheet.

The Bidder further agrees, that upon receipt of written notice of acceptance of the proposal with 60 days after the day of opening bids (unless otherwise specified in the Notice Inviting Bids or Bidding information) he will execute and return the Contract in accordance with the proposal as accepted and furnish the required bond(s) within **ten (10)** days from the date of mailing the Notice of Acceptance of Proposal to him at his address given below, or within such time as allowed by Valley-Wide; and that upon his failure or refusal to do so within the said time, then the certified or cashier's check or bond accompanying this bid shall become the property of and be retained by Valley-Wide as liquidated damages for such failure or refusal, and shall be deposited with the Accountant of said Valley-Wide as monies belonging to Valley-Wide; provided, that if said Bidder shall execute the Contract and furnish the required bond within the time aforesaid, his check or bond shall be returned to him thereafter.

The Bidder further declares that the surety or sureties named in the attached sheet have agreed to furnish bond in form and amount set forth in the accompanying Notice Inviting Bids (or Bidding Information) and Article 11 of the Instructions to Bidders, in the event contract is awarded on basis of this proposal.

Company: _____

Address: _____ Date: _____

By: _____
 (Print Name) Name should appear below (Signature of Owner or Officer required)

| Name(s) of Member of Firm or Officer of Corporation Authorized to enter into a binding Contract: | Address (if different from above) |
|---|-----------------------------------|
| | |
| | |
| | |

For further detail on this proposal, please contact:

| | |
|----------------|------------|
| Name: | Address: |
| Email Address: | Telephone: |

VALLEY-WIDE RECREATION
VALLEY-WIDE SPORTS CENTER AND
WINCHESTER PARK ACCESSIBILITY PROJECT PHASE II

BIDDING SHEETS

The Contractor shall construct the project under these Specifications all in conformance with the Contract Drawings listed in Section P and these Specifications

The District reserves the right to:

- A. Accept or reject any or all bids on this specification;
- B. Award Contract to the lowest qualified bidder, based on the total bid price;
- C. Waive any defects and informalities.

The District shall be the final authority with regard to whether a bid is responsive to the call for bids and to whether a bidder is a responsible bidder under the conditions of his bid, or for any reason.

The total contract price shall include all work, materials, and equipment needed to complete the project as defined in the General Conditions, Section F. The bidder shall include costs for such other items in the most appropriate category (bid item).

VALLEY-WIDE RECREATION
VALLEY-WIDE SPORTS CENTER AND
WINCHESTER PARK ACCESSIBILITY PROJECT PHASE II

BIDDING SHEETS

ADDITION OR DEDUCTION: Provision is made here for the bidder to include an addition/deduction in their bid, if desired, to reflect any last minute adjustments in process. The addition/deduction, if made, will be proportionately applied to item(s) _____ (fill in) and reflected in the unit process for payment purposes. If the addition/deduction affects more than one bid item, the proportionate application of the addition/deduction shall be mutually agreed upon by the Contract and the District at the prejob.

Person who inspected site of the proposed work as an employee of your firm: **(Representative must have inspected the jobsite and be employee on the company's payroll to be considered a responsive bidder)**

(Name)

(Date of Inspection)

VALLEY-WIDE RECREATION

**VALLEY-WIDE SPORTS CENTER AND
WINCHESTER PARK ACCESSIBILITY PROJECT PHASE II**

BIDDING SHEETS

| Bid Item | Aprox. Qty. | Unit | Description Unit Price Written in Words | Unit Price (Figures) | Total Amount (Figures) |
|----------------------------------|--------------------|-------------|---|---------------------------------|-----------------------------------|
| 1 | 1 | LS | Mobilization per Article 6 of General Conditions (not to exceed 10% of bid). _____ | \$ _____ | \$ _____ |
| Valley-Wide Sports Center | | | | | |
| 2 | 1 | LS | Demolition _____ | \$ _____ | \$ _____ |
| 3 | 1 | LS | Rough Carpentry _____ | \$ _____ | \$ _____ |
| 4 | 1 | LS | Finish Carpentry _____ | \$ _____ | \$ _____ |
| 5 | 1 | LS | Caulking and Sealants _____ | \$ _____ | \$ _____ |
| 6 | 1 | LS | Gypsum Wallboard _____ | \$ _____ | \$ _____ |
| 7 | 1 | LS | Ceramic Tile _____ | \$ _____ | \$ _____ |
| 8 | 1 | LS | Resilient Flooring and Bases _____ | \$ _____ | \$ _____ |
| 9 | 1 | LS | Painting _____ | \$ _____ | \$ _____ |

VALLEY-WIDE RECREATION

**VALLEY-WIDE SPORTS CENTER AND
WINCHESTER PARK ACCESSIBILITY PROJECT PHASE II**

BIDDING SHEETS

| Bid Item | Aprox. Qty. | Unit | Description Unit Price Written in Words | Unit Price (Figures) | Total Amount (Figures) |
|--|--------------------|-------------|--|---------------------------------|-----------------------------------|
| 10 | 1 | LS | Toilet Partitions _____ (Unit Price Written in Words) | \$ _____ | \$ _____ |
| 11 | 1 | LS | Toilet Room Accessories _____ (Unit Price Written in Words) | \$ _____ | \$ _____ |
| 12 | 1 | LS | Plumbing _____ (Unit Price Written in Words) | \$ _____ | \$ _____ |
| 13 | 1 | LS | Miscellaneous _____ (Unit Price Written in Words) | \$ _____ | \$ _____ |
| Francis Domenigoni Community Center | | | | | |
| 14 | 1 | LS | Demolition _____ (Unit Price Written in Words) | \$ _____ | \$ _____ |
| 15 | 1 | LS | Rough Carpentry _____ (Unit Price Written in Words) | \$ _____ | \$ _____ |
| 16 | 1 | LS | Caulking and Sealants _____ (Unit Price Written in Words) | \$ _____ | \$ _____ |
| 17 | 1 | LS | Metal Door Frames _____ (Unit Price Written in Words) | \$ _____ | \$ _____ |
| 18 | 1 | LS | Doors _____ (Unit Price Written in Words) | \$ _____ | \$ _____ |
| 19 | 1 | LS | Finish Hardware _____ (Unit Price Written in Words) | \$ _____ | \$ _____ |

VALLEY-WIDE RECREATION

**VALLEY-WIDE SPORTS CENTER AND
WINCHESTER PARK ACCESSIBILITY PROJECT PHASE II**

BIDDING SHEETS

| Bid Item | Aprox. Qty. | Unit | Description Unit Price Written in Words | Unit Price (Figures) | Total Amount (Figures) |
|---|--------------------|-------------|---|---------------------------------|-----------------------------------|
| 20 | 1 | LS | Gypsum Wallboard _____ (Unit Price Written in Words) | \$ _____ | \$ _____ |
| 21 | 1 | LS | Ceramic Tile _____ (Unit Price Written in Words) | \$ _____ | \$ _____ |
| 22 | 1 | LS | Resilient Florring and Bases _____ (Unit Price Written in Words) | \$ _____ | \$ _____ |
| 23 | 1 | LS | Painting _____ (Unit Price Written in Words) | \$ _____ | \$ _____ |
| 24 | 1 | LS | Toilet Partitions _____ (Unit Price Written in Words) | \$ _____ | \$ _____ |
| 25 | 1 | LS | Toilet Room Accessories _____ (Unit Price Written in Words) | \$ _____ | \$ _____ |
| 26 | 1 | LS | Plumbing _____ (Unit Price Written in Words) | \$ _____ | \$ _____ |
| 27 | 1 | LS | Electrical _____ (Unit Price Written in Words) | \$ _____ | \$ _____ |
| 28 | 1 | LS | Miscellaneous _____ (Unit Price Written in Words) | \$ _____ | \$ _____ |
| TOTAL BID AMOUNT (Bid Items 1-28) | | | | | |
| _____ (Unit Price Written in Words) | | | | \$ _____ | |

EQUIPMENT AND MATERIAL

No substitution will be permitted without written justification and the approval of the District prior to the bid opening.

PRODUCTS OF MANUFACTURERS LISTED AS EQUALS TO THOSE SPECIFIED IN THE CONTRACT DOCUMENTS MUST BE SUBMITTED FOR REVIEW AND APPROVAL BY THE DISTRICT NO LATER THAN THE TENTH (10TH) DAY PRECEDING THE DATE SET FOR RECEIPT OF BIDS.

VALLEY-WIDE RECREATION

VALLEY-WIDE SPORTS CENTER AND WINCHSESTER PARK ACCESSIBILITY PROJECT PHASE II

BIDDER'S 3-YEAR EXPERIENCE RECORD & RESUMES OF KEY PERSONNEL

All bidders must provide a **detailed three (3) year** experience record showing successful completion, as a licensed **Class A General Engineering Contractor, Class B General Building contractor, or Class C-36 Plumbing Contractor** of at least three (3) similar projects within the last **three (3)** years as follows:

- 1. Public Works**
- 2. \$100,000 or greater contract value**
- 3. Owner occupied renovation projects**
- 4. Renovation of publicly accessible areas while maintaining public access for public administration buildings, hospitals, or schools.**

Additionally, bidders must include resumes of key personnel proposed to work on this project when submitting your bid. This information will be critical in determining the most responsible bidder.

Provide client reference contact information for each of the Projects submitted.

**Failure to submit any of the above-mentioned information with your bid
“may” deem your bid non-responsive**

VALLEY-WIDE RECREATION
VALLEY-WIDE SPORTS CENTER AND
WINCHSESTER PARK ACCESSIBILITY PROJECT PHASE II

BIDDER'S 3-YEAR EXPERIENCE
RECORD & RESUMES OF KEY PERSONNEL

Bidder Information and Experience Form

ARTICLE 1. INFORMATION ABOUT BIDDER

(Indicate not applicable ("N/A") where appropriate.)

NOTE: Where Bidder is a joint venture, pages shall be duplicated and information provided for all parties to the joint venture.

1.0 Name of Bidder: _____

2.0 Type, if Entity: _____

3.0 Bidder Address: _____

Facsimile Number

Telephone Number

Email Address

4.0 How many years has Bidder's organization been in business as a Contractor?

5.0 How many years has Bidder's organization been in business under its present name? _____

5.1 Under what other or former names has Bidder's organization operated? _____

6.0 If Bidder's organization is a corporation, answer the following:

6.1 Date of Incorporation: _____

6.2 State of Incorporation: _____

6.3 President's Name: _____

6.4 Vice-President's Name(s): _____

VALLEY-WIDE RECREATION

**VALLEY-WIDE SPORTS CENTER AND
WINCHSESTER PARK ACCESSIBILITY PROJECT PHASE II**

**BIDDER'S 3-YEAR EXPERIENCE
RECORD & RESUMES OF KEY PERSONNEL**

6.5 Secretary's Name: _____

6.6 Treasurer's Name: _____

7.0 If an individual or a partnership, answer the following:

7.1 Date of Organization: _____

7.2 Name and address of all partners (state whether general or limited partnership):

8.0 If other than a corporation or partnership, describe organization and name principals:

9.0 List other states in which Bidder's organization is legally qualified to do business.

10.0 What type of work does the Bidder normally perform with its own forces?

11.0 Has Bidder ever failed to complete any work awarded to it? If so, note when, where, and why:

VALLEY-WIDE RECREATION

**VALLEY-WIDE SPORTS CENTER AND
WINCHSESTER PARK ACCESSIBILITY PROJECT PHASE II**

**BIDDER'S 3-YEAR EXPERIENCE
RECORD & RESUMES OF KEY PERSONNEL**

12.0 Within the last five years, has any officer or partner of Bidder's organization ever been an officer or partner of another organization when it failed to complete a contract? If so, attach a separate sheet of explanation:

13.0 List Trade References:

14.0 List Bank References (Bank and Branch Address):

15.0 Name of Bonding Company and Name and Address of Agent:

[REMAINDER OF THIS PAGE INTENTIONALLY LEFT BLANK]

VALLEY-WIDE RECREATION
VALLEY-WIDE SPORTS CENTER AND
WINCHSESTER PARK ACCESSIBILITY PROJECT PHASE II

BIDDER'S 3-YEAR EXPERIENCE
RECORD & RESUMES OF KEY PERSONNEL

VALLEY-WIDE RECREATION
VALLEY-WIDE SPORTS CENTER AND
WINCHSESTER PARK ACCESSIBILITY PROJECT PHASE II

BIDDER'S 3-YEAR EXPERIENCE
RECORD & RESUMES OF KEY PERSONNEL

ARTICLE 2. LIST OF CURRENT PROJECTS (BACKLOG)

[**Duplicate Page if needed for listing additional current projects.**]

| Project Name | Agency / Contact / Contact Info | Description of Bidder's Work | Completion Date | Cost of Bidder's Work |
|--------------|---------------------------------|------------------------------|-----------------|-----------------------|
| | | | | |
| | | | | |
| | | | | |
| | | | | |
| | | | | |

VALLEY-WIDE RECREATION
VALLEY-WIDE SPORTS CENTER AND
WINCHSESTER PARK ACCESSIBILITY PROJECT PHASE II

BIDDER'S 3-YEAR EXPERIENCE
RECORD & RESUMES OF KEY PERSONNEL

| | | | | |
|--|--|--|--|--|
| | | | | |
|--|--|--|--|--|

ARTICLE 3. LIST OF COMPLETED PROJECTS – LAST THREE YEARS

[**Duplicate Page if needed for listing additional completed projects.**]

Please include only those projects which are similar enough to demonstrate Bidder's ability to perform the required Work.

| Project Name | Agency / Contact / Contact Info | Description of Bidder's Work | Completion Date | Cost of Bidder's Work |
|--------------|---------------------------------|------------------------------|-----------------|-----------------------|
| | | | | |
| | | | | |
| | | | | |
| | | | | |

VALLEY-WIDE RECREATION
VALLEY-WIDE SPORTS CENTER AND
WINCHSESTER PARK ACCESSIBILITY PROJECT PHASE II

BIDDER'S 3-YEAR EXPERIENCE
RECORD & RESUMES OF KEY PERSONNEL

ARTICLE 4. EXPERIENCE AND TECHNICAL QUALIFICATIONS QUESTIONNAIRE

Personnel:

The Bidder shall identify the key personnel to be assigned to this project in a management, construction supervision or engineering capacity.

1. List each person's job title, name and percent of time to be allocated to this project:

2. Summarize each person's specialized education:

3. List each person's years of construction experience relevant to the project:

4. Summarize such experience:

Bidder agrees that personnel named in this Bid will remain on this Project until completion of all relevant Work, unless substituted by personnel of equivalent experience and qualifications approved in advance by the District.

VALLEY-WIDE RECREATION
VALLEY-WIDE SPORTS CENTER AND
WINCHSESTER PARK ACCESSIBILITY PROJECT PHASE II

BIDDER'S 3-YEAR EXPERIENCE
RECORD & RESUMES OF KEY PERSONNEL

Additional Bidder's Statements:

If the Bidder feels that there is additional information which has not been included in the questionnaire above, and which would contribute to the qualification review, it may add that information in a statement here or on an attached sheet, appropriately marked:

ARTICLE 5. VERIFICATION AND EXECUTION

These Bid Forms shall be executed only by a duly authorized official of the Bidder:

I declare under penalty of perjury under the laws of the State of California that the foregoing information is true and correct:

Name of Bidder _____

Signature _____

Name _____

Title _____

Date _____

DESIGNATION OF SUBCONTRACTORS

In compliance with the provisions of Sec. 4100-4111, inclusive, of the Public Contract Code of the State of California, and any amendments thereof, each bidder shall set forth below: (a) The name and the location of the place of business of each subcontractor who will perform work or labor or render service to the Contractor in or about the construction of the work or improvement in an amount in excess of one-half of one percent (1/2 of 1%) of the Contractor's total bid; and (b) the portion of the work which will be done by each such subcontractor.

Each subcontractor shall possess, both at the time the bid is submitted and at all times when work is performed, a valid contractor's license for the appropriate classification necessary to perform the work for which that subcontractor is listed. Each subcontractor shall be registered with the Department of Industrial Relations at time of bid and during the performance of the Contract.

If the Contractor fails to specify a subcontractor for any portion of the work to be performed under the contract in excess of one-half of one percent (1/2 of 1%) of the Contractor's total bid, he agrees that he is fully qualified to perform that work himself, and that he shall perform that work himself, and that he shall perform that portion himself.

The Contractor shall not, without the consent of the District, or unless, either: (a) Substitute any person as subcontractor in place of the subcontractor designated in the original bid; (b) Permit any such subcontract to be assigned or transferred or allow it to be performed by anyone other than the original subcontractor listed in the bid; or (c) Sublet or subcontract any portion of the work in excess of one-half of one percent (1/2 of 1%) of the Contractor's total bid as to which his original bid did not designate a subcontractor.

In the following instances, the District may consent to the substitution of another subcontractor:

- (1) When the subcontractor listed in the bid after having a reasonable opportunity to do so fails or refuses to execute the written contract which is based upon the general terms, conditions, plans and specifications of the involved project or the terms of the subcontractor's written bid when it is presented to the subcontractor by the prime subcontractor;
- (2) When the listed subcontractor becomes bankrupt or insolvent;
- (3) When the listed subcontractor fails or refuses to perform his or her subcontract;
- (4) When the listed subcontractor fails or refuses to meet the bond requirements of the prime Contractor to furnish a bond guaranteeing prompt and faithful performance of the subcontract and the payment of all claims for labor and materials furnished or used pursuant to Public Contract Code 4108;
- (5) When the prime Contractor demonstrates to the District, as set forth in Public Contract Code 4107.5 that the name of the subcontractor was listed as the result of an inadvertent clerical error;

As a condition to assert claim of clerical error, the Contractor must give written notice of the inadvertent clerical error to the District with copies to both the listed and intended subcontractor within two (2) working days of the time of the prime bid opening. The District shall consent to the substitution if the prime Contractor and both subcontractor listed in error and the intended subcontractor each submit an affidavit to the District within eight (8) working days of the time of the prime bid opening indicating that an inadvertent clerical error was made.

The District shall also consent to the substitution of the intended Contractor if affidavits are filed by both the prime Contractor and the intended Subcontractor within six (6) working days and the subcontractor claimed to be listed in error does not submit within six (6) working days a written objection to the claim to both the District and the Contractor.

However, if the listed subcontractor submits a written objection to the Contractor's claim of inadvertent clerical error within six (6) working days from the time of the prime bid opening, the District shall investigate the claims of the parties and shall hold a public hearing as described herein to determine the validity of those claims.

Any declarations submitted must be submitted under penalty of perjury by all three (3) parties and supported by testimony under oath and subject to cross-examination.

(6) When the listed Contractor is not licensed pursuant to the Contractor's license law;

(7) When the District determines that the work performed by the listed subcontractor is substantially unsatisfactory and not in substantial accordance with the plans and specifications, or that the subcontractor is substantially delaying or disrupting the progress of the work.

Prior to any substitution of a subcontractor, the District shall give notice in writing to the listed subcontractor of the request to substitute subcontractors and the reasons for the request. The notice shall be served by registered or certified mail to the last known address of the subcontractor. The listed subcontractor who has been so notified shall have five (5) working days within which to submit written objections to the substitution to the District. Failure to file these written objections shall constitute the listed subcontractor's consent to the substitution. If written objections are filed, the District shall give notice in writing of at least five (5) working days to the listed subcontractor of a hearing by the District on the Contractor's request for substitution.

The original bid need not designate a subcontractor for the performance of any change orders.

No subletting or subcontracting of any portion of the work in excess of one-half of one percent (1/2 of 1%) of the prime Contractor's total bid shall be permitted except in cases of public emergency or necessity and then only after a written finding is made by the District as a public record setting forth the facts constituting the emergency or necessity.

As used in this designation, the term subcontractor means only those subcontractors who contract directly with the prime Contractor.

If the Contractor violates any of the provisions of this section, it is deemed to have violated and breached this contract, and the District may exercise the option in its own discretion of: (1) canceling the contract; or (2) assessing the contract or a penalty in an amount of not more than ten percent (10%) of the amount of the subcontract involved, and this penalty shall be deposited in the fund out of which the prime contract is awarded. The Contractor shall be entitled to a public hearing in five (5) days notice of the time and place of the hearing.

LIST OF DESIGNATED SUBCONTRACTORS

| | |
|----------------------------|--|
| SPEC #: | |
| PROJECT TITLE: | Valley-Wide Sports Center and Winchester Park Accessibility Project Phase II |
| NAME OF CONTRACTOR: | |

In compliance with the provisions of Sec. 4100-4111, inclusive, of the Public Contract Code of the State of California, and any amendments thereof, each bidder shall set forth: the name, location of the place of business, license number, portion of the work which will be done by each subcontractor who will perform work or labor or render service to the Contractor in or about the construction of the work or improvement in an amount in excess of one-half of one percent (1/2 of 1%) of the Contractor's total bid. Each portion of Subcontracted work noted in the below table must be specific and contain all major activities associated with completion of the project, outside of the services provided by the bidding Contractor. Ambiguous and/or incomplete Subcontracted work information may deem the bid nonresponsive. **Each subcontractor shall possess, both at the time the bid is submitted and at all times when work is performed, a valid contractor's license for the appropriate classification necessary to perform the work for which that subcontractor is listed.**

BIDDER SHALL PROVIDE THE FOLLOWING INFORMATION:

Company Name, Business Address, Email Address, License No., Contractor Registration No., Subcontract Work, and % Of Total Bid

*** PLEASE WRITE LEGIBLY***

| LICENSED SUBCONTRACTOR'S NAME, BUSINESS ADDRESS, & EMAIL ADDRESS | LICENSE # | SUBCONTRACT WORK (Be Specific) | % OF TOTAL BID |
|---|------------------------------|---|-------------------|
| | CONTRACTOR REGISTRATION # | | |
| <i>Company Name:</i> | <i>License #:</i> | | |
| <i>Address:</i> | <i>DIR Registration #:</i> | | |
| <i>Email Address:</i> | | | |
| <i>Company Name:</i> | <i>License #:</i> | | |
| <i>Address:</i> | <i>DIR Registration #:</i> | | |
| <i>Email Address:</i> | | | |

| LICENSED SUBCONTRACTOR'S NAME, BUSINESS ADDRESS, & EMAIL ADDRESS | LICENSE # | SUBCONTRACT WORK <i>(Be Specific)</i> | % OF TOTAL BID |
|--|---|---|-------------------|
| <i>Company Name:</i> <hr/> <i>Address:</i> <hr/> <i>Email Address:</i> | <i>License #:</i> <hr/> <i>DIR Registration #:</i> | | |
| <i>Company Name:</i> <hr/> <i>Address:</i> <hr/> <i>Email Address:</i> | <i>License #:</i> <hr/> <i>DIR Registration #:</i> | | |
| <i>Company Name:</i> <hr/> <i>Address:</i> <hr/> <i>Email Address:</i> | <i>License #:</i> <hr/> <i>DIR Registration #:</i> | | |
| <i>Company Name:</i> <hr/> <i>Address:</i> <hr/> <i>Email Address:</i> | <i>License #:</i> <hr/> <i>DIR Registration #:</i> | | |
| <i>Company Name:</i> <hr/> <i>Address:</i> <hr/> <i>Email Address:</i> | <i>License #:</i> <hr/> <i>DIR Registration #:</i> | | |

(Do not list alternative subcontractors for the same work) (Use additional pages if needed)

Public Works Contractor Registration Certification

Pursuant to Labor Code sections 1725.5 and 1771.1

All contractors and subcontractors that wish to bid on, be listed in a bid proposal, or enter into a contract to perform public work must be registered with the Department of Industrial Relations. See <http://www.dir.ca.gov/Public-Works/PublicWorks.html> for additional information.

No bid will be accepted nor any contract entered into without proof of the contractor's and subcontractors' current registration with the Department of Industrial Relations to perform public work.

Bidder hereby certifies that it is aware of the registration requirements set forth in Labor Code sections 1725.5 and 1771.1 and is currently registered as a contractor with the Department of Industrial Relations.

Name of Bidder: _____

DIR Registration Number: _____

DIR Registration Expiration: _____

Bidder further acknowledges:

1. Bidder shall maintain a current DIR registration for the duration of the project.
2. Bidder shall include the requirements of Labor Code sections 1725.5 and 1771.1 in its contract with subcontractors and ensure that all subcontractors are registered at the time of bid opening and maintain registration status for the duration of the project.
3. Failure to submit this form or comply with any of the above requirements may result in a finding that the bid is non-responsive.

Name of Bidder _____

Signature _____

Name and Title _____

Dated _____

CONTRACTOR'S LICENSING STATEMENT

The undersigned is licensed in accordance with the laws of the State of _____ providing for the registration of contractors. The representations made herein and in the proposal documents are made under penalty of perjury. The undersigned is hereby representing that he is properly licensed both at the time that he submits a bid as well as at the time the contract is awarded, if the contract is awarded to the undersigned.

CONTRACTOR'S CLASSIFICATION _____

LICENSE NUMBER _____ **TYPE** _____ **EXPIRATION DATE** _____

A. INDIVIDUAL CONTRACTOR

| |
|---------------------------------------|
| NAME OF INDIVIDUAL CONTRACTOR: |
| BUSINESS ADDRESS: |
| PHONE NUMBER: |
| SIGNATURE OF OWNER: |

B. FIRM OR PARTNERSHIP

| | |
|--|---------------------|
| NAME OF FIRM OR PARTNERSHIP: | |
| BUSINESS ADDRESS: | |
| PHONE NUMBER: | |
| SIGNATURE(S) & TITLE OF MEMBERS SIGNING ON BEHALF OF THE PARTNERSHIP: | |
| SIGNATURE: _____ | TITLE: _____ |
| SIGNATURE: _____ | TITLE: _____ |
| SIGNATURE: _____ | TITLE: _____ |

C. CORPORATION

| | |
|--|---------------------|
| NAME OF CORPORATION: | |
| BUSINESS ADDRESS: | |
| PHONE NUMBER: | |
| SIGNATURE OF AUTHORIZED OFFICER OF CORPORATION: | |
| SIGNATURE: _____ | TITLE: _____ |

Project Title: _____

WORKERS' COMPENSATION INSURANCE CERTIFICATE

The Contractor shall execute the following form as required by the California Labor Code, Sections 1860 and 1861:

I am aware of the provisions of Section 3700 of the Labor Code which require every employer to be insured against liability for workers' compensation or to undertake self-insurance in accordance with the provisions of that code, and I will comply with such provisions before commencing the performance of the work of this contract. Date: (Contractor) By: (Signature) (Title)

Date: _____

(Contractor)

By: _____
(Signature)

(Title)

IRAN CONTRACTING ACT
(Public Contract Code sections 2202-2208)

Prior to bidding on, submitting a proposal or executing a contract or renewal for a State of California contract for goods or services of \$1,000,000 or more, a vendor must either: a) certify it is **not** on the current list of persons engaged in investment activities in Iran created by the California Department of General Services (“DGS”) pursuant to Public Contract Code section 2203(b) and is not a financial institution extending twenty million dollars (\$20,000,000) or more in credit to another person, for 45 days or more, if that other person will use the credit to provide goods or services in the energy sector in Iran and is identified on the current list of persons engaged in investment activities in Iran created by DGS; or b) demonstrate it has been exempted from the certification requirement for that solicitation or contract pursuant to Public Contract Code section 2203(c) or (d).

To comply with this requirement, please insert your vendor or financial institution name and Federal ID Number (if available) and complete **one** of the options below. Please note: California law establishes penalties for providing false certifications, including civil penalties equal to the greater of \$250,000 or twice the amount of the contract for which the false certification was made; contract termination; and three-year ineligibility to bid on contracts. (Public Contract Code section 2205.)

OPTION #1 - CERTIFICATION

I, the official named below, certify I am duly authorized to execute this certification on behalf of the vendor/financial institution identified below, and the vendor/financial institution identified below is **not** on the current list of persons engaged in investment activities in Iran created by DGS and is not a financial institution extending twenty million dollars (\$20,000,000) or more in credit to another person/vendor, for 45 days or more, if that other person/vendor will use the credit to provide goods or services in the energy sector in Iran and is identified on the current list of persons engaged in investment activities in Iran created by DGS.

| | |
|--|-----------------------------------|
| <i>Vendor Name/Financial Institution (Printed)</i> | <i>Federal ID Number (or n/a)</i> |
| <i>By (Authorized Signature)</i> | |
| <i>Printed Name and Title of Person Signing</i> | |
| <i>Date Executed</i> | <i>Executed in</i> |

OPTION #2 – EXEMPTION

Pursuant to Public Contract Code sections 2203(c) and (d), a public entity may permit a vendor/financial institution engaged in investment activities in Iran, on a case-by-case basis, to be eligible for, or to bid on, submit a proposal for, or enters into or renews, a contract for goods and services.

If you have obtained an exemption from the certification requirement under the Iran Contracting Act, please fill out the information below, and attach documentation demonstrating the exemption approval.

| | |
|--|-----------------------------------|
| <i>Vendor Name/Financial Institution (Printed)</i> | <i>Federal ID Number (or n/a)</i> |
| <i>By (Authorized Signature)</i> | |
| <i>Printed Name and Title of Person Signing</i> | <i>Date Executed</i> |

Cal/OSHA Form 300A

Annual Summary of Work-Related Injuries and Illnesses

**Bidders shall provide the most current, completed
Cal/OSHA Form 300A with their bid (blank form attached)**

Failure to submit this form “may” deem your bid non-responsive

[PAGE LEFT INTENTIONALLY BLANK]

Annual Summary of Work Related Injuries and Illnesses



All establishments covered by CCR Title 8 Section 14300 must complete this Annual Summary, even if no work-related injuries or illnesses occurred during the year. Remember to review the Log to verify that the entries are complete and accurate before completing this summary.

Using the Log, count the individual entries you made for each category. Then write the totals below, making sure you've added the entries from every page of the Log. If you had no cases, write "0."

Employees, former employees, and their representatives have the right to review the Cal/ OSHA Form 300 in its entirety. They also have limited access to the Cal/ OSHA Form 301 or its equivalent. See CCR Title 8 Section 14300.35, in Cal/ OSHA's recordkeeping rule, for further details on the access provisions for these forms.

Facility Information

Establishment name _____

Street _____

City _____ State _____ Zip _____

Industry description (e.g. Manufacturer of motor truck trailers)

Standard Industrial Classification (SIC), if known (e.g. SIC 3715)

Employment Information

(If you don't have these figures, use the optional Worksheet to estimate)

Annual average number of employees _____

Total hours worked by all employees last year _____

Sign here

Knowingly falsifying this document may result in a fine.

I certify that I have examined this document and that to the best of my knowledge the entries are true, accurate, and complete.

Company executive Title

Phone Date

Number of Cases

| Total number of deaths | Total number of cases with days away from work | Total number of cases with job transfer or restriction | Total number of other recordable cases |
|------------------------|--|--|--|
| _____ | _____ | _____ | _____ |
| (G) | (H) | (I) | (J) |

Number of Days

| Total number of days of job transfer or restriction | Total number of days away from work |
|---|-------------------------------------|
| _____ | _____ |
| (K) | (L) |

Injury and Illness Types

| Total number of... | (M) |
|----------------------------|-------|
| (1) Injuries | _____ |
| (2) Skin disorders | _____ |
| (3) Respiratory conditions | _____ |
| (4) Poisonings | _____ |
| (5) Hearing loss | _____ |
| (6) All other Illnesses | _____ |

Post this Annual Summary from February 1 to April 30 of the year following the year covered by the form.

[PAGE LEFT INTENTIONALLY BLANK]

VALLEY-WIDE RECREATION BID BOND

Bid Bond No.

KNOW ALL MEN BY THESE PRESENTS, that we _____
(Here insert full name and address or legal title of Contractor)

_____ as Principal, hereinafter called the Principal, and

_____ (Here insert full name and address or legal title of Surety)

A corporation duly organized under the laws of the State of _____ as Surety,
Hereinafter call the Surety, are held and firmly bound unto Valley-Wide Recreation.

Obligee, hereinafter all the Obligee, in the sum of _____

_____ Dollars (_____),
for the payment of which sum well and truly to be made, the said Principal and the said Surety, bind ourselves,
our heir, executors, administrator, successors and assigns, jointly and severally firmly by these presents.

WHEREAS, the Principal has submitted a bid, dated _____, 20____, for _____

_____ (Here insert full name, address and description of Project)

NOW, THEREFORE, IF THE Obligee shall accept the bid of the Principal and the Principal shall enters into a
Contracto with the Obligee in accordance with the terms of such bid, and give such bond or bonds as may be
specified in the bidding of Contract Documents with good and sufficient surety for the faithful performance of
such Contract and for the prompt payment of labor and material furnished in the prosecution thereof, or in the
event of the failure of the Principal to enter such Contract and give such bond or bonds, if the Principal shall
pay the Obligee the difference not to exceed the penalty hereof between the amount specified in said bid and
such larger amount for which the Obligee may in good faith contract with another party to perform the Work
covered by said bid, then this obligation shall be null and void, otherwise to remain in full force and effect.

In the event suit is brought upon this Bond by Obligee and judgement is recovered , the Surety shall pay all
costs incurred by Obligee in such suits to be fixed by the court.

Signed and sealed this _____ day of _____,

(Witness)

(Principal)

(Title)

(Witness)

(Surety)

(Title)

The Bid Bond (BB-1) form shall be submitted to be considered a responsive bid

**Notary Public Acknowledgement required for Surety
Per Civil Code 1189 a notice must be legible and provided at the top in an enclosed box to be deemed responsible**

SAMPLE ALL PURPOSE ACKNOWLEDGEMENT FORM

Per Civil Code 1189 a notice must be legible and provided at the op in an enclosed box to be deemed responsive

CALIFORNIA ALL-PURPOSE ACKNOWLEDGEMENT

CIVIL CODE 1189

A notary public or other officer completing this certificate verifies only the identity of the individual who signed the document to which this certificate is attached, and not the truthfulness, accuracy, or validity of that document.

State of California

County of

PERFORMANCE BOND.

KNOW ALL PERSONS BY THESE PRESENTS:

THAT WHEREAS, the Valley-Wide Recreation and Park District, (hereinafter referred to as "District") has awarded to _____, (hereinafter referred to as the "Contractor") an agreement for the **Valley-Wide Sports Center and Winchester Park Accessibility Project Phase II** (hereinafter referred to as the "Project").

WHEREAS, the work to be performed by the Contractor is more particularly set forth in the Contract Documents for the Project dated _____, (hereinafter referred to as "Contract Documents"), the terms and conditions of which are expressly incorporated herein by reference; and

WHEREAS, the Contractor is required by said Contract Documents to perform the terms thereof and to furnish a bond for the faithful performance of said Contract Documents.

NOW, THEREFORE, we, _____, the undersigned Contractor and _____ as Surety, a corporation organized and duly authorized to transact business under the laws of the State of California, are held and firmly bound unto the District in the sum of _____ DOLLARS, (\$_____), said sum being not less than one hundred percent (100%) of the total amount of the Contract, for which amount well and truly to be made, we bind ourselves, our heirs, executors and administrators, successors and assigns, jointly and severally, firmly by these presents.

THE CONDITION OF THIS OBLIGATION IS SUCH, that, if the Contractor, his or its heirs, executors, administrators, successors or assigns, shall in all things stand to and abide by, and well and truly keep and perform the covenants, conditions and agreements in the Contract Documents and any alteration thereof made as therein provided, on its part, to be kept and performed at the time and in the manner therein specified, and in all respects according to their intent and meaning; and shall faithfully fulfill all obligations including the one (1) year guarantee of all materials and workmanship; and shall indemnify and save harmless the District, its officials, officers, employees, and authorized volunteers, as stipulated in said Contract Documents, then this obligation shall become null and void; otherwise it shall be and remain in full force and effect.

As a part of the obligation secured hereby and in addition to the face amount specified therefore, there shall be included costs and reasonable expenses and fees including reasonable attorney's fees, incurred by District in enforcing such obligation.

As a condition precedent to the satisfactory completion of the Contract Documents, unless otherwise provided for in the Contract Documents, the above obligation shall hold good for a period of one (1) year after the acceptance of the work by District, during which time if Contractor shall fail to make full, complete, and satisfactory repair and replacements and totally protect the District from loss or damage resulting from or caused by defective materials or faulty workmanship. The obligations of Surety hereunder shall continue so long as any obligation of Contractor remains. Nothing herein shall limit the District's rights or the Contractor or Surety's obligations under the Contract, law or equity, including, but not limited to, California Code of Civil Procedure Section 337.15.

Whenever Contractor shall be, and is declared by the District to be, in default under the Contract Documents, the Surety shall remedy the default pursuant to the Contract Documents, or shall promptly, at the District's option:

- i. Take over and complete the Project in accordance with all terms and conditions in the Contract Documents; or
- ii. Obtain a bid or bids for completing the Project in accordance with all terms and conditions in the Contract Documents and upon determination by Surety of the lowest responsive and responsible bidder, arrange for a Contract between such bidder, the Surety and the District, and make available as work progresses sufficient funds to pay the cost of completion of the Project, less the balance of the contract price, including other costs and damages for which Surety may be liable. The term "balance of the contract price" as used in this paragraph shall mean the total amount payable to Contractor by the District under the Contract and any modification thereto, less any amount previously paid by the District to the Contractor and any other set offs pursuant to the Contract Documents.
- iii. Permit the District to complete the Project in any manner consistent with California law and make available as work progresses sufficient funds to pay the cost of completion of the Project, less the balance of the contract price, including other costs and damages for which Surety may be liable. The term "balance of the contract price" as used in this paragraph shall mean the total amount payable to Contractor by the District under the Contract and any modification thereto, less any amount previously paid by the District to the Contractor and any other set offs pursuant to the Contract Documents.

Surety expressly agrees that the District may reject any contractor or subcontractor which may be proposed by Surety in fulfillment of its obligations in the event of default by the Contractor.

Surety shall not utilize Contractor in completing the Project nor shall Surety accept a bid from Contractor for completion of the Project if the District, when declaring the Contractor in default, notifies Surety of the District's objection to Contractor's further participation in the completion of the Project.

The Surety, for value received, hereby stipulates and agrees that no change, extension of time, alteration or addition to the terms of the Contract Documents or to the Project to be performed thereunder shall in any way affect its obligations on this bond, and it does hereby waive notice of any such change, extension of time, alteration or addition to the terms of the Contract Documents or to the Project.

IN WITNESS WHEREOF, we have hereunto set our hands and seals this _____ day of _____, 20____.

(Corporate Seal)

Contractor/ Principal

By _____

Title _____

(Corporate Seal)

Surety

By _____
Attorney-in-Fact

(Attach Attorney-in-Fact Certificate)

Title _____

The rate of premium on this bond is _____ per thousand. The total amount of premium charges is \$_____.
(The above must be filled in by corporate attorney.)

THIS IS A REQUIRED FORM

Any claims under this bond may be addressed to:

(Name and Address of Surety)

(Name and Address of Agent or Representative for service of process in California, if different from above)

(Telephone number of Surety and Agent or Representative for service of process in California)

PAYMENT BOND

KNOW ALL MEN BY THESE PRESENTS That

WHEREAS, the Valley-Wide Recreation and Park District (hereinafter designated as the "District"), by action taken or a resolution passed _____, 20____, has awarded to _____ hereinafter designated as the "Principal," a contract for the work described as follows: **Valley-Wide Sports Center and Winchester Park Accessibility Project Phase II**

WHEREAS, said Principal is required to furnish a bond in connection with said contract; providing that if said Principal or any of its Subcontractors shall fail to pay for any materials, provisions, provender, equipment, or other supplies used in, upon, for or about the performance of the work contracted to be done, or for any work or labor done thereon of any kind, or for amounts due under the Unemployment Insurance Code or for any amounts required to be deducted, withheld, and paid over to the Employment Development Department from the wages of employees of said Principal and its Subcontractors with respect to such work or labor the Surety on this bond will pay for the same to the extent hereinafter set forth.

NOW THEREFORE, we, the Principal and _____ as Surety, are held and firmly bound unto the District in the penal sum of _____ Dollars (\$ _____) lawful money of the United States of America, for the payment of which sum well and truly to be made, we bind ourselves, our heirs, executors, administrators, successors and assigns, jointly and severally, firmly by these presents.

THE CONDITION OF THIS OBLIGATION IS SUCH that if said Principal, his or its subcontractors, heirs, executors, administrators, successors or assigns, shall fail to pay any of the persons named in Civil Code Section 9100, fail to pay for any materials, provisions or other supplies, used in, upon, for or about the performance of the work contracted to be done, or for any work or labor thereon of any kind, or amounts due under the Unemployment Insurance Code with respect to work or labor performed under the contract, or for any amounts required to be deducted, withheld, and paid over to the Employment Development Department or Franchise Tax Board from the wages of employees of the contractor and his subcontractors pursuant to Revenue and Taxation Code Section 18663, with respect to such work and labor the Surety or Sureties will pay for the same, in an amount not exceeding the sum herein above specified, and also, in case suit is brought upon this bond, all litigation expenses incurred by the District in such suit, including reasonable attorneys' fees, court costs, expert witness fees and investigation expenses.

This bond shall inure to the benefit of any of the persons named in Civil Code Section 9100 so as to give a right of action to such persons or their assigns in any suit brought upon this bond.

It is further stipulated and agreed that the Surety on this bond shall not be exonerated or released from the obligation of this bond by any change, extension of time for performance, addition, alteration or modification in, to, or of any contract, plans, specifications, or agreement pertaining or relating to any scheme or work of improvement herein above described, or pertaining or relating to the furnishing of labor, materials, or equipment therefore, nor by any change or modification of any terms of payment or extension of the time for any payment pertaining or relating to any scheme or work of improvement herein above described, nor by any rescission or attempted rescission or attempted rescission of the contract, agreement or bond, nor by any conditions precedent or subsequent in the bond attempting to limit the right of recovery of claimants otherwise entitled to recover under any such contract or agreement or under the bond, nor by any

fraud practiced by any person other than the claimant seeking to recover on the bond and that this bond be construed most strongly against the Surety and in favor of all persons for whose benefit such bond is given, and under no circumstances shall Surety be released from liability to those for whose benefit such bond has been given, by reason of any breach of contract between the owner or District and original contractor or on the part of any obligee named in such bond, but the sole conditions of recovery shall be that claimant is a person described in Civil Code Section 9100, and has not been paid the full amount of his claim and that Surety does hereby waive notice of any such change, extension of time, addition, alteration or modification herein mentioned, including but not limited to the provisions of sections 2819 and 2845 of the California Civil Code.

IN WITNESS WHEREOF, we have hereunto set our hands and seals this _____ day of _____, 20__.

(Corporate Seal)

Contractor/ Principal

By _____

Title _____

(Corporate Seal)

Surety

By _____
Attorney-in-Fact

(Attach Attorney-in-Fact Certificate)

Title _____

CONTRACT

This CONTRACT, is made and entered into this ____ day of _____, 2024, by and between Valley-Wide Recreation and Park District, sometimes hereinafter called "District," and "Contractor Name", sometimes hereinafter called "Contractor."

WITNESSETH: That the parties hereto have mutually covenanted and agreed, and by these presents do covenant and agree with each other as follows:

a. **SCOPE OF WORK.** The Contractor shall perform all Work within the time stipulated in the Contract, and shall provide all labor, materials, equipment, tools, utility services, and transportation to complete all of the Work required in strict compliance with the Contract Documents as specified in Article 5, below, for the following Project:

VALLEY-WIDE SPORTS CENTER AND WINCHESTER PARK ACCESSIBILITY PROJECT PHASE II

The Contractor and its surety shall be liable to the District for any damages arising as a result of the Contractor's failure to comply with this obligation.

b. **TIME FOR COMPLETION.** Time is of the essence in the performance of the Work. The Work shall be commenced on the date stated in the District's Notice of Acceptance of Proposal / Notice to Proceed. The Contractor shall complete all Work required by the Contract Documents within one hundred eighty (180) calendar days from the commencement date stated in the Notice to Proceed. By its signature hereunder, Contractor agrees the time for completion set forth above is adequate and reasonable to complete the Work.

c. **CONTRACT PRICE.** The District shall pay to the Contractor as full compensation for the performance of the Contract, subject to any additions or deductions as provided in the Contract Documents, and including all applicable taxes and costs, the sum of "DOLLAR AMOUNT IN WORDS" (\$#####.##). Payment shall be made as set forth in the General Conditions.

d. **LIQUIDATED DAMAGES.** In accordance with Government Code section 53069.85, it is agreed that the Contractor will pay the District \$250.00 for each and every calendar day of delay beyond the time prescribed in the Contract Documents for finishing the Work, as Liquidated Damages and not as a penalty or forfeiture. In the event this is not paid, the Contractor agrees the District may deduct that amount from any money due or that may become due the Contractor under the Contract. This Article does not exclude recovery of other damages specified in the Contract Documents.

e. **COMPONENT PARTS OF THE CONTRACT.** The "Contract Documents" include the following:

- Notice Inviting Bids
- Instructions to Bidders
- Bid Form
- Bid Bond
- Designation of Subcontractors
- Information Required of Bidders
- Non-Collusion Declaration Form

Iran Contracting Act Certification
Public Works Contractor Registration Certification
Performance Bond
Payment (Labor and Materials) Bond
General Conditions
Special Conditions
Technical Specifications
Addenda
Plans and Drawings
Standard Specifications for Public Works Construction "Greenbook", latest edition, Except Sections 1-9
Applicable Local Agency Standards and Specifications, as last revised
Approved and fully executed change orders
Any other documents contained in or incorporated into the Contract

The Contractor shall complete the Work in strict accordance with all of the Contract Documents.

All of the Contract Documents are intended to be complementary. Work required by one of the Contract Documents and not by others shall be done as if required by all. This Contract shall supersede any prior agreement of the parties.

f. **PROVISIONS REQUIRED BY LAW AND CONTRACTOR COMPLIANCE.** Each and every provision of law required to be included in these Contract Documents shall be deemed to be included in these Contract Documents. The Contractor shall comply with all requirements of applicable federal, state and local laws, rules and regulations, including, but not limited to, the provisions of the California Labor Code and California Public Contract Code which are applicable to this Work.

g. **INDEMNIFICATION.** Contractor shall provide indemnification and defense as set forth in the General Conditions.

h. **PREVAILING WAGES.** Contractor shall be required to pay the prevailing rate of wages in accordance with the Labor Code which such rates shall be made available at the District's Administrative Office or may be obtained online at <http://www.dir.ca.gov> and which must be posted at the job site.

[REMAINDER OF PAGE LEFT INTENTIONALLY BLANK]

IN WITNESS WHEREOF, this Contract has been duly executed by the above-named parties, on the day and year above written.

CONTRACTOR NAME

Name of Contractor

**VALLEY-WIDE RECREATION AND
PARK DISTRICT**

By _____

By _____
Dean Wetter, General Manager

Name and Title:

Date:

License No.

Date:

**(CONTRACTOR'S SIGNATURE MUST BE
NOTARIZED AND CORPORATE
SEAL AFFIXED, IF APPLICABLE)**

Approved as to form this _____ day of _____ 20____.

Attorney for Valley-Wide Recreation and
Park District

END OF CONTRACT

MEMORANDUM



VALLEY-WIDE
RECREATION AND PARK DISTRICT

GoRecreation.org
AWARD WINNING CALIFORNIA PARKS

TO: Whom It May Concern

FROM: Valley-Wide Recreation and Park District

SUBJECT: Insurance Requirements

Insurance: Each group needs to provide Valley-Wide Recreation and Park District with a Certificate of Insurance naming **Valley-Wide Recreation and Park District** as Additional Insured, (\$1,000,000 General Liability Limit with a \$2,000,000 General Aggregate Limit). Also, must include **Form Number CG2010, Additional Endorsement** with Valley-Wide Recreation and Park District listed as Additional Insured. (Or applicable approved form from the Insurance Carrier.) **A minimum of 10 Days' Notice of Cancellation is required.**

ALSO: Please have the statement: "**Throughout Various Valley-Wide Recreation Facilities**" added to the Description of Operations Box on the certificate of Insurance. (This is to cover the use of all facility sites within our District that may be requested)

Note: Anyone utilizing the facility and having alcohol present, must also include Liquor Liability Coverage on the Certificate of Insurance.

Certificate Holder and Additional Endorsement should name:

Valley-Wide Recreation & Park District
901 W. Esplanade Ave.
San Jacinto, Ca 92582

Please Note: When submitting the Certificate and Additional Endorsement forms to Valley-Wide Recreation, please include the following information on a front cover page or envelope. This will ensure that the forms will be directed to the correct Valley-Wide Recreation site and Supervisor.

Facility SITE: District Office ATTN: James Salvador

Facility Contact Number (for any questions): (951) 654-1505

Facility FAX: (951) 654-5279 Contact EMAIL: JamesS@GoRecreation.org

GENERAL CONDITIONS
Section F – Labor & Construction
Table of Contents

| | |
|---|-----|
| ARTICLE 1 - DEFINITIONS..... | F1 |
| ARTICLE 2 - CONTRACT DOCUMENTS..... | F5 |
| ARTICLE 3 - PRECONSTRUCTION AND CONSTRUCTION COMMUNICATION..... | F6 |
| ARTICLE 4 - CONTRACT DOCUMENTS: COPIES & MAINTENANCE | F6 |
| ARTICLE 5 - EXAMINATION OF DRAWINGS, SPECIFICATION & SITE WORK..... | F6 |
| ARTICLE 6 - MOBILIZATION | F7 |
| ARTICLE 7 - EXISTENCE OF UTILITIES AT THE WORK SITE | F8 |
| ARTICLE 8 - SOILS INVESTIGATIONS | F9 |
| ARTICLE 9 - CONTRACT SUPERVISION..... | F9 |
| ARTICLE 10 - WORKERS..... | F9 |
| ARTICLE 11 - INDEPENDENT CONTRACTORS..... | F10 |
| ARTICLE 12 - SUBCONTRACTS..... | F10 |
| ARTICLE 13 - VERIFICATIONS OF EMPLOYMENT ELIGIBILITY..... | F10 |
| ARTICLE 14 - REQUEST FOR SUBSTITUTION | F10 |
| ARTICLE 15 - SHOP DRAWINGS..... | F12 |
| ARTICLE 16 - SUBMITTALS..... | F12 |
| ARTICLE 17 - MATERIALS..... | F13 |
| ARTICLE 18 - PERMITS AND LICENSES..... | F13 |
| ARTICLE 19 - TRENCHES | F14 |
| ARTICLE 20 - TRAFFIC CONTROL | F15 |
| ARTICLE 21 - DIVERSION OF RECYCLEABLE WASTE MATERIALS | F16 |
| ARTICLE 22 - REMOVAL OF HAZARDOUS MATERIALS | F16 |
| ARTICLE 23 - SANITARY FACILITIES | F16 |
| ARTICLE 24 - AIR POLLUTION CONTROL..... | F16 |
| ARTICLE 25 - LAYOUT AND FIELD ENGINEERING..... | F16 |
| ARTICLE 26 - TESTS AND INSPECTIONS..... | F17 |
| ARTICLE 27 - PROTECTION OF WORK AND PROPERTY..... | F17 |
| ARTICLE 28 - CONTRACTORS MEANS AND METHODS | F18 |
| ARTICLE 29 - AUTHORIZED REPRESENTATIVES | F18 |
| ARTICLE 30 - HOURS OF WORK..... | F18 |
| ARTICLE 31 - PAYROLL RECORDS..... | F19 |
| ARTICLE 32 - PREVAILING RATES OF WAGES | F20 |
| ARTICLE 33 - PUBLIC WORKS CONTRACTOR REGISTRATION..... | F21 |
| ARTICLE 34 - EMPLOYMENT OF APPRENTICES | F21 |
| ARTICLE 35 - NONDISCRIMINATION EQUAL EMPLOYMENT OPPORTUNITY | F22 |
| ARTICLE 36 - DEBARMENT OF CONTRACTORS AND SUBCONTRACTORS..... | F22 |
| ARTICLE 37 - LABOR EMPLOYMENT SAFETY | F23 |
| ARTICLE 38 - INSURANCE..... | F23 |
| ARTICLE 39 - FORM AND PROOF OF CARRIAGE OF INSURANCE..... | F27 |
| ARTICLE 40 - TIME FOR COMPLETION AND LIQUIDATED DAMAGES..... | F28 |
| ARTICLE 41 - COST BREAKDOWN AND INVOICING | F29 |

GENERAL CONDITIONS
Section F – Labor & Construction
Table of Contents

ARTICLE 42 - PROGRESS ESTIMATES AND PAYMENTSF29
ARTICLE 43 - SECURITIES FOR MONEY WITHHELD.....F31
ARTICLE 44 - CHANGES AND EXTRA WORKF31
ARTICLE 45 - FINAL ACCEPTANCE AND PAYMENTF43
ARTICLE 46 - OCCUPANCY.....F44
ARTICLE 47 - INDEMNIFICATION.....F45
ARTICLE 48 - PROCEDURE FOR RESOLVING DISPUTES.....F46
ARTICLE 49 - DISTRICT’S RIGHT TO TERMINATE CONTRACTF47
ARTICLE 50 - WARRANTY AND GUARANTEE OF WORKF50
ARTICLE 51 - DOCUMENT RETENTION & EXAMINATION.....F53
ARTICLE 52 - SEPARATE CONTRACTSF53
ARTICLE 53 - NOTICE AND SERVICE THEREOF.....F54
ARTICLE 54 - NOTICE OF THIRD PARTY CLAIMSF54
ARTICLE 55 - STATE LICENSE BOARD NOTICE.....F54
ARTICLE 56 - INTEGRATIONF54
ARTICLE 67 - ASSIGNMENT OF CONTRACT.....F54
ARTICLE 58 - CHANGE IN NAME AND NATURE OF CONTACTOR’S LEGAL ENTITY.....F55
ARTICLE 59 - ASSISNGMENT OF ANTITRUST ACTIONSF55
ARTICLE 60 - PROHIBITED INTERESTSF55
ARTICLE 61 - CONTROLLING LAW.....F55
ARTICLE 62 - JURISDICTION; VENUEF55
ARTICLE 63 - LAWS AND REGULATIONSF55
ARTICLE 64 - PATENTSF56
ARTICLE 65 - OWNERSHIP OF CONTRACT DOCUMENTS.....F56
ARTICLE 66 - NOTICE OF TAXABLE POSSESSORYF56
ARTICLE 67 - SURVIVAL OF OBLIGATIONS.....F56

GENERAL CONDITIONS
SECTION F- LABOR AND CONSTRUCTION

ARTICLE 1 DEFINITIONS

Whenever used in the Contract Documents and printed with initial capital letters, the terms listed below will have the meanings indicated which are applicable to both the singular and plural thereof. In addition to terms specifically defined below, terms with initial capital letters in the Contract Documents include references to identified articles and paragraphs, and the titles of other documents or forms.

- A. Act of God – An earthquake of magnitude of 3.5 or higher on the Richter scale or a tidal wave.
- B. Addenda -- Written or graphic instruments issued prior to the submission of Bids which clarify, correct, or change the Contract Documents.
- C. Additional Work -- New or unforeseen work will be classified as “Additional Work” when the District’s Representative determines that it is not covered by the Contract.
- D. Applicable Laws -- The laws, statutes, ordinances, rules, codes, regulations, permits, and licenses of any kind, issued by local, state or federal governmental authorities or private authorities with jurisdiction (including utilities), to the extent they apply to the Work.
- E. Bid -- The offer or proposal of a Bidder submitted on the prescribed form setting forth the prices and other terms for the Work to be performed.
- F. Bidder -- The individual or entity who submits a Bid directly to the District.
- G. Change Order (“CO”) -- A document that authorizes an addition, deletion, or revision in the Work or an adjustment in the Contract Price or the Contract Times, issued on or after the Effective Date of the Contract, in accordance with the Contract Documents and in the form contained in the Contract Documents.
- H. Change Order Request (“COR”) -- A request made by the Contractor for an adjustment in the Contract Price and/or Contract Times as the result of a Contractor-claimed change to the Work. This term may also be referred to as a Change Order Proposal (“COP”), or Request for Change (“RFC”).
- I. District -- The Valley-Wide Recreation and Park District.
- J. District Board, Board -- The Board of Directors of the District.
- K. District’s Representative -- The individual or entity as identified in the Special Conditions to act as the District’s Representative.
- L. Claim -- A demand or assertion by the District or Contractor seeking an adjustment of Contract Price or Contract Times, or both, or other relief with respect to the terms of the Contract. A demand for money or services by a third party is not a Claim.
- M. Contract -- The entire integrated written agreement between the District and Contractor concerning the Work. “Contract” may be used interchangeably with

GENERAL CONDITIONS
SECTION F- LABOR AND CONSTRUCTION

“Agreement” in the Contract Documents. The Contract supersedes prior negotiations, representations, or agreements, whether written or oral, and includes all Contract Documents.

- N. Contract Documents -- The documents listed in Section 00 52 13, Article 5. Some documents provided by the District to the Bidders and Contractor, including but not limited to reports and drawings of subsurface and physical conditions are not Contract Documents.
- O. Contract Price -- Amount to be paid by the District to the Contractor as full compensation for the performance of the Contract and completion of the Work, subject to any additions or deductions as provided in the Contract Documents, and including all applicable taxes and costs.
- P. Contract Times -- The number of days or the dates stated in the Contract Documents to: achieve defined Milestones, if any; and to complete the Work so that it is ready for final payment.
- Q. Contractor -- The individual or entity with which the District has contracted for performance of the Work.
- R. Contractor’s Designated On-Site Representative -- The Contractor’s Designated On-Site Representative will be as identified in Section 00 72 13, Article 3 and shall not be changed without prior written consent of the District.
- S. Daily Rate -- The Daily Rate stipulated in the Contract Documents as full compensation to the Contractor due to the District’s unreasonable delay to the Project that was not contemplated by the parties.
- T. Day -- A calendar day of 24 hours measured from midnight to the next midnight.
- U. Defective Work -- Work that is unsatisfactory, faulty, or deficient; or that does not conform to the Contract Documents; or that does not meet the requirements of any inspection, reference standard, test, or approval referenced in the Contract Documents.
- V. Demobilization -- The complete dismantling and removal by the Contractor of all of the Contractor’s temporary facilities, equipment, and personnel at the Site.
- W. Drawings -- That part of the Contract Documents prepared by of the Engineer of Record which graphically shows the scope, extent, and character of the Work to be performed by Contractor. Shop Drawings and other Contractor submittals are not Drawings as so defined.
- X. Effective Date of the Contract -- The date indicated in the Contract on which it becomes effective, but if no such date is indicated, it means the date on which the Contract is signed and delivered by the last of the two parties to sign and deliver.
- Y. Engineer, whenever not qualified, shall mean the General Manager of the District, acting either directly or through properly authorized agents, such agents acting

GENERAL CONDITIONS
SECTION F- LABOR AND CONSTRUCTION

severally within the scope of the particular duties entrusted to them. On all questions concerning the acceptance of materials, machinery, the classifications of material, the execution of work, conflicting interest of the contractors performing related work and the determination of costs, the decision of the Engineer, duly authorized by the District Board, shall be binding and final upon both parties.

Z. Engineer of Record -- The individual, partnership, corporation, joint venture, or other legal entity named as such in Section 00 73 13, Article 1.1. or any succeeding entity designated by the District.

AA. Green Book -- The current edition of the Standard Specifications for Public Works Construction promulgated by the Joint Cooperative Committee of the Southern California Chapter American Public Works Association and the Southern California Districts of the Associated General Contractors of California.

BB. Hazardous Waste -- The term "Hazardous Waste" shall have the meaning provided in Section 104 of the Solid Waste Disposal Act (42 U.S.C. § 6903) as amended from time to time or, as defined in Section 25117 of the Health and Safety Code, that is required to be removed to a class I, class II, or class III disposal site in accordance with provisions of existing law, whichever is more restrictive.

CC. Holiday – The Holidays occur on:

New Year's Day - January 1
President's Day – Third Monday in February
Memorial Day - Last Monday in May
Independence Day - July 4
Labor Day - First Monday in September
Veteran's Day - November 11
Thanksgiving Day - Fourth Thursday in November
Friday after Thanksgiving
Christmas Eve – December 24
Christmas Day - December 25
Day After Christmas – December 26
New Year's Eve – December 31

If any Holiday listed above falls on a Saturday, Saturday and the preceding Friday are both Holidays. If the Holiday should fall on a Sunday, Sunday and the following Monday are both Holidays.

DD. Notice of Award -- The written notice by the District to the Successful Bidder stating that upon timely compliance by the Successful Bidder with the conditions precedent listed therein, the District will sign and deliver the Contract.

EE. Notice of Completion -- The form which may be executed by the District and recorded by the county where the Project is located constituting final acceptance of the Project.

GENERAL CONDITIONS
SECTION F- LABOR AND CONSTRUCTION

- FF. Notice to Proceed -- A written notice given by the District to Contractor fixing the date on which the Contractor may proceed with the Work and when Contract Times will commence to run.
- GG. Project -- The total construction of which the Work to be performed under the Contract Documents may be the whole, or a part.
- HH. Recyclable Waste Materials -- Materials removed from the Site which are required to be diverted to a recycling center rather than an area landfill. Recyclable Waste Materials include asphalt, concrete, brick, concrete block, and rock.
- II. Schedule of Submittals -- A schedule, prepared and maintained by Contractor, of required submittals and the time requirements to facilitate scheduled performance of related construction activities.
- JJ. Shop Drawings -- All drawings, diagrams, illustrations, schedules, and other data or information which are specifically prepared or assembled by or for Contractor and submitted by Contractor to illustrate some portion of the Work.
- KK. Specifications -- That part of the Contract Documents consisting of written requirements for materials, equipment, systems, standards and workmanship as applied to the Work, and certain administrative requirements and procedural matters applicable thereto.
- LL. Stop Payment Notice -- A written notice as defined in Civil Code section 8044.
- MM. Subcontractor -- An individual or entity other than a Contractor having a contract with any other entity than the District for performance of any portion of the Work at the Site.
- NN. Submittal -- Written and graphic information and physical samples prepared and supplied by the Contractor demonstrating various portions of the Work.
- OO. Successful Bidder -- The Bidder submitting a responsive Bid to whom the District makes an award.
- PP. Supplier -- A manufacturer, fabricator, supplier, distributor, material man, or vendor having a direct contract with Contractor or with any Subcontractor to furnish materials or equipment used in the performance of the Work or to be incorporated in the Work.
- QQ. Underground Facilities -- All underground pipelines, conduits, ducts, cables, wires, manholes, vaults, tanks, tunnels, or other such facilities or attachments, and any encasements containing such facilities, including those that convey electricity, gases, steam, liquid petroleum products, telephone or other communications, cable television, water, wastewater, storm water, other liquids or chemicals, or traffic or other control systems.

GENERAL CONDITIONS
SECTION F- LABOR AND CONSTRUCTION

- RR. Unit Price Work -- Work to be paid for on the basis of unit prices as provided by the Contractor in its bid or as adjusted in accordance with the Contract Documents.
- SS. Warranty -- A written guarantee provided to the District by the Contractor that the Work will remain free of defects and suitable for its intended use for the period required by the Contract Documents or the longest period permitted by the law of this State, whichever is longer.
- TT. Work -- The entire construction or the various separately identifiable parts thereof required to be provided under the Contract Documents. Work includes and is the result of performing or providing all labor, services, and documentation necessary to produce such construction, and furnishing, installing, and incorporating all materials and equipment into such construction, all as required by the Contract Documents.

ARTICLE 2 CONTRACT DOCUMENTS

- A. **Contract Documents.** The Contract Documents are complementary, and what is called for by one shall be as binding as if called for by all.
- B. **Interpretations.** The Contract Documents are intended to be fully cooperative and complementary. If the Contractor observes that any documents are in conflict, the Contractor shall promptly notify the Engineer in writing. In case of conflicts between the Contract Documents, the order of precedence shall be as follows:

Change Orders

1. Addenda
2. Special Conditions
3. Technical Specifications
4. Plans (Contract Drawings)
5. Contract
6. General Conditions
7. Instructions to Bidders
8. Notice Inviting Bids
9. Contractor's Bid Forms
10. Standard Specifications for Public Works Construction (Sections 1-9 Excluded)
11. Applicable Local Agency Standards and Specifications
12. Standard Drawings
13. Reference Documents

With reference to the Drawings, the order of precedence shall be as follows:

1. Figures govern over scaled dimensions
2. Detail drawings govern over general drawings
3. Addenda or Change Order drawings govern over Contract Drawings
4. Contract Drawings govern over Standard Drawings
5. Contract Drawings govern over Shop Drawings

GENERAL CONDITIONS
SECTION F- LABOR AND CONSTRUCTION

- C. **Conflicts in Contract Documents.** Notwithstanding the orders of precedence established above, in the event of conflicts, the higher standard, higher quality, and most expensive shall always apply.
- D. **Organization of Contract Documents.** Organization of the Contract Documents into divisions, sections, and articles, and arrangement of drawings shall not control the Contractor in dividing Project Work among subcontractors or in establishing the extent of Work to be performed by any trade.

ARTICLE 3 PRECONSTRUCTION AND CONSTRUCTION COMMUNICATION

Before any Work at the site is started, a conference attended by the District, Contractor, District's Representative, and others as appropriate will be held to establish a working understanding among the parties as to the Work and to discuss the schedules referred to herein, procedures for handling Shop Drawings and other submittals, processing Applications for Payment, and maintaining required records.

At this conference the District and Contractor each shall designate, in writing, a specific individual to act as its authorized representative with respect to the services and responsibilities under the Contract. Such individuals shall have the authority to transmit instructions, receive information, render decisions relative to the Contract, and otherwise act on behalf of each respective party.

ARTICLE 4 CONTRACT DOCUMENTS: COPIES & MAINTENANCE

Contractor will be furnished, free of charge, **two (2)** copies of the Contract Documents. Additional copies may be obtained at cost of reproduction.

Contractor shall maintain a clean, undamaged set of Contract Documents, including submittals, at the Project site.

ARTICLE 5 EXAMINATION OF DRAWINGS, SPECIFICATIONS AND SITE OF WORK

- A. **Examination of Contract Documents.** Before commencing any portion of the Work, Contractor shall again carefully examine all applicable Contract Documents, the Project site, and other information given to Contractor as to materials and methods of construction and other Project requirements. Contractor shall immediately notify the Engineer of any potential error, inconsistency, ambiguity, conflict, or lack of detail or explanation. If Contractor performs, permits, or causes the performance of any Work which is in error, inconsistent or ambiguous, or not sufficiently detailed or explained, Contractor shall bear any and all resulting costs, including, without limitation, the cost of correction. In no case shall the Contractor or any subcontractor proceed with Work if uncertain as to the applicable requirements.
- B. **Additional Instructions.** After notification of any error, inconsistency, ambiguity, conflict, or lack of detail or explanation, the Engineer will provide any required additional instructions, by means of drawings or other written direction, necessary for proper execution of Work.

GENERAL CONDITIONS
SECTION F- LABOR AND CONSTRUCTION

- C. **Quality of Parts, Construction and Finish.** All parts of the Work shall be of the best quality of their respective kinds and the Contractor must use all diligence to inform itself fully as to the required construction and finish.
- D. **Contractor's Variation from Contract Document Requirements.** If it is found that the Contractor has varied from the requirements of the Contract Documents including the requirement to comply with all applicable laws, ordinances, rules and regulations, the Engineer may at any time, before or after completion of the Work, order the improper Work removed, remade or replaced by the Contractor at the Contractor's expense.

ARTICLE 6 MOBILIZATION

- A. When a bid item is included in the Bid Form for mobilization, the costs of Work in advance of construction operations and not directly attributable to any specific bid item will be included in the progress estimate ("Initial Mobilization"). When no bid item is provided for "Initial Mobilization," payment for such costs will be deemed to be included in the other items of the Work.
- B. Payment for Initial Mobilization based on the lump sum provided in the Bid Form, which shall constitute full compensation for all such Work. No payment for Initial Mobilization will be made until all of the listed items have been completed to the satisfaction of the Engineer. The scope of the Work included under Initial Mobilization shall include, but shall not be limited to, the following principal items:
 - 1. Obtaining and paying for all bonds, insurance, and permits.
 - 2. Moving on to the Project site of all Contractor's plant and equipment required for the first month's operations.
 - 3. Installing temporary construction power, wiring, and lighting facilities, as applicable.
 - 4. Establishing fire protection system, as applicable.
 - 5. Developing and installing a construction water supply, if applicable.
 - 6. Providing and maintaining the field office trailers for the Contractor, if necessary, and the Engineer (if specified), complete, with all specified furnishings and utility services.
 - 7. Providing on-site sanitary facilities and potable water facilities as specified per Cal-OSHA and these Contract Documents.
 - 8. Furnishing, installing, and maintaining all storage buildings or sheds required for temporary storage of products, equipment, or materials that have not yet been installed in the Work. All such storage shall meet manufacturer's specified storage requirements, and the specific provisions of the specifications, including temperature and humidity control, if recommended by the manufacturer, and for all security.

GENERAL CONDITIONS
SECTION F- LABOR AND CONSTRUCTION

9. Arranging for and erection of Contractor's work and storage yard.
10. Posting all OSHA required notices and establishment of safety programs per Cal-OSHA.
11. Full-time presence of Contractor's superintendent at the job site as required herein.
12. Submittal of Construction Schedule as required by the Contract Documents.

ARTICLE 7 EXISTENCE OF UTILITIES AT THE WORK SITE

- A. The District has endeavored to determine the existence of utilities at the Project site from the records of the owners of known utilities in the vicinity of the Project. The positions of these utilities as derived from such records are shown on the Plans.
- B. Unless indicated otherwise on the Plans and Specifications, no excavations were made to verify the locations shown for underground utilities. The service connections to these utilities are not shown on the Plans. Water service connections may be shown on the Plans showing general locations of such connections. It shall be the responsibility of the Contractor to determine the exact location of all service connections. The Contractor shall make its own investigations, including exploratory excavations, to determine the locations and type of service connections, prior to commencing Work which could result in damage to such utilities. The Contractor shall immediately notify the District in writing of any utility discovered in a different position than shown on the Plans or which is not shown on the Plans.
- C. If applicable, all water meters, water valves, fire hydrants, electrical utility vaults, telephone vaults, gas utility valves, and other subsurface structures shall be relocated or adjusted to final grade by the Contractor. Locations of existing utilities shown on the Plans are approximate and may not be complete. The Contractor shall be responsible for coordinating its Work with all utility companies during the construction of the Work.
- D. Notwithstanding the above, pursuant to section 4215 of the Government Code, the District has the responsibility to identify, with reasonable accuracy, main or trunk line facilities on the plans and specifications. In the event that main or trunk line utility facilities are not identified with reasonable accuracy in the plans and specifications made a part of the invitation for Bids, the District shall assume the responsibility for their timely removal, relocation, or protection.
- E. Contractor, except in an emergency, shall contact the appropriate regional notification center, **Southern California Underground Service Alert** at 811 or 1-800-227-2600 or on-line at www.digalert.org at least two working days prior to commencing any excavation if the excavation will be performed in an area which is known, or reasonably should be known, to contain subsurface installations other than the underground facilities owned or operated by the District, and obtain an inquiry identification number from that notification center. No

GENERAL CONDITIONS
SECTION F- LABOR AND CONSTRUCTION

excavation shall be commenced or carried out by the Contractor unless such an inquiry identification number has been assigned to the Contractor or any subcontractor of the Contractor and the District has been given the identification number by the Contractor.

ARTICLE 8 SOILS INVESTIGATIONS

- A. Reports and Drawings. The Special Conditions identify:
1. those reports known to the District of explorations and tests of subsurface conditions at or contiguous to the site; and
 2. those drawings known to the District of physical conditions relating to existing surface or subsurface structures at the site (except Underground Facilities).
- B. Limited Reliance by Contractor on Technical Data Authorized. Contractor may rely upon the accuracy of the "technical data" contained in such reports and drawings, which were expressly not created or obtained to evaluate or assist in the evaluation of constructability, and are not Contract Documents. Contractor shall make its own interpretation of the "technical data" and shall be solely responsible for any such interpretations. Except for reliance on the accuracy of such "technical data," Contractor may not rely upon or make any claim against the District, District's Representative, or Engineer of Record, or any of their officers, directors, members, partners, employees, agents, consultants, or subcontractors, with respect to:
1. the completeness of such reports and drawings for Contractor's purposes, including without limitation any aspects of the means, methods, techniques, sequences, and procedures of construction to be employed by Contractor, and safety precautions and programs incident thereto; or
 2. other data, interpretations, opinions, conclusions and information contained in such reports or shown or indicated in such drawings; or
 3. any Contractor interpretation of or conclusion drawn from any "technical data" or any such other data, interpretations, opinions, or information.

ARTICLE 9 CONTRACTOR'S SUPERVISION

Contractor shall continuously keep at the Project site, a competent and experienced full-time Project superintendent acceptable to the District. Superintendent must be able to proficiently speak, read and write in English and shall have the authority to make decisions on behalf of the Contractor. Contractor shall continuously provide efficient supervision of the Project.

ARTICLE 10 WORKERS

- A. Contractor shall at all times enforce strict discipline and good order among its employees. Contractor shall not employ on the Project any unfit person or any one not skilled in the Work assigned to him or her.

GENERAL CONDITIONS
SECTION F- LABOR AND CONSTRUCTION

- B. Any person in the employ of the Contractor whom the District may deem incompetent or unfit shall be dismissed from the Work and shall not be employed on this Project.

ARTICLE 11 INDEPENDENT CONTRACTORS

Contractor shall be an independent contractor for the District and not an employee. Contractor understands and agrees that it and all of its employees shall not be considered officers, employees, or agents of District and are not entitled to benefits of any kind normally provided employees of District, including but not limited to, state unemployment compensation or workers' compensation. Contractor assumes full responsibility for the acts and omissions of its employees or agents related to the Work.

ARTICLE 12 SUBCONTRACTS

- A. Contractor agrees to bind every subcontractor to the terms of the Contract Documents as far as such terms are applicable to subcontractor's portion of the Work. Contractor shall be as fully responsible to the District for the acts and omissions of its subcontractors and of persons either directly or indirectly employed by its subcontractors, as Contractor is for acts and omissions of persons directly employed by Contractor. Nothing contained in these Contract Documents shall create any contractual relationship between any subcontractor and the District.
- B. The District reserves the right to accept all subcontractors. The District's acceptance of any subcontractor under this Contract shall not in any way relieve Contractor of its obligations in the Contract Documents.
- C. Prior to substituting any subcontractor listed in the Bid Forms, Contractor must comply with the requirements of the Subletting and Subcontracting Fair Practices Act pursuant to California Public Contract Code section 4100 et seq.

ARTICLE 13 VERIFICATION OF EMPLOYMENT ELIGIBILITY

By executing this Contract, Contractor verifies that it fully complies with all requirements and restrictions of state and federal law respecting the employment of undocumented aliens, including, but not limited to, the Immigration Reform and Control Act of 1986, as may be amended from time to time, and shall require all subcontractors, sub-subcontractors and consultants to comply with the same. Each person executing this Contract on behalf of Contractor verifies that he or she is a duly authorized officer of Contractor and that any of the following shall be grounds for the District to terminate the Contract for cause: (1) failure of the Contractor or its subcontractors, sub-subcontractors or consultants to meet any of the requirements provided for in this Article; (2) any misrepresentation or material omission concerning compliance with such requirements; or (3) failure to immediately remove from the Work any person found not to be in compliance with such requirements.

ARTICLE 14 REQUESTS FOR SUBSTITUTION

- A. For the purposes of this provision, the term "substitution" shall mean the substitution of any material, method or service substantially equal to or better in

GENERAL CONDITIONS
SECTION F- LABOR AND CONSTRUCTION

every respect to that indicated in the Standard Specifications or otherwise referenced herein.

- B. Pursuant to Public Contract Code section 3400(b), the District may make a finding that is described in the Notice Inviting Bids that designates certain products, things, or services by specific brand or trade name.
- C. Unless specifically designated in the Special Conditions, whenever any material, process, or article is indicated or specified by grade, patent, or proprietary name or by name of manufacturer, such specifications shall be deemed to be used for the purpose of facilitating the description of the material, process, or article desired and shall be deemed to be followed by the words "or equal." Contractor may, unless otherwise stated, offer for substitution any material, process, or article which may be substantially equal to or better in every respect to that so indicated or specified in the Contract Documents. However, the District has adopted uniform standards for certain materials, processes, and articles.
- D. The Contractor shall submit substitution requests, together with substantiating data, for substitution of any "or equal" material, process, or article no later than thirty-five (35) calendar days after award of Contract. Provisions regarding submission of substitution requests shall not in any way authorize an extension of time for the performance of this Contract. If a substitution request is rejected by the District, the Contractor shall provide the material, method or service specified herein. The District shall not be responsible for any costs incurred by the Contractor associated with substitution requests. The burden of proof as to the equality of any material, process, or article shall rest with the Contractor. The Engineer has the complete and sole discretion to determine if a material, process, or article is substantially equal to or better than that specified and to approve or reject all substitution requests.
- E. Substantiating data as described above shall include, at a minimum, the following information:
 - 1. A signed affidavit from the Contractor stating that the material, process, or article proposed as a substitution is substantially equal to or better than that specified in every way except as may be listed on the affidavit.
 - 2. Illustrations, specifications, catalog cut sheets, and any other relevant data required to prove that the material, process, or article is substantially equal to or better than that specified.
 - 3. A statement of the cost implications of the substitution being requested, indicating whether and why the proposed substitution will reduce or increase the amount of the contract.
 - 4. Information detailing the durability and lifecycle costs of the proposed substitution.
- F. Failure to submit all the required substantiating data detailed above in a timely manner so that the substitution request can be adequately reviewed may result

GENERAL CONDITIONS
SECTION F- LABOR AND CONSTRUCTION

in rejection of the substitution request. The Engineer is not obligated to review multiple submittals related the same substitution request resulting from the Contractor's failure to initially submit a complete package.

- G. Time limitations within this Article shall be strictly complied with and in no case will an extension of time for completion of the contract be granted because of Contractor's failure to provide substitution requests at the time and in the manner described herein.
- H. The Contractor shall bear the costs of all District work associated with the review of substitution requests.
- I. If substitution requests approved by the Engineer require that Contractor furnish materials, methods or services more expensive than that specified, the increased costs shall be borne by Contractor.

ARTICLE 15 SHOP DRAWINGS

- A. Contractor shall check and verify all field measurements and shall submit with such promptness as to provide adequate time for review and cause no delay in its own Work or in that of any other contractor, subcontractor, or worker on the Project, six (6) copies of all shop drawings, calculations, schedules, and materials list, and all other provisions required by the Contract Documents. Contractor shall sign all submittals affirming that submittals have been reviewed and approved by Contractor prior to submission to Engineer. Each signed submittal shall affirm that the submittal meets all the requirements of the Contract Documents except as specifically and clearly noted and listed on the transmittal letter of the submittal.
- B. Contractor shall make any corrections required by the Engineer, and file with the Engineer six (6) corrected copies each, and furnish such other copies as may be needed for completion of the Work. Engineer's acceptance of shop drawings shall not relieve Contractor from responsibility for deviations from the Contract Documents unless Contractor has, in writing, called Engineer's attention to such deviations at time of submission and has secured the Engineer's written acceptance. Engineer's acceptance of shop drawings shall not relieve Contractor from responsibility for errors in shop drawings.

ARTICLE 16 SUBMITTALS

- A. Contractor shall furnish to the Engineer for approval, prior to purchasing or commencing any Work, a log of all samples, material lists and certifications, mix designs, schedules, and other submittals, as required in the Contract Documents. The log shall indicate whether samples will be provided in accordance with other provisions of this Contract.
- B. Contractor will provide samples and submittals, together with catalogs and supporting data required by the Engineer, to the Engineer within a reasonable time period to provide for adequate review and avoid delays in the Work.

GENERAL CONDITIONS
SECTION F- LABOR AND CONSTRUCTION

- C. These requirements shall not authorize any extension of time for performance of this Contract. Engineer will check and approve such samples, but only for conformance with design concept of work and for compliance with information given in the Contract Documents. Work shall be in accordance with approved samples and submittals.

ARTICLE 17 MATERIALS

- A. Except as otherwise specifically stated in the Contract Documents, Contractor shall provide and pay for all materials, labor, tools, equipment, lights, power, transportation, superintendence, temporary constructions of every nature, and all other services and facilities of every nature whatsoever necessary to execute and complete this Contract within specified time.
- B. Unless otherwise specified, all materials shall be new and the best of their respective kinds and grades as noted and/or specified, and workmanship shall be of good quality.
- C. Materials shall be furnished in ample quantities and at such times as to ensure uninterrupted progress of the Work and shall be stored properly and protected as required by the Contract Documents. Contractor shall be entirely responsible for damage or loss by weather or other causes to materials or Work.
- D. No materials, supplies, or equipment for Work under this Contract shall be purchased subject to any chattel mortgage or under a conditional sale or other agreement by which an interest therein or in any part thereof is retained by the seller or supplier. Contractor warrants good title to all material, supplies, and equipment installed or incorporated in the Work and agrees upon completion of all work to deliver the Project, to the District free from any claims, liens, or charges.
- E. Materials shall be stored on the Project site in such manner so as not to interfere with any operations of the District or any independent contractor.
- F. Contractor shall verify all measurements, dimensions, elevations, and quantities before ordering any materials or performing any Work, and the District shall not be liable for Contractor's failure to so. No additional compensation, over and above payment for the actual quantities at the prices set out in the Bid Form, will be allowed because of differences between actual measurements, dimension, elevations and quantities and those indicated on the Plans and in the Specifications. Any difference therein shall be submitted to the Engineer for consideration before proceeding with the Work.

ARTICLE 18 PERMITS AND LICENSES

- A. District will apply and pay for the review of necessary encroachment permits for Work within the public rights-of-way. Contractor shall obtain all other necessary permits and licenses for the construction of the Project, including encroachment permits, and shall pay all fees required by law and shall comply with all laws, ordinances, rules and regulations relating to the Work and to the preservation of

GENERAL CONDITIONS
SECTION F- LABOR AND CONSTRUCTION

public health and safety. Before acceptance of the Project, the Contractor shall submit all licenses, permits, certificates of inspection and required approvals to the District.

- B. The Bid Form contains an allowance for the Contractor's cost of acquiring traffic control permits and for construction inspection fees that may be charged to the Contractor by the Agency of Jurisdiction. The allowance is included within the Bid Form to eliminate the need by bidders to research or estimate the costs of traffic control permits and construction inspection fees prior to submitting a bid. The allowance is specifically intended to account for the costs of traffic control permits and construction inspection fees charged by the local Agency of Jurisdiction only. No other costs payable by Contractor to the Agency of Jurisdiction are included within the allowance. Payment by District to Contractor under the Permit and Inspection Allowance Bid Item shall be made based on actual cost receipts only and in accordance with the provisions of these specifications.

ARTICLE 19 TRENCHES

- A. **Trenches Five Feet or More in Depth.** Contractor shall submit to the Engineer at the preconstruction meeting, a detailed plan showing the design of shoring, bracing, sloping or other provisions to be made for worker protection from hazards of caving ground during the excavation of any trench or trenches five feet or more in depth. If such plan varies from shoring system standards established by the Construction Safety Orders of the California Code of Regulations, Department of Industrial Relations, the plan shall be prepared by a California registered civil or structural engineer. The plan shall not be less effective than the shoring, bracing, sloping, or other provisions of the Construction Safety Orders, as defined in the California Code of Regulations. The Contractor shall designate in writing the "competent person" as defined in Title 8, California Code of Regulations, who shall be present at the Work Site each day that trenching/excavation is in progress. The "competent person" shall prepare and provide daily trenching/excavation inspection reports to the Engineer. Contractor shall also submit a copy of its annual California Occupational Safety and Health Administration (Cal/OSHA) trench/excavation permit.
- B. **Excavations Deeper than Four Feet.** If the Work involves excavating trenches or other excavations that extend deeper than four feet below the surface, Contractor shall promptly, and before the excavation is further disturbed, notify the District in writing of any of the following conditions:
- C. Material that the Contractor believes may be material that is hazardous waste, as defined in section 25117 of the Health and Safety Code, that is required to be removed to a Class I, Class II, or Class III disposal site in accordance with provisions of existing law.
1. Subsurface or latent physical conditions at the site differing from those indicated.

GENERAL CONDITIONS
SECTION F- LABOR AND CONSTRUCTION

2. Unknown physical conditions at the site of any unusual nature, different materially from those ordinarily encountered and generally recognized as inherent in work of the character provided for in the Contract

The District shall promptly investigate the conditions, and if it finds that the conditions do so materially differ, or do involve hazardous waste, and cause a decrease or increase in Contractor's cost of, or the time required for, performance of any part of the Work, shall issue a change order under the procedures described in the Contract Documents.

In the event that a dispute arises between the District and the Contractor as to whether the conditions materially differ, or involve hazardous waste, or cause a decrease or increase in the Contractor's cost of, or time required for, performance of any part of the Work, the Contractor shall not be excused from any scheduled completion date provided for by the Contract, but shall proceed with all Work to be performed under the Contract. Contractor shall retain any and all rights provided either by contract or by law which pertain to the resolution of disputes and protests between the parties.

ARTICLE 20 TRAFFIC CONTROL

- A. Traffic control plan(s) for the Work may be required by the Agency(s) of Jurisdiction. Traffic control plans, if required, shall be prepared at Contractor's expense, and traffic control shall be performed at Contractor's expense in accordance with the requirements of the Agency(s) of Jurisdiction. The Permit and Inspection Allowance included within the Bid Form includes the cost of required traffic control permit(s) and construction inspection by the Agency(s) of Jurisdiction only. The Permit and Inspection Allowance does not include costs for preparation of any required traffic control plans, implementation of any traffic control requirements or for any traffic signal services that may be required. Costs for traffic control plans, implementation of traffic control, or traffic signal services required by the Agency(s) of Jurisdiction shall be included in the Contractor's Bid.
- B. All warning signs and safety devices used by the Contractor to perform the Work shall conform to the requirements contained in the State of California, Department of Transportation's current edition of "Manual of Traffic Controls for Construction and Maintenance Work Zones" or to the requirements of the local agency. The Contractor shall also be responsible for all traffic control required by the agency having jurisdiction over the project on the intersecting streets. Contractor must submit a traffic control plan to the agency having jurisdiction over the project for approval prior to starting work.
- C. The Contractor's representative on the site responsible for traffic control shall produce evidence that he/she has completed training acceptable to the California Department of Transportation for safety through construction zones. All of the streets in which the Work will occur shall remain open to traffic and one lane of traffic maintained at all times unless otherwise directed by the agency of jurisdiction. Businesses and residences adjacent to the Work shall be notified forty-eight (48) hours in advance of closing of driveways. The Contractor

GENERAL CONDITIONS
SECTION F- LABOR AND CONSTRUCTION

shall make every effort to minimize the amount of public parking temporarily eliminated due to construction in areas fronting businesses. No stockpiles of pipe or other material will be allowed in traveled right-of-ways after working hours unless otherwise approved by the Engineer.

ARTICLE 21 DIVERSION OF RECYCLABLE WASTE MATERIALS

In compliance with the applicable District's waste reduction and recycling efforts, Contractor shall divert all Recyclable Waste Materials to appropriate recycling centers as required for compliance with the local jurisdiction's waste diversion ordinances. Contractor will be required to submit weight tickets and written proof of diversion with its monthly progress payment requests. Contractor shall complete and execute any certification forms required by District or other applicable agencies to document Contractor's compliance with these diversion requirements. All costs incurred for these waste diversion efforts shall be the responsibility of the Contractor.

ARTICLE 22 REMOVAL OF HAZARDOUS MATERIALS

Should Contractor encounter material reasonably believed to be polychlorinated biphenyl (PCB) or other toxic wastes and hazardous materials which have not been rendered harmless at the Project site, the Contractor shall immediately stop work at the affected Project site and shall report the condition to the District in writing. The District shall contract for any services required to directly remove and/or abate PCBs and other toxic wastes and hazardous materials, if required by the Project site(s), and shall not require the Contractor to subcontract for such services. The Work in the affected area shall not thereafter be resumed except by written agreement of the District and Contractor.

ARTICLE 23 SANITARY FACILITIES

Contractor shall provide sanitary temporary toilet buildings and hand washing facilities for the use of all workers. All toilets and hand washing facilities shall comply with local codes and ordinances. Toilets shall be kept supplied with toilet paper and shall have workable door fasteners. Toilets and hand washing facilities shall be serviced no less than once weekly and shall be present in a quantity of not less than 1 per 20 workers as required by Cal/OSHA regulations. The toilets and hand washing facilities shall be maintained in a sanitary condition at all times. Use of toilet and hand washing facilities in the Work under construction shall not be permitted. Any other Sanitary Facilities required by Cal/OSHA shall be the responsibility of the Contractor.

ARTICLE 24 AIR POLLUTION CONTROL

Contractor shall comply with all air pollution control rules, regulations, ordinances and statutes, including, but not limited to, those required by the South Coast Air Quality Management District. All containers of paint, thinner, curing compound, solvent or liquid asphalt shall be labeled to indicate that the contents fully comply with the applicable material requirements.

ARTICLE 25 LAYOUT AND FIELD ENGINEERING

All field engineering required for laying out the Work and establishing grades for earthwork operations shall be furnished by the Contractor at its expense.

GENERAL CONDITIONS
SECTION F- LABOR AND CONSTRUCTION

ARTICLE 26 TESTS AND INSPECTIONS

- A. If the Contract Documents, the Engineer, or any instructions, laws, ordinances, or public authority requires any part of the Work to be tested or Approved, Contractor shall provide the Engineer at least two (2) working days' notice of its readiness for observation or inspection. If inspection is by a public authority other than the District, Contractor shall promptly inform the District of the date fixed for such inspection. Required certificates of inspection (or similar) shall be secured by Contractor. Costs for District testing and District inspection shall be paid by the District. Costs of tests for Work found not to be in compliance shall be paid by the Contractor.
- B. If any Work is done or covered up without the required testing or approval, the Contractor shall uncover or deconstruct the Work, and the Work shall be redone after completion of the testing at the Contractor's cost in compliance with the Contract Documents.
- C. Where inspection and testing are to be conducted by an independent laboratory or agency, materials or samples of materials to be inspected or tested shall be selected by such laboratory or agency, or by the District, and not by Contractor. All tests or inspections of materials shall be made in accordance with the commonly recognized standards of national organizations.
- D. In advance of manufacture of materials to be supplied by Contractor which must be tested or inspected, Contractor shall notify the District so that the District may arrange for testing at the source of supply. Any materials which have not satisfactorily passed such testing and inspection shall not be incorporated into the Work.
- E. If the manufacture of materials to be inspected or tested will occur in a plant or location greater than sixty (60) miles from the District, the Contractor shall pay for any excessive or unusual costs associated with such testing or inspection, including but not limited to excessive travel time, standby time and required lodging.
- F. Reexamination of Work may be ordered by the District. If so ordered, Work must be uncovered or deconstructed by Contractor. If Work is found to be in accordance with the Contract Documents, the District shall pay the costs of reexamination and reconstruction. If such work is found not to be in accordance with the Contract Documents, Contractor shall pay all costs.

ARTICLE 27 PROTECTION OF WORK AND PROPERTY

- A. The Contractor shall be responsible for all damages to persons or property that occurs as a result of the Work. Contractor shall be responsible for the proper care and protection of all materials delivered and Work performed until completion and final Acceptance by the District. All Work shall be solely at the Contractor's risk. Contractor shall adequately protect adjacent property from settlement or loss of lateral support as necessary. Contractor shall comply with all applicable safety laws and building codes to prevent accidents or injury to

GENERAL CONDITIONS
SECTION F- LABOR AND CONSTRUCTION

persons on, about, or adjacent to the Project site where Work is being performed. Contractor shall erect and properly maintain at all times, as required by field conditions and progress of work, all necessary safeguards, signs, barriers, lights, and watchmen for protection of workers and the public, and shall post danger signs warning against hazards created in the course of construction.

- B. In an emergency affecting safety of life or of work or of adjoining property, Contractor, without special instruction or authorization from the Engineer, is hereby permitted to act to prevent such threatened loss or injury; and Contractor shall so act, without appeal, if so authorized or instructed by the Engineer or the District. Any compensation claimed by Contractor on account of emergency work shall be determined by and agreed upon by the District and the Contractor.

ARTICLE 28 CONTRACTOR'S MEANS AND METHODS

Contractor is solely responsible for the means and methods utilized to perform the Work. In no case shall the Contractor's means and methods deviate from commonly used industry standards.

ARTICLE 29 AUTHORIZED REPRESENTATIVES

The District shall designate representatives, who shall have the right to be present at the Project site at all times. The District may designate an inspector who shall have the right to observe all of the Contractor's Work. The inspector shall not be responsible for the Contractor's failure to carry out the Work in accordance with the Contract Documents. Contractor shall provide safe and proper facilities for such access.

ARTICLE 30 HOURS OF WORK

- A. As provided in Article 3 (commencing at section 1810), Chapter 1, Part 7, Division 2 of the Labor Code, Contractor stipulates that eight (8) hours of labor shall constitute a legal day's work. The time of service of any worker employed at any time by the Contractor or by any subcontractor on any subcontract under this Contract upon the Work or upon any part of the Work contemplated by this Contract is limited and restricted to eight (8) hours during any one calendar day and 40 hours during any one calendar week, except as hereinafter provided. Notwithstanding the provisions herein above set forth, work performed by employees of Contractor in excess of eight (8) hours per day, and 40 hours during any one week, shall be permitted upon this public work upon compensation for all hours worked in excess of eight (8) hours per day at not less than one and one-half times the basic rate of pay.
- B. The Contractor and every subcontractor shall keep an accurate record showing the name of and actual hours worked each calendar day and each calendar week by each worker employed in connection with the Work or any part of the Work contemplated by this Contract. The record shall be kept open at all reasonable hours to the inspection of the District and to the Division of Labor Law Enforcement, Department of Industrial Relations of the State of California.

GENERAL CONDITIONS
SECTION F- LABOR AND CONSTRUCTION

- C. The Contractor shall pay to the District a penalty of twenty-five dollars (\$25.00) for each worker employed in the execution of this Contract by the Contractor or by any subcontractor for each calendar day during which such worker is required or permitted to work more than eight (8) hours in any calendar day and 40 hours in any one calendar week in violation of the provisions of Article 3 (commencing at section 1810), Chapter 1, Part 7, Division 2 of the Labor Code.
- D. Any work necessary to be performed after regular working hours, or on Saturdays and Sundays or other holidays, shall be performed without additional expense to the District.
- E. District will provide inspection during normal working hours from 7:00 a.m. to 3:30 p.m. Monday through Friday. Inspection before or after this time will be charged to the Contractor as reimbursable inspection time. Inspections on weekends requires two days' notice for review and approval. Upon written request and approval the 8.5 hour working day may be changed to other limits subject to city/county ordinance.
- F. It shall be unlawful for any person to operate, permit, use, or cause to operate any of the following at the Project site, other than between the hours of 7:00 a.m. to 5:00 p.m., Monday through Friday, with no Work allowed on the District-observed holidays, unless otherwise approved by the District:
 - 1. Powered Vehicles
 - 2. Construction Equipment
 - 3. Loading and Unloading Vehicles
 - 4. Domestic Power Tools

ARTICLE 31 PAYROLL RECORDS

- A. Pursuant to Labor Code section 1776, Contractor and all subcontractors shall maintain weekly certified payroll records, showing the names, addresses, Social Security numbers, work classifications, straight time and overtime hours worked each day and week, and the actual per diem wages paid to each journeyman, apprentice, worker, or other employee employed by them in connection with the Work under this Contract. Contractor shall certify under penalty of perjury that records maintained and submitted by Contractor are true and accurate. Contractor shall also require subcontractor(s) to certify weekly payroll records under penalty of perjury.
- B. In accordance with Labor Code section 1771.4, the Contractor and each subcontractor shall furnish the certified payroll records directly to the Department of Industrial Relations ("DIR") on the specified interval and format prescribed by the DIR, which may include electronic submission. Contractor shall comply with all requirements and regulations from the DIR relating to labor compliance monitoring and enforcement.

GENERAL CONDITIONS
SECTION F- LABOR AND CONSTRUCTION

- C. The payroll records described herein shall be certified and submitted by the Contractor at a time designated by the District. The Contractor shall also provide the following:
 - 1. A certified copy of the employee's payroll records shall be made available for inspection or furnished to such employee or his or her authorized representative on request.
 - 2. A certified copy of all payroll records described herein shall be made available for inspection or furnished upon request of the DIR.
- D. Unless submitted electronically, the certified payroll records shall be on forms provided by the Division of Labor Standards Enforcement ("DLSE") of the DIR or shall contain the same information as the forms provided by the DLSE.
- E. Any copy of records made available for inspection as copies and furnished upon request to the public or any public agency, the District, the Division of Apprenticeship Standards or the Division of Labor Standards Enforcement shall be marked or obliterated in such a manner as to prevent disclosure of an individual's name, address and social security number. The name and address of the Contractor awarded the Contract or performing the contract shall not be marked or obliterated.
- F. In the event of noncompliance with the requirements of this Article, the Contractor shall have ten (10) calendar days in which to comply subsequent to receipt of written notice specifying in what respects the Contractor must comply with this Article. Should noncompliance still be evident after such 10-day period, the Contractor shall pay a penalty of one hundred dollars (\$100.00) to the District for each calendar day, or portion thereof, for each worker, until strict compliance is effectuated. Upon the request of the Division of Apprenticeship Standards or the Division of Labor Standards Enforcement, such penalties shall be withheld from progress payment then due.
- G. The responsibility for compliance with this Article shall rest upon the Contractor.

ARTICLE 32 PREVAILING RATES OF WAGES

- A. The Contractor is aware of the requirements of Labor Code sections 1720 *et seq.* and 1770 *et seq.*, as well as California Code of Regulations, Title 8, Section 16000 *et seq.* ("Prevailing Wage Laws"), which require the payment of prevailing wage rates and the performance of other requirements on certain "public works" and "maintenance" projects. Since this Project involves an applicable "public works" or "maintenance" project, as defined by the Prevailing Wage Laws, and since the total compensation is \$1,000 or more, Contractor agrees to fully comply with such Prevailing Wage Laws. The Contractor shall obtain a copy of the prevailing rates of per diem wages at the commencement of this Contract from the website of the Division of Labor Statistics and Research of the Department of Industrial Relations located at www.dir.ca.gov. In the alternative, the Contractor may view a copy of the prevailing rate of per diem wages which are on file at the District's Administration Office and shall be made available to

GENERAL CONDITIONS
SECTION F- LABOR AND CONSTRUCTION

interested parties upon request. Contractor shall make copies of the prevailing rates of per diem wages for each craft, classification, or type of worker needed to perform work on the Project available to interested parties upon request, and shall post copies at the Contractor's principal place of business and at the Project site. Contractor shall defend, indemnify and hold the District, its officials, officers, employees and authorized volunteers free and harmless from any claims, liabilities, costs, penalties or interest arising out of any failure or alleged failure to comply with the Prevailing Wage Laws.

- B. The Contractor shall forfeit as a penalty to the District not more than Two Hundred Dollars (\$200.00), pursuant to Labor Code section 1775, for each calendar day, or portion thereof, for each worker paid less than the prevailing wage rate as determined by the Director of the Department of Industrial Relations for such work or craft in which such worker is employed for any public work done under the Contract by it or by any subcontractor under it. The difference between such prevailing wage rate and the amount paid to each worker for each calendar day or portion thereof, for which each worker was paid less than the prevailing wage rate, shall be paid to each worker by the Contractor.
- C. Contractor shall post, at appropriate conspicuous points on the Project site, a schedule showing all determined general prevailing wage rates and all authorized deductions, if any, from unpaid wages actually earned.

ARTICLE 33 PUBLIC WORKS CONTRACTOR REGISTRATION

Pursuant to Labor Code sections 1725.5 and 1771.1, the Contractor and its subcontractors must be registered with the Department of Industrial Relations prior to the execution of a contract to perform public works. By entering into this Contract, Contractor represents that it is aware of the registration requirement and is currently registered with the DIR. Contractor shall maintain a current registration for the duration of the Project. Contractor shall further include the requirements of Labor Code sections 1725.5 and 1771.1 in any subcontract and ensure that all subcontractors are registered at the time this Contract is entered into and maintain registration for the duration of the Project.

ARTICLE 34 EMPLOYMENT OF APPRENTICES

- A. Contractor and all subcontractors shall comply with the requirements of Labor Code sections 1777.5 and 1777.6 in the employment of apprentices.
- B. Information relative to apprenticeship standards, wage schedules, and other requirements may be obtained from the Director of Industrial Relations, ex officio the Administrator of Apprenticeship, San Francisco, California, or from the Division of Apprenticeship Standards and its branch offices.
- C. Knowing violations of Labor Code section 1777.5 will result in forfeiture not to exceed one hundred dollars (\$100.00) for each calendar day of non-compliance pursuant to Labor Code section 1777.7.
- D. The responsibility for compliance with this Article shall rest upon the Contractor.

GENERAL CONDITIONS
SECTION F- LABOR AND CONSTRUCTION

ARTICLE 35 NONDISCRIMINATION/EQUAL EMPLOYMENT OPPORTUNITY

Pursuant to Labor Code section 1735 and other applicable provisions of law, the Contractor and its subcontractors shall not discriminate against any employee or applicant for employment because of race, religious creed, color, national origin, ancestry, physical disability, mental disability, medical condition, marital status, sex, age, sexual orientation, or any other classifications protected by law on this Project. The Contractor will take affirmative action to insure that employees are treated during employment or training without regard to their race, religious creed, color, national origin, ancestry, physical disability, mental disability, medical condition, marital status, sex, age, sexual orientation, or any other classifications protected by law.

Employment Eligibility; Contractor. By executing this Contract, Contractor verifies that it fully complies with all requirements and restrictions of state and federal law respecting the employment of undocumented aliens, including, but not limited to, the Immigration Reform and Control Act of 1986, as may be amended from time to time. Such requirements and restrictions include, but are not limited to, examination and retention of documentation confirming the identity and immigration status of each employee of the Contractor. Contractor also verifies that it has not committed a violation of any such law within the five (5) years immediately preceding the date of execution of this Contract, and shall not violate any such law at any time during the term of the Contract. Contractor shall avoid any violation of any such law during the term of this Contract by participating in an electronic verification of work authorization program operated by the United States Department of Homeland Security, by participating in an equivalent federal work authorization program operated by the United States Department of Homeland Security to verify information of newly hired employees, or by some other legally acceptable method. Contractor shall maintain records of each such verification, and shall make them available to the District or its representatives for inspection and copy at any time during normal business hours. The District shall not be responsible for any costs or expenses related to Contractor's compliance with the requirements provided for or referred to herein.

Employment Eligibility; Subcontractors, Sub-subcontractors and Consultants. To the same extent and under the same conditions as Contractor, Contractor shall require all of its subcontractors, sub-subcontractors and consultants performing any part of the Work or of this Contract to make the same verifications and comply with all requirements and restrictions provided for herein.

Employment Eligibility; Failure to Comply. Each person executing this Contract on behalf of Contractor verifies that he or she is a duly authorized officer of Contractor, and understands that any of the following shall be grounds for the District to terminate the Contract for cause: (1) failure of Contractor or its subcontractors, sub-subcontractors or consultants to meet any of the requirements provided for herein; (2) any misrepresentation or material omission concerning compliance with such requirements; or (3) failure to immediately remove from the Work any person found not to be in compliance with such requirements.

ARTICLE 36 DEBARMENT OF CONTRACTORS AND SUBCONTRACTORS

Contractors or subcontractors may not perform work on a public works project with a subcontractor who is ineligible to perform work on a public project pursuant to Labor Code section 1777.1 or 1777.7. Any contract on a public works project entered into between a contractor and a debarred subcontractor is void as a matter of law. A debarred subcontractor

GENERAL CONDITIONS
SECTION F- LABOR AND CONSTRUCTION

may not receive any public money for performing work as a subcontractor on a public works contract. Any public money that is paid, or may have been paid to a debarred subcontractor by a contractor on the project shall be returned to the District. The Contractor shall be responsible for the payment of wages to workers of a debarred subcontractor who has been allowed to work on the project.

ARTICLE 37 LABOR/EMPLOYMENT SAFETY

The Contractor shall comply with all applicable laws and regulations of the federal, state, and local government, including Cal/OSHA requirements and requirements for verification of employees' legal right to work in the United States.

The Contractor shall maintain emergency first aid treatment for his employees which complies with the Federal Occupational Safety and Health Act of 1970 (29 U.S.C. § 651 *et seq.*), and California Code of Regulations, Title 8, Industrial Relations Division 1, Department of Industrial Relations, Chapter 4. The Contractor shall ensure the availability of emergency medical services for its employees in accordance with California Code of Regulations, Title 8, Section 1512.

The Contractor shall submit the Illness and Injury Prevention Program and a Project site specific safety program to the District prior to beginning Work at the Project site. Contractor shall maintain a confined space program that meets or exceeds the District Standards. Contractor shall adhere to the District's lock out tag out program.

ARTICLE 38 INSURANCE

The Contractor shall obtain, and at all times during performance of the Work of Contract, maintain all of the insurance described in this Article. Contractor shall not commence Work under this Contract until it has provided evidence satisfactory to the District that it has secured all insurance required hereunder. Contractor shall not allow any subcontractor to commence work on any subcontract until it has provided evidence satisfactory to the District that the subcontractor has secured all insurance required under this Article. Failure to provide and maintain all required insurance shall be grounds for the District to terminate this Contract for cause. Contractor shall furnish District with original certificates of insurance and endorsements effective coverage required by this Contract on forms satisfactory to the District. The certificates and endorsements for each insurance policy shall be signed by a person authorized by that insurer to bind coverage on its behalf, and shall be on forms acceptable to the District. All certificates and endorsements must be received and approved by the District before Work commences.

- A. **Additional Insureds; Waiver of Subrogation.** The District, its officials, officers, employees, agents and authorized volunteers shall be named as Additional Insureds on Contractor's All Risk policy and on Contractor's and its subcontractors' policies of Commercial General Liability and Automobile Liability insurance using, for Contractor's policy/ies of Commercial General Liability insurance, ISO CG forms 20 10 and 20 37 (or endorsements providing the exact same coverage, including completed operations), and, for subcontractors' policies of Commercial General Liability insurance, ISO CG form 20 38 (or endorsements providing the exact same coverage). Notwithstanding the minimum limits set forth in this Contract for any type of insurance coverage, all

GENERAL CONDITIONS
SECTION F- LABOR AND CONSTRUCTION

available insurance proceeds in excess of the specified minimum limits of coverage shall be available to the parties required to be named as Additional Insureds hereunder. Contractor and its insurance carriers shall provide a Waiver of Subrogation in favor of those parties.

- B. Workers' Compensation Insurance.** The Contractor shall provide workers' compensation insurance for all of the employees engaged in Work under this Contract, on or at the Site, and, in case of any sublet Work, the Contractor shall require the subcontractor similarly to provide workers' compensation insurance for all the latter's employees as prescribed by State law. Any class of employee or employees not covered by a subcontractor's insurance shall be covered by the Contractor's insurance. In case any class of employees engaged in work under this Contract, on or at the Site, is not protected under the Workers' Compensation Statutes, the Contractor shall provide or shall cause a subcontractor to provide, adequate insurance coverage for the protection of such employees not otherwise protected. The Contractor is required to secure payment of compensation to his employees in accordance with the provisions of section 3700 of the Labor Code. The Contractor shall file with the District certificates of his insurance protecting workers. Company or companies providing insurance coverage shall be acceptable to the District, if in the form and coverage as set forth in the Contract Documents.
- C. Employer's Liability Insurance.** Contractor shall provide Employer's Liability Insurance, including Occupational Disease, in the amount of at least one million dollars (\$1,000,000.00) per person per accident. Contractor shall provide District with a certificate of Employer's Liability Insurance. Such insurance shall comply with the provisions of the Contract Documents. The policy shall be endorsed, if applicable, to provide a Borrowed Servant/Alternate Employer Endorsement and contain a Waiver of Subrogation in favor of the District.
- D. Commercial General Liability Insurance.** Contractor shall provide "occurrence" form Commercial General Liability insurance coverage at least as broad as the most current ISO CGL Form 00 01, including but not limited to, premises liability, contractual liability, products/completed operations, personal and advertising injury which may arise from or out of Contractor's operations, use, and management of the Site, or the performance of its obligations hereunder. The policy shall not contain any exclusion contrary to this Contract including but not limited to endorsements or provisions limiting coverage for (1) contractual liability (including but not limited to ISO CG 24 26 or 21 39); or (2) cross-liability for claims or suits against one insured against another. Policy limits shall not be less than \$1,000,000 per occurrence for bodily injury, personal injury and property damage. If Commercial General Liability Insurance or other form with a general aggregate limit is used, either the general aggregate limit shall apply separately to this project/location or the general aggregate limit shall be twice the required occurrence limit. Defense costs shall be paid in addition to the limits.
1. Such policy shall comply with all the requirements of this Article. The limits set forth herein shall apply separately to each insured against whom claims are made or suits are brought, except with respect to the limits of liability.

GENERAL CONDITIONS
SECTION F- LABOR AND CONSTRUCTION

Further the limits set forth herein shall not be construed to relieve the Contractor from liability in excess of such coverage, nor shall it limit Contractor's indemnification obligations to the District, and shall not preclude the District from taking such other actions available to the District under other provisions of the Contract Documents or law.

2. All general liability policies provided pursuant to the provisions of this Article shall comply with the provisions of the Contract Documents.
 3. All general liability policies shall be written to apply to all bodily injury, including death, property damage, personal injury, owned and non-owned equipment, blanket contractual liability, completed operations liability, explosion, collapse, under-ground excavation, removal of lateral support, and other covered loss, however occasioned, occurring during the policy term, and shall specifically insure the performance by Contractor of that part of the indemnification contained in these General Conditions relating to liability for injury to or death of persons and damage to property.
 4. If the coverage contains one or more aggregate limits, a minimum of 50% of any such aggregate limit must remain available at all times; if over 50% of any aggregate limit has been paid or reserved, the District may require additional coverage to be purchased by Contractor to restore the required limits. Contractor may combine primary, umbrella, and as broad as possible excess liability coverage to achieve the total limits indicated above. Any umbrella or excess liability policy shall include the additional insured endorsement described in the Contract Documents.
 5. All policies of general liability insurance shall permit and Contractor does hereby waive any right of subrogation which any insurer of Contractor may acquire from Contractor by virtue of the payment of any loss.
- E. **Automobile Liability Insurance.** Contractor shall provide "occurrence" form Automobile Liability Insurance at least as broad as ISO CA 00 01 (Any Auto) in the amount of, at least, one million dollars (\$1,000,000) per accident for bodily injury and property damage. Such insurance shall provide coverage with respect to the ownership, operation, maintenance, use, loading or unloading of any auto owned, leased, hired or borrowed by Contractor or for which Contractor is responsible, in a form and with insurance companies acceptable to the District. All policies of automobile insurance shall permit and Contractor does hereby waive any right of subrogation which any insurer of Contractor may acquire from Contractor by virtue of the payment of any loss.
1. **Builder's Risk ["All Risk"]** It is the Contractor's responsibility to maintain or cause to be maintained Builder's Risk ["All Risk"] extended coverage insurance on all work, material, equipment, appliances, tools, and structures that are or will become part of the Work and subject to loss or damage by fire, and vandalism and malicious mischief, in an amount to cover 100% of the replacement cost. The District accepts no responsibility for the Work until the Work is formally accepted by the District. The Contractor shall provide a

GENERAL CONDITIONS
SECTION F- LABOR AND CONSTRUCTION

certificate evidencing this coverage before commencing performance of the Work.

2. The named insureds shall be Contractor, all Subcontractors of any tier (excluding those solely responsible for design work), suppliers, and District, its elected officials, officers, employees, agents and authorized volunteers, as their interests may appear. Contractor shall not be required to maintain property insurance for any portion of the Work following acceptance by District.
3. Policy shall be provided for replacement value on an "all risk" basis. There shall be no coinsurance penalty provision in any such policy. Policy must include: (1) coverage for any ensuing loss from faulty workmanship, nonconforming work, omission or deficiency in design or specifications; (2) coverage against machinery accidents and operational testing; (3) coverage for removal of debris, and insuring the buildings, structures, machinery, equipment, materials, facilities, fixtures and all other properties constituting a part of the Project; (4) transit coverage, including ocean marine coverage (unless insured by the supplier), with sub-limits sufficient to insure the full replacement value of any key equipment item; and (5) coverage with sub-limits sufficient to insure the full replacement value of any property or equipment stored either on or off the Site. Such insurance shall be on a form acceptable to District to ensure adequacy and sublimit.
4. In addition, the policy shall meet the following requirements:
 - a. Insurance policies shall be so conditioned as to cover the performance of any extra work performed under the Contract.
 - b. Coverage shall include all materials stored on site and in transit.
 - c. Coverage shall include Contractor's tools and equipment.
 - d. Insurance shall include boiler, machinery and material hoist coverage.
- F. **Contractor's Pollution Liability Coverage.** Contractor shall provide pollution liability insurance in an amount not less than \$1,000,000 per occurrence and \$2,000,000 aggregate.
- G. Contractor shall require all tiers of sub-contractors working under this Contract to provide the insurance required under this Article unless otherwise agreed to in writing by District. Contractor shall make certain that any and all subcontractors hired by Contractor are insured in accordance with this Contract. If any subcontractor's coverage does not comply with the foregoing provisions, Contractor shall indemnify and hold the District harmless from any damage, loss, cost, or expense, including attorneys' fees, incurred by the District as a result thereof.

GENERAL CONDITIONS
SECTION F- LABOR AND CONSTRUCTION

ARTICLE 39 FORM AND PROOF OF CARRIAGE OF INSURANCE

- A. Any insurance carrier providing insurance coverage required by the Contract Documents shall be admitted to and authorized to do business in the State of California unless waived, in writing, by the District's Risk Manager. Carrier(s) shall have an A.M. Best rating of not less than an A:VII. Insurance deductibles or self-insured retentions must be declared by the Contractor. At the election of the District the Contractor shall either 1) reduce or eliminate such deductibles or self-insured retentions, or 2) procure a bond which guarantees payment of losses and related investigations, claims administration, and defense costs and expenses. If umbrella or excess liability coverage is used to meet any required limit(s) specified herein, the Contractor shall provide a "follow form" endorsement satisfactory to the District indicating that such coverage is subject to the same terms and conditions as the underlying liability policy.
- B. Each insurance policy required by this Contract shall be endorsed to state that: (1) coverage shall not be suspended, voided, reduced or cancelled except after thirty (30) days prior written notice by certified mail, return receipt requested, has been given to the District; and (2) any failure to comply with reporting or other provisions of the policies, including breaches of warranties, shall not affect coverage provided to the District, its officials, officers, agents, employees, and volunteers.
- C. The Certificate(s) and policies of insurance shall contain or shall be endorsed to contain the covenant of the insurance carrier(s) that it shall provide no less than thirty (30) days written notice be given to the District prior to any material modification or cancellation of such insurance. In the event of a material modification or cancellation of coverage, the District may terminate the Contract or stop the Work in accordance with the Contract Documents, unless the District receives, prior to such effective date, another properly executed original Certificate of Insurance and original copies of endorsements or certified original policies, including all endorsements and attachments thereto evidencing coverage's set forth herein and the insurance required herein is in full force and effect. Contractor shall not take possession, or use the Site, or commence operations under this Contract until the District has been furnished original Certificate(s) of Insurance and certified original copies of endorsements or policies of insurance including all endorsements and any and all other attachments as required in this Article. The original endorsements for each policy and the Certificate of Insurance shall be signed by an individual authorized by the insurance carrier to do so on its behalf.
- D. The Certificate(s) of Insurance, policies and endorsements shall so covenant and shall be construed as primary, and the District's insurance and/or deductibles and/or self-insured retentions or self-insured programs shall not be construed as contributory.
- E. District reserves the right to adjust the monetary limits of insurance coverages during the term of this Contract including any extension thereof if, in the District's reasonable judgment, the amount or type of insurance carried by the Contractor becomes inadequate.

GENERAL CONDITIONS
SECTION F- LABOR AND CONSTRUCTION

- F. Contractor shall report to the District, in addition to the Contractor's insurer, any and all insurance claims submitted by the Contractor in connection with the Work under this Contract.

ARTICLE 40 TIME FOR COMPLETION AND LIQUIDATED DAMAGES

- A. **Time for Completion/Liquidated Damages.** Time is of the essence in the completion of the Work. Work shall be commenced within ten (10) Days of the date stated in the District's Notice to Proceed and shall be completed by Contractor in the time specified in the Contract Documents. The District is under no obligation to consider early completion of the Project; and the Contract completion date shall not be amended by the District's receipt or acceptance of the Contractor's proposed earlier completion date. Furthermore, Contractor shall not, under any circumstances, receive additional compensation from the District (including but not limited to indirect, general, administrative or other forms of overhead costs) for the period between the time of earlier completion proposed by the Contractor and the Contract completion date. If the Work is not completed as stated in the Contract Documents, it is understood that the District will suffer damage. In accordance with Government Code section 53069.85, being impractical and infeasible to determine the amount of actual damage, it is agreed that Contractor shall pay to the District as fixed and liquidated damages, and not as a penalty, the sum stipulated in the Contract for each calendar day of delay until the Work is fully completed. Contractor and its surety shall be liable for any liquidated damages. Any money due or to become due the Contractor may be retained to cover liquidated damages.
- B. **Inclement Weather.** Contractor shall abide by the Engineer's determination of what constitutes inclement weather. Time extensions for inclement weather shall only be granted when the Work stopped during inclement weather is on the critical path of the Project schedule.
- C. **Extension of Time.** Contractor shall not be charged liquidated damages because of any delays in completion of the Work due to unforeseeable causes beyond the control and without the fault or negligence of Contractor (or its subcontractors or suppliers). Contractor shall within five (5) Days of identifying any such delay notify the District in writing of causes of delay. The District shall ascertain the facts and extent of delay and grant extension of time for completing the Work when, in its judgment, the facts justify such an extension. Time extensions to the Project shall be requested by the Contractor as they occur and without delay. No delay claims shall be permitted unless the event or occurrence delays the completion of the Project beyond the Contract completion date.
- D. **No Damages for Reasonable Delay.** The District's liability to Contractor for delays for which the District is responsible shall be limited to only an extension of time unless such delays were unreasonable under the circumstances. In no case shall the District be liable for any costs which are borne by the Contractor in the regular course of business, including, but not limited to, home office overhead and other ongoing costs. Damages caused by unreasonable District delay, including delays caused by items that are the responsibility of the District

GENERAL CONDITIONS
SECTION F- LABOR AND CONSTRUCTION

pursuant to Government Code section 4215, shall be based on actual costs only, no proportions or formulas shall be used to calculate any delay damages.

ARTICLE 41 COST BREAKDOWN AND INVOICING

Contractor shall furnish on forms Approved by the District:

- A. Within ten (10) Days of Notice to Proceed with the Contract, a detailed estimate giving a complete breakdown of the Contract price, if the Contract amount is a lump sum.
- B. A monthly itemized estimate of Work done for the purpose of making progress payments. In order for the District to consider and evaluate each progress payment application, the Contractor shall submit a detailed measurement of Work performed and a progress estimate of the value thereof before the tenth (10th) Day of the following month.
- C. Contractor shall submit, with each of its payment requests, an adjusted list of actual quantities, verified by the Engineer, for unit price items listed, if any, in the Bid Form.
- D. Following the District's Acceptance of the Work, the Contractor shall submit to the District a written statement of the final quantities of unit price items for inclusion in the final payment request.
- E. The District shall have the right to adjust any estimate of quantity and to subsequently correct any error made in any estimate for payment.

Contractor shall certify under penalty of perjury, that all cost breakdowns and periodic estimates accurately reflect the Work on the Project.

ARTICLE 42 PROGRESS ESTIMATES AND PAYMENT

- A. By the tenth (10th) Day of the following calendar month, Contractor shall submit to Engineer a payment request which shall set forth in detail the value of the Work done for the period beginning with the date work was first commenced and ending on the end of the calendar month for which the payment request is prepared. Contractor shall include any amount earned for authorized extra work. From the total thus computed, a deduction shall be made in the amount of five percent (5%) for retention, except where the District has adopted a finding that the Work done under the Contract is substantially complex, and then the amount withheld as retention shall be the percentage specified in the Notice Inviting Bids. From the remainder a further deduction may be made in accordance with Section B below. The amount computed, less the amount withheld for retention and any amounts withheld as set forth below, shall be the amount of the Contractor's payment request.
- B. The District may withhold a sufficient amount or amounts of any payment or payments otherwise due to Contractor, as in his judgment may be necessary to cover:

GENERAL CONDITIONS
SECTION F- LABOR AND CONSTRUCTION

1. Payments which may be past due and payable for just claims against Contractor or any subcontractors for labor or materials furnished in and about the performance of work on the Project under this Contract.
 2. Defective work not remedied.
 3. Failure of Contractor to make proper payments to his subcontractor or for material or labor.
 4. Completion of the Contract if there is a reasonable doubt that the Work can be completed for balance then unpaid.
 5. Damage to another contractor or a third party.
 6. Amounts which may be due the District for claims against Contractor.
 7. Failure of Contractor to keep the record ("as-built") drawings up to date.
 8. Failure to provide update on construction schedule as required herein.
 9. Site cleanup.
 10. Failure to comply with Contract Documents.
 11. Liquidated damages.
 12. Legally permitted penalties.
- C. The District may apply such withheld amount or amounts to payment of such claims or obligations at its discretion with the exception of subsections (B)(1), (3), and (5) of this Article, which must be retained or applied in accordance with applicable law. In so doing, the District shall be deemed the agent of Contractor and any payment so made by the District shall be considered as a payment made under contract by the District to Contractor and the District shall not be liable to Contractor for such payments made in good faith. Such payments may be made without prior judicial determination of claim or obligations. The District will render Contractor a proper accounting of such funds disbursed on behalf of Contractor.
- D. Upon receipt, the Engineer shall review the payment request to determine whether it is undisputed and suitable for payment. If the payment request is determined to be unsuitable for payment, it shall be returned to Contractor as soon as practicable but not later than seven (7) Days after receipt, accompanied by a document setting forth in writing the reasons why the payment request is not proper. The District shall make the progress payment within 30 calendar days after the receipt of an undisputed and properly submitted payment request from Contractor, provided that a release of liens and claims has been received from the Contractor pursuant to Civil Code section 8132. The number of days available to the District to make a payment without incurring interest pursuant to

GENERAL CONDITIONS
SECTION F- LABOR AND CONSTRUCTION

this paragraph shall be reduced by the number of days by which the Engineer exceeds the seven (7) Day requirement.

- E. A payment request shall be considered properly executed if funds are available for payment of the payment request and payment is not delayed due to an audit inquiry by the financial officer of the District.

ARTICLE 43 SECURITIES FOR MONEY WITHHELD

Pursuant to section 22300 of the Public Contract Code of the State of California, Contractor may request the District to make retention payments directly to an escrow agent or may substitute securities for any money withheld by the District to ensure performance under the contract. At the request and expense of Contractor, securities equivalent to the amount withheld shall be deposited with the District or with a state or federally chartered bank as the escrow agent who shall return such securities to Contractor upon satisfactory completion of the contract. Deposit of securities with an escrow agent shall be subject to a written agreement substantially in the form provided in section 22300 of the Public Contract Code.

ARTICLE 44 CHANGES AND EXTRA WORK.

A. Contract Change Orders.

1. The District, without invalidating the Contract, may order changes in the Work consisting of additions, deletions or other revisions, and the Contract Price and Contract Time shall be adjusted accordingly. Except as otherwise provided herein, all such changes in the Work shall be authorized by Change Order, and shall be performed under the applicable conditions of the Contract Documents. A Change Order signed by the Contractor indicates the Contractor's agreement therewith, including any adjustment in the Contract Price or the Contract Time, and the full and final settlement of all costs (direct, indirect and overhead) related to the Work authorized by the Change Order.
2. Contractor shall promptly execute changes in the Work as directed in writing by the District even when the parties have not reached agreement on whether the change increases the scope of Work or affects the Contract Price or Contract Time. All claims for additional compensation to the Contractor shall be presented in writing. No claim will be considered after the Work in question has been done unless a written Change Order has been issued or a timely written notice of claim has been made by Contractor.
3. Whenever any change is made as provided for herein, such change shall be considered and treated as though originally included in the Contract, and shall be subject to all terms, conditions, and provisions of the original Contract.
4. Contractor shall not be entitled to claim or bring suit for damages, whether for loss of profits or otherwise, on account of any decrease or omission of any item or portion of Work to be done.

GENERAL CONDITIONS
SECTION F- LABOR AND CONSTRUCTION

5. No dispute, disagreement, or failure of the parties to reach agreement on the terms of the Change Order shall relieve the Contractor from the obligation to proceed with performance of the work, including Additional Work, promptly and expeditiously.
6. Contractor shall make available to the District any of the Contractor's documents related to the Project immediately upon request of the District, as set forth in Article 52.
7. Any alterations, extensions of time, Additional Work, or any other changes may be made without securing consent of the Contractor's surety or sureties.

B. Contract Price Change.

1. Process for Determining Adjustments in Contract Price.
 - a. Owner Initiated Change. The Contractor must submit a complete cost proposal, including any change in the Contract Price or Contract Time, within seven (7) Days after receipt of a scope of a proposed change order initiated by the District, unless the District requests that proposals be submitted in less than seven (7) Days.
 - b. Contractor Initiated Change. The Contractor must give written notice of a proposed change order required for compliance with the Contract Documents within seven (7) Days of discovery of the facts giving rise to the proposed change order.
 - c. Whenever possible, any changes to the Contract amount shall be in a lump sum mutually agreed to by the Contractor and the District.
 - d. Price quotations from the Contractor shall be accompanied by sufficiently detailed supporting documentation to permit verification by the District, including but not limited to estimates and quotations from subcontractors or material suppliers, as the District may reasonably request. Contractor shall certify the accuracy of all Change Order Requests under penalty of perjury.
 - e. If the Contractor fails to submit a complete cost proposal within the seven (7) Day period (or as requested), the District has the right to order the Contractor in writing to commence the Work immediately on a time and materials basis and/or issue a lump sum change to the Contract Price and/or Contract Time in accordance with the District's estimate. If the change is issued based on the District's estimate, the Contractor will waive its right to dispute the action unless within fifteen (15) Days following completion of the added/deleted work, the Contractor presents written proof that the District's estimate was in error.
2. Unit Price Change Orders.
 - a. When the actual quantity of a Unit Price item varies from the Bid Form, compensation for the change in quantity will be calculated by multiplying the

GENERAL CONDITIONS
SECTION F- LABOR AND CONSTRUCTION

actual quantity by the Unit Price. This calculation may result in either an additive or deductive Final Change Order pursuant to the Contract Documents.

- b. No Mark up for Overhead and Profit. Because the Contract Unit Prices provided in the Bid Form include Overhead and Profit as determined by Contractor at the time of Bid submission, no mark up or deduction for Overhead and Profit will be included in Unit Price Change Orders.
 - c. Bid items included on the Bid Form may be deducted from the Work in their entirety without any negotiated extra costs.
 - d. Contractor acknowledges that unit quantities are estimates and agrees that the estimated unit quantities listed on the Bid Form will be adjusted to reflect the actual unit quantities which may result in an adjustment to the Contract Unit Prices. Such an adjustment will be made by execution of a final additive or deductive Change Order following Contractor's completion of the Work. Upon notification, Contractor's failure to respond within seven (7) Days will result in District's issuance of a unit quantity adjustment to the Contract Unit Prices and/or Contract Time in accordance with the Contract Documents.
 - e. The District or Contractor may make a Claim for an adjustment in the Unit Price in accordance with the Contract Documents if:
 - i. the quantity of any item of Unit Price Work performed by Contractor differs by twenty-five percent (25%) or more from the estimated quantity of such item indicated in the Contract; and
 - ii. there is no corresponding adjustment with respect to any other item of Work; and
 - iii. Contractor believes that Contractor is entitled to an increase in Unit Price as a result of having incurred additional expense or the District believes that the District is entitled to a decrease in Unit Price and the parties are unable to agree as to the amount of any such increase or decrease..
3. Lump Sum Change Orders. Compensation for Lump Sum Change Orders shall be limited to expenditures necessitated specifically by the Additional Work, and shall be segregated as follows:
- a. Labor. The costs of labor will be the actual cost for wages prevailing locally for each craft or type of worker at the time the Additional Work is done, plus employer payments of payroll taxes and insurance, health and welfare, pension, vacation, apprenticeship funds, and other direct costs resulting from Federal, State or local laws, as well as assessment or benefits required by lawful collective bargaining agreements. The use of a labor classification which would increase the Additional Work cost will not be permitted unless the Contractor establishes the necessity for such new classifications. Labor costs for equipment operators and helpers shall be reported only when such costs are not included in the invoice for equipment rental.

GENERAL CONDITIONS
SECTION F- LABOR AND CONSTRUCTION

- b. Materials. The cost of materials reported shall be at invoice or lowest current price at which such materials are locally available in the quantities involved, plus sales tax, freight, and delivery. Materials costs shall be based upon supplier or manufacturer's invoice. If invoices or other satisfactory evidence of cost are not furnished within fifteen (15) Days of delivery, then the District shall determine the materials cost, at its sole discretion.
 - c. Tool and Equipment Use. Costs for the use of small tools, which are tools that have a replacement value of \$1,000 or less, shall be considered included in the Overhead and Profit mark-ups established below. Regardless of ownership, the rates to be used in determining equipment use costs shall not exceed listed rates prevailing locally at equipment rental agencies, or distributors, at the time the Work is performed.
4. Time and Materials Change Orders.
- a. General. The term Time and Materials means the sum of all costs reasonably and necessarily incurred and paid by Contractor for labor, materials, and equipment in the proper performance of Additional Work. Except as otherwise may be agreed to in writing by the District, such costs shall be in amounts no higher than those prevailing in the locality of the Project, and shall include only the following items.
 - b. Timely and Final Documentation.
 - i. T&M Daily Sheets. Contractor must submit timesheets, materials invoices, records of equipment hours, and records of rental equipment hours to the District's Representative for an approval signature **each day** Additional Work is performed. Failure to get the District's Representative's approval signature each Day shall result in a waiver of Contractor's right to claim these costs. The District's Representative's signature on time sheets only serves as verification that the Work was performed and is not indicative of District's agreement to Contractor's entitlement to the cost.
 - ii. T&M Daily Summary Sheets. All documentation of incurred costs ("T&M Daily Summary Sheets") shall be submitted by Contractor within **three (3) Days** of incurring the cost for labor, material, equipment, and special services as Additional Work is performed. Contractor's actual costs shall be presented in a summary table in an electronic spreadsheet file by labor, material, equipment, and special services. Each T&M Daily Summary Sheet shall include Contractor's actual costs incurred for the Additional Work performed that day and a cumulative total of Contractor's actual costs incurred for the Additional Work. Contractor's failure to provide a T&M Daily Summary Sheet showing a total cost summary within three (3) Days but within five (5) Days of performance of the Work will result in the Contractor's otherwise allowable overhead and profit being reduced by 50% for that portion of Additional Work which was not documented in a timely manner. Contractor's failure to submit the T&M Daily Summary Sheet

GENERAL CONDITIONS
SECTION F- LABOR AND CONSTRUCTION

within five (5) Days of performance of the Work will result in a total waiver of Contractor's right to claim these costs.

- iii. T&M Total Cost Summary Sheet. Contractor shall submit a T&M Total Cost Summary Sheet, which shall include total actual costs, within **seven (7) Days** following completion of District approved Additional Work. Contractor's total actual cost shall be presented in a summary table in an electronic spreadsheet file by labor, material, equipment, and special services. Contractor's failure to submit the T&M Total Cost Summary Sheet within seven (7) Days of completion of the Additional Work will result in Contractor's waiver for any reimbursement of any costs associated with the T&M Summary Sheets or the performance of the Additional Work.
 - iv. Labor. The Contractor will be paid the cost of labor for the workers used in the actual and direct performance of the Work. The cost of labor will be the sum of the actual wages paid (which shall include any employer payments to or on behalf of the workers for health and welfare, pension, vacation, and similar purposes) substantiated by timesheets and certified payroll for wages prevailing for each craft or type of workers performing the Additional Work at the time the Additional Work is done, and the labor surcharge set forth in the Department of Transportation publication entitled *Labor Surcharge and Equipment Rental Rates*, which is in effect on the date upon which the Work is accomplished and which is a part of the Contract. The labor surcharge shall constitute full compensation for all payments imposed by Federal, State, or local laws and for all other payments made to, or on behalf of, the workers, other than actual wages.
 - v. Equipment Operator Exception. Labor costs for equipment operators and helpers shall be paid only when such costs are not included in the invoice for equipment rental.
 - vi. Foreman Exception. The labor costs for foremen shall be proportioned to all of their assigned work and only that applicable to the Additional Work shall be paid. Indirect labor costs, including, without limitation, the superintendent, project manager, and other labor identified in the Contract Documents will be considered Overhead.
- C. Materials. The cost of materials reported shall be itemized at invoice or lowest current price at which materials are locally available and delivered to the Project site in the quantities involved, plus the cost of sales tax, freight, delivery, and storage.
- 1. Trade discounts available to the purchaser shall be credited to the District notwithstanding the fact that such discounts may not have been taken by Contractor.

GENERAL CONDITIONS
SECTION F- LABOR AND CONSTRUCTION

2. For materials secured by other than a direct purchase and direct billing to the purchaser, the cost shall be deemed to be the price paid to the actual supplier as determined by the District's Representative.
3. Payment for materials from sources owned wholly or in part by the purchaser shall not exceed the price paid by the purchaser for similar materials from said sources on Additional Work items or the current wholesale price for such materials delivered to the Project site, whichever price is lower.
4. If, in the opinion of the District's Representative, the cost of materials is excessive, or Contractor does not furnish satisfactory evidence of the cost of such materials, then the cost shall be deemed to be the lowest current wholesale price for the total quantity concerned delivered to the Project site less trade discounts.
5. The District reserves the right to furnish materials for the Additional Work and no Claim shall be allowed by Contractor for costs of such materials or Indirect Costs or profit on District furnished materials.

D. Equipment.

1. Rental Time. The rental time to be paid for equipment on the Project site shall be the time the equipment is in productive operation on the Additional Work being performed and, in addition, shall include the time required to move the equipment to the location of the Additional Work and return it to the original location or to another location requiring no more time than that required to return it to its original location; except that moving time will not be paid if the equipment is used on other than the Additional Work, even though located at the site of the Additional Work.
 - (a) Rental Time Not Allowed. Rental time will not be allowed while equipment is inoperative due to breakdowns.
 - (b) Computation Method. The following shall be used in computing the rental time of equipment on the Project site.
 - (i) When hourly rates are paid, any part of an hour less than 30 minutes of operation shall be considered to be 1/2-hour of operation, and any part of an hour in excess of 30 minutes will be considered one hour of operation.
 - (ii) When daily rates are paid, any part of a day less than 4 hours operation shall be considered to be 1/2-day of operation, and any part of an hour in excess of 4 hours will be considered one day of operation.
2. Rental Rates. Contractor will be paid for the use of equipment at the lesser of (i) the actual rental rate, or (ii) the rental rate listed for that equipment in the California Department of Transportation publication

GENERAL CONDITIONS
SECTION F- LABOR AND CONSTRUCTION

entitled *Labor Surcharge and Equipment Rental Rates*, which is in effect on the date upon which the Contract was executed. Such rental rates will be used to compute payments for equipment whether the equipment is under Contractor's control through direct ownership, leasing, renting, or another method of acquisition. The rental rate to be applied for use of each item of equipment shall be the rate (i.e., daily, monthly) resulting in the least total cost to the District for the total period of use. If it is deemed necessary by Contractor to use equipment not listed in the publication, an equitable rental rate for the equipment will be established by the District's Representative. Contractor may furnish cost data which might assist the District's Representative in the establishment of the rental rate.

E. Contractor-Owned Equipment.

1. For Contractor-owned equipment, the allowed equipment rental rate will be limited to the monthly equipment rental rate using a utilization rate of 173 hours per month.
2. (b) For Contractor-owned equipment, the rental time to be paid for equipment on the Site shall be the time the equipment is in productive operation, unless, in the instance of standby time, the equipment could be actively used by Contractor on another project, then District shall pay for the entirety of the time the equipment is on Site. It shall be Contractor's burden to demonstrate to the District that the equipment could be actively used on another project.
 - a. All equipment shall, in the opinion of the District's Representative, be in good working condition and suitable for the purpose for which the equipment is to be used.
 - b. Before construction equipment is used on the Additional Work, Contractor shall plainly stencil or stamp an identifying number thereon at a conspicuous location, and shall furnish to the District's Representative, in duplicate, a description of the equipment and its identifying number and the scheduled Additional Work activities planned.
 - c. Unless otherwise specified, manufacturer's rating and manufacturer approved modifications shall be used to classify equipment for the determination of applicable rental rates. Equipment which has no direct power unit shall be powered by a unit of at least the minimum rating recommended by the manufacturer.

- F. Special Services. Special work or services are defined as that Additional Work characterized by extraordinary complexity, sophistication, or innovation or a combination of the foregoing attributes which are unique to the construction industry.

GENERAL CONDITIONS
SECTION F- LABOR AND CONSTRUCTION

- G. Invoices for Special Services. When the District's Representative and Contractor determine that a special service is required which cannot be performed by the forces of Contractor or those of any of its Subcontractors, the special service may be performed by an entity especially skilled in the Additional Work. Invoices for special services based upon the current fair market value thereof may be accepted without complete itemization of labor, material, and equipment rental costs, after validation of market values by the District's Representative.
- H. Discount and Allowance. All invoices for special services will be adjusted by deducting all trade discounts offered or available, whether the discounts were taken or not. In lieu of Overhead and Profit specified herein, a total allowance not to exceed fifteen percent (15%) for Overhead and Profit will be added to invoices for Special Services.
- a. When the District determines, in its sole discretion, that competitive bidding is necessary for certain special services, Contractor shall solicit competitive bids for those special services.
- I. Excluded Costs. The term Time and Material shall not include any of the following costs or any other home or field office overhead costs, all of which are to be considered administrative costs covered by Contractor's allowance for Overhead and Profit.
1. Overhead Cost. Payroll costs and other compensation of Contractor's officers, executives, principals, general managers, engineers, architects, estimators, attorneys, auditors, accountants, purchasing and contracting agents, timekeepers, clerks, and other personnel employed by Contractor whether at the Site or in Contractor's principal office or any branch office, material yard, or shop for general administration of the Additional Work;
 2. Office Expenses. Expenses of Contractor's principal and branch offices;
 3. Capital Expenses. Any part of Contractor's capital expenses, including interest on Contractor's capital employed for the Additional Work and charges against Contractor for delinquent payments;
 4. Negligence. Costs due to the negligence of Contractor or any Subcontractor or Supplier, or anyone directly or indirectly employed by any of them or for whose acts any of them may be liable, including without limitation the correction of Defective Work, disposal of materials or equipment wrongly supplied, and making good any damage to property;
 5. Other. Other overhead or general expense costs of any kind and the cost of any item not specifically and expressly included in the Contract Documents;

GENERAL CONDITIONS
SECTION F- LABOR AND CONSTRUCTION

6. Small Tools. Cost of small tools valued at less than \$1,000 and that remain the property of Contractor;
 7. Administrative Costs. Costs associated with the preparation of Change Orders (whether or not ultimately authorized), cost estimates, or the preparation or filing of Claims;
 8. Anticipated Lost Profits. Expenses of Contractor associated with anticipated lost profits or lost revenues, lost income or earnings, lost interest on earnings, or unpaid retention;
 9. Home Office Overhead. Costs derived from the computation of a "home office overhead" rate by application of the *Eichleay, Allegheny*, burden fluctuation, or other similar methods;
 10. Special Consultants and Attorneys. Costs of special consultants or attorneys, whether or not in the direct employ of Contractor, employed for services specifically related to the resolution of a Claim, dispute, or other matter arising out of or relating to the performance of the Additional Work.
- J. Overhead, Profit and Other Charges. The mark-up for overhead (including supervision) and profit on work added to the Contract shall be according to the following:
1. "Net Cost" is defined as consisting of costs of labor, materials, and tools and equipment only excluding overhead and profit. The costs of applicable insurance and bond premium will be reimbursed to the Contractor and subcontractors at cost only, without mark-up. Contractor shall provide District with documentation of the costs, including, but not limited to, payroll records, invoices, and such other information as District may reasonably request.
 2. For Work performed by the Contractor's forces, the added cost for overhead and profit shall not exceed fifteen percent (15%) of the Net Cost of the Work.
 3. For Work performed by a subcontractor, the added cost for overhead and profit shall not exceed fifteen percent (15%) of the subcontractor's Net Cost of the Work to which the Contractor may add five percent (5%) of the subcontractor's Net Cost.
 4. For Work performed by a sub-subcontractor, the added cost for overhead and profit shall not exceed fifteen percent (15%) of the sub-subcontractor's Net Cost for Work to which the subcontractor and general contractor may each add an additional five percent (5%) of the Net Cost of the lower tier subcontractor.
 5. No additional mark-up will be allowed for lower tier subcontractors, and in no case shall the added cost for overhead and profit payable

GENERAL CONDITIONS
SECTION F- LABOR AND CONSTRUCTION

by District exceed twenty-five percent (25%) of the Net Cost as defined herein, of the party that performs the Work.

6. All of the following costs are included in the markups for overhead and profit described above, and Contractor shall not receive any additional compensation for: Submittals, drawings, field drawings, Shop Drawings, including submissions of drawings; field inspection; General Superintendence; General administration and preparation of cost proposals, schedule analysis, Change Orders, and other supporting documentation; computer services; reproduction services; Salaries of project engineer, superintendent, timekeeper, storekeeper, and secretaries; Janitorial services; Small tools, incidentals and consumables; Temporary On-Site facilities (Offices, Telephones, High Speed Internet Access, Plumbing, Electrical Power, Lighting; Platforms, Fencing, Water), Jobsite and Home office overhead or other expenses; vehicles and fuel used for work otherwise included in the Contract Documents; Surveying; Estimating; Protection of Work; Handling and disposal fees; Final Cleanup; Other Incidental Work; Related Warranties; insurance and bond premiums.
7. For added or deducted Work by subcontractors, the Contractor shall furnish to the District the subcontractor's signed detailed record of the cost of labor, material and equipment, including the subcontractor markup for overhead and profit. The same requirement shall apply to sub-subcontractors
8. For added or deducted work furnished by a vendor or supplier, the Contractor shall furnish to the District a detailed record of the cost to the Contractor, signed by such vendor or supplier.
9. Any change in the Work involving both additions and deletions shall indicate a net total cost, including subcontracts and materials. Allowance for overhead and profit, as specified herein, shall be applied if the net total cost is an increase in the Contract Price; overhead and profit allowances shall not be applied if the net total cost is a deduction to the Contract Price. The estimated cost of deductions shall be based on labor and material prices on the date the Contract was executed.
10. Contractor shall not reserve a right to assert impact costs, extended job site costs, extended overhead, constructive acceleration and/or actual acceleration beyond what is stated in the Change Order for Work. No claims shall be allowed for impact, extended overhead costs, constructive acceleration and/or actual acceleration due to a multiplicity of changes and/or clarifications. The Contractor may not change or modify the District's change order form in an attempt to reserve additional rights.
11. If the District disagrees with the proposal submitted by Contractor, it will notify the Contractor and the District will provide its opinion of the

GENERAL CONDITIONS
SECTION F- LABOR AND CONSTRUCTION

appropriate price and/or time extension. If the Contractor agrees with the District, a Change Order will be issued by the District. If no agreement can be reached, the District shall have the right to issue a unilateral Change Order setting forth its determination of the reasonable additions or savings in costs and time attributable to the extra or deleted work. Such determination shall become final and binding if the Contractor fails to submit a claim in writing to the District within fifteen (15) Days of the issuance of the unilateral Change Order, disputing the terms of the unilateral Change Order, and providing such supporting documentation for its position as the District may require.

K. Change of Contract Times.

1. The Contract Times may only be changed by a Change Order.
2. All changes in the Contract Price and/or adjustments to the Contract Times related to each change shall be included in Contractor's COR pursuant to this Article. No cost or time will be allowed for cumulative effects of multiple changes. All Change Orders must state that the Contract Time is not changed or is either increased or decreased by a specific number of days. Failure to include a change to time shall waive any change to the time unless the parties mutually agree in writing to postpone a determination of the change to time resulting from the Change Order.
3. Notice of the amount of the request for adjustment in the Contract Times with supporting data shall be delivered within seven (7) Days after such start of occurrence, unless District's Representative allows an additional period of time to ascertain more accurate data in support of the request. No extension of time or additional compensation shall be given for a delay if the Contractor failed to give notice in the manner and within the time prescribed.
4. District may elect, at District's sole discretion, to grant an extension in Contract Times, without Contractor's request, because of delays or other factors.

L. Use of Float and Critical Path.

1. Float is for the benefit of the Project. Float shall not be considered for the exclusive use or benefit of either the District or the Contractor.
2. Contractor shall not be entitled to compensation, and District will not compensate Contractor, for delays which impact early completion. Any difference in time between the Contractor's early completion and the Contract Time shall be considered a part of the Project float.
3. Contractor's entitlement to an extension of the Contract Times is limited to a District-caused extension of the critical path, reduced by the Contractor's concurrent delays, and established by a proper time impact analysis. No time extension shall be allowed unless, and then only to the extent that, the District-caused delay extends the critical path beyond the

GENERAL CONDITIONS
SECTION F- LABOR AND CONSTRUCTION

previously approved Contract Time. If approved, the increase in time required to complete the Work shall be added to the Contract Time.

4. Contractor shall not be entitled to an adjustment in the Contract Price or Contract Times for delays within the control of Contractor. Delays attributable to and within the control of a Subcontractor or Supplier shall be deemed to be delays within the control of Contractor.
5. If Contractor is delayed in the performance or progress of the Work by fire, flood, epidemic, abnormal weather conditions (as determined by the District), Acts of God, acts or failures to act of utility owners not under the control of District, or other causes not the fault of and beyond control of District and Contractor, then Contractor shall be entitled to a time extension when the Work stopped is on the critical path. Such a non-compensable adjustment shall be Contractor's sole and exclusive remedy for such delays. Contractor must submit a timely request in accordance with the requirements of this Article.

M. Utility-Related Delays.

1. Contractor shall immediately notify in writing the utility owner and District's Representative of its construction schedule and any subsequent changes in the construction schedule which will affect the time available for protection, removal, or relocation of utilities. Requests for extensions of time arising out of utility relocation or repair delays shall be filed in accordance with this Article.
2. Contractor shall not be entitled to damages or additional payment for delays attributable to utility relocations or alterations if correctly located, as noted in the Contract Documents or by the Underground Service Alert survey.

N. Content for Requests for Contract Extension. Contractor's justification for entitlement shall be clear and complete citing specific Contract Document references and reasons on which Contractor's entitlement is based. At a minimum, each request for a time extension must include:

1. Each request for an extension of Contract Time must identify the impacting event, in narrative form, providing a description of the delay event and sufficient justification as to why the Contractor is entitled to a time extension. Contractor must demonstrate that the delay arises from unforeseeable causes beyond the control and without the fault or negligence of both Contractor and any Subcontractors or Suppliers, or any other persons or organizations employed by any of them or for whose acts any of them may be liable, and that such causes in fact lead to performance or completion of the Work, or specified part in question, beyond the corresponding Contract Times, despite Contractor's reasonable and diligent actions to guard against those effects.

GENERAL CONDITIONS
SECTION F- LABOR AND CONSTRUCTION

2. Each request for an extension of Contract Time must include a time impact analysis in CPM format, using the Contemporaneous Impacted As-Planned Schedule Analysis to calculate the impact of the delay event.

O. No Damages for Reasonable Delay.

1. District's liability to Contractor for delays for which District is responsible shall be limited to only an extension of time unless such delays were unreasonable under the circumstances. In no case shall District be liable for any costs which are borne by the Contractor in the regular course of business, including, but not limited to, home office overhead and other ongoing costs.
2. Damages caused by unreasonable District delay that impact the critical path, including delays caused by items that are the responsibility of the District pursuant to Government Code section 4215, shall be compensated at the Daily Rate established in the Special Conditions. No other calculations, proportions or formulas shall be used to calculate any delay damages.
3. District and District's Representative, and the officers, members, partners, employees, agents, consultants, or subcontractors of each of them, shall not be liable to Contractor for any claims, costs, losses, or damages (including but not limited to all fees and charges of engineers, architects, attorneys, and other professionals and all court or arbitration or other dispute resolution costs) sustained by Contractor on or in connection with any other project or anticipated project.
4. Contractor's failure, neglect, or refusal to comply with the requirements of the Contract Documents, or any portion thereof, shall bar Contractor's request for extensions of the Contract Times. Such failure, neglect, or refusal prejudices District's and District's Representative's ability to recognize and mitigate delay, and such failure, neglect, or refusal prevent the timely analysis of requests for extensions of Contract Times, and whether such extensions may be warranted. Contractor hereby waives all rights to extensions of Contract Times due to delays or accelerations that result from or occur during periods of time for which Contractor fails, neglects, or refuses to fully comply with the requirements of this Article.

ARTICLE 45 FINAL ACCEPTANCE AND PAYMENT

- A. The acceptance of the Work on behalf of the District will be made by the Engineer. Such acceptance by the District shall not constitute a waiver of defects. When the Work has been accepted there shall be paid to Contractor a sum equal to the contract price less any amounts previously paid Contractor and less any amounts withheld by the District from Contractor under the terms of the contract. The final five percent (5%), or the percentage specified in the notice inviting bids where the District has adopted a finding of substantially complete, shall not become due and payable until five (5) calendar days shall have elapsed after the expiration of the period within which all claims may be filed

GENERAL CONDITIONS
SECTION F- LABOR AND CONSTRUCTION

under the provisions of Civil Code section 9356. If the Contractor has placed securities with the District as described herein, the Contractor shall be paid a sum equal to one hundred percent (100%) of the contract price less any amounts due the District under the terms of the Contract.

- B. Unless Contractor advises the District in writing prior to acceptance of the final five percent (5%) or the percentage specified in the notice inviting bids where the District has adopted a finding of substantially complete, or the return of securities held as described herein, said acceptance shall operate as a release to the District of all claims and all liability to Contractor for all things done or furnished in connection with this work and for every act of negligence of the District and for all other claims relating to or arising out of this work. If Contractor advises the District in writing prior to acceptance of final payment or return of the securities that there is a dispute regarding the amount due the Contractor, the District may pay the undisputed amount contingent upon the Contractor furnishing a release of all undisputed claims against the District with the disputed claims in stated amounts being specifically excluded by Contractor from the operation of the release. No payments, however, final or otherwise, shall operate to release Contractor or its sureties from the Faithful Performance Bond, Labor and Material Payment Bond, or from any other obligation under this contract.
- C. In case of suspension of the contract any unpaid balance shall be and become the sole and absolute property of the District to the extent necessary to repay the District any excess in the cost of the Work above the contract price.
- D. Final payment shall be made no later than 60 days after the date of acceptance of the Work by the District or the date of occupation, beneficial use and enjoyment of the Work by the District including any operation only for testing, start-up or commissioning accompanied by cessation of labor on the Work, provided that a release of liens and claims has been received from the Contractor pursuant to Civil Code section 8136. In the event of a dispute between the District and the Contractor, the District may withhold from the final payment an amount not to exceed 150% of the disputed amount.
- E. Within ten (10) calendar days from the time that all or any portion of the retention proceeds are received by Contractor, Contractor shall pay each of its subcontractors from whom retention has been withheld each subcontractor's share of the retention received. However, if a retention payment received by Contractor is specifically designated for a particular subcontractor, payment of the retention shall be made to the designated subcontractor if the payment is consistent with the terms of the subcontract.

ARTICLE 46 OCCUPANCY

The District reserves the right to occupy or utilize any portion of the Work at any time before completion, and such occupancy or use shall not constitute acceptance of any part of Work covered by this Contract. This use shall not relieve the Contractor of its responsibilities under the Contract.

GENERAL CONDITIONS
SECTION F- LABOR AND CONSTRUCTION

ARTICLE 47 INDEMNIFICATION

To the fullest extent permitted by law, Contractor shall immediately defend (with counsel of the District's choosing), indemnify and hold harmless the District, officials, officers, agents, employees, and representatives, and each of them from and against:

- A. Any and all claims, demands, causes of action, costs, expenses, injuries, losses or liabilities, in law or in equity, of every kind or nature whatsoever, but not limited to, injury to or death, including wrongful death, of any person, and damages to or destruction of property of any person, arising out of, related to, or in any manner directly or indirectly connected with the Work or this Contract, including claims made by subcontractors for nonpayment, including without limitation the payment of all consequential damages and attorney's fees and other related costs and expenses, however caused, regardless of whether the allegations are false, fraudulent, or groundless, and regardless of any negligence of the District or its officers, employees, or authorized volunteers (including passive negligence), except the sole negligence or willful misconduct or active negligence of the District or its officials, officers, employees, or authorized volunteers.
- B. Contractor's defense and indemnity obligation herein includes, but is not limited to damages, fines, penalties, attorney's fees and costs arising from claims under the Americans with Disabilities Act (ADA) or other federal or state disability access or discrimination laws arising from Contractor's Work during the course of construction of the improvements or after the Work is complete, as the result of defects or negligence in Contractor's construction of the improvements.
- C. Any and all actions, proceedings, damages, costs, expenses, fines, penalties or liabilities, in law or equity, of every kind or nature whatsoever, arising out of, resulting from, or on account of the violation of any governmental law or regulation, compliance with which is the responsibility of Contractor;
- D. Any and all losses, expenses, damages (including damages to the Work itself), attorney's fees, and other costs, including all costs of defense which any of them may incur with respect to the failure, neglect, or refusal of Contractor to faithfully perform the Work and all of Contractor's obligations under the agreement. Such costs, expenses, and damages shall include all costs, including attorney's fees, incurred by the indemnified parties in any lawsuit to which they are a party.

Contractor shall immediately defend, at Contractor's own cost, expense and risk, with the District Board's choosing, any and all such aforesaid suits, actions or other legal proceedings of every kind that may be brought or instituted against the District, its officials, officers, agents, employees and representatives. Contractor shall pay and satisfy any judgment, award or decree that may be rendered against the District, its officials, officers, employees, agents, employees and representatives, in any such suit, action or other legal proceeding. Contractor shall reimburse the District, its officials, officers, agents, employees and representatives for any and all legal expenses and costs incurred by each of them in connection therewith or in enforcing the indemnity herein provided. The only limitations on this provision shall be those imposed by Civil Code section 2782.

GENERAL CONDITIONS
SECTION F- LABOR AND CONSTRUCTION

ARTICLE 48 PROCEDURE FOR RESOLVING DISPUTES

In accordance with Public Contract Code sections 20104 *et seq.* and other applicable law, public works claims of \$375,000 or less which arise between the Contractor and the District shall be resolved under the following statutory procedure unless the District has elected to resolve the dispute pursuant to Public Contract Code section 10240 *et seq.*

- A. **All Claims.** All claims shall be submitted in writing and accompanied by substantiating documentation. Claims must be filed on or before the date of final payment unless other notice requirements are provided in the contract. "Claim" means a separate demand by the Contractor for (1) a time extension, (2) payment of money or damages arising from work done by or on behalf of the Contractor and payment of which is not otherwise expressly provided for or the Contractor is not otherwise entitled, or (3) an amount the payment of which is disputed by the District.

- B. **Claims Under \$50,000.** The District shall respond in writing to the claim within 45 calendar days of receipt of the claim, or, the District may request, in writing, within 30 calendar days of receipt of the claim, any additional documentation supporting the claim or relating to defenses or claims the District may have. If additional information is needed thereafter, it shall be provided upon mutual agreement of the District and the Contractor. The District's written response shall be submitted 15 calendar days after receiving the additional documentation, or within the same period of time taken by the Contractor to produce the additional information, whichever is greater.

- C. **Claims over \$50,000 but less than or equal to \$375,000.** The District shall respond in writing within 60 calendar days of receipt, or, may request in writing within 30 calendar days of receipt of the claim, any additional documents supporting the claim or relating to defenses or claims the District may have against the District. If additional information is needed thereafter, it shall be provided pursuant to mutual agreement between the District and the Contractor. The District response shall be submitted within 30 calendar days after receipt of the further documents, or within the same period of time taken by the Contractor to produce the additional information or documents, whichever is greater. The Contractor shall make these records and documents available at all reasonable times, without any direct charge.

- D. **All Claims.** The Contractor will submit the claim justification in the following format:
 - 1. Summary of claim merit and price, and Contract clause pursuant to which the claim is made.
 - 2. List of documents relating to claim:
 - a. Specifications
 - b. Drawings
 - c. Clarifications (Requests for Information)
 - d. Schedules

GENERAL CONDITIONS
SECTION F- LABOR AND CONSTRUCTION

e. Other (All Related Documents)

3. Chronology of events and correspondence.
4. Analysis of claim merit.
5. Analysis of claim cost.
6. Analysis of time impact analysis in CPM format.
7. Cover letter and certification of validity of the claim.

E. **All Claims.** If the Contractor disputes the District's response, or if the District fails to respond within the statutory time period(s), the Contractor may so notify the District within 15 calendar days of the receipt of the response or the failure to respond, and demand an informal conference to meet and confer for settlement. Upon such demand, the District shall schedule a meet and confer conference within 30 calendar days.

F. The Contractor must comply with the claims filing procedures set forth in Government Code sections 900 *et seq.* for any claim or any portion thereof that remains in dispute, after the meet and confer conference. For purposes of those provisions, the time within which a claim must be filed shall be tolled from the time the Contractor submits the written claim until the time the claim is denied, including any time utilized for the meet and confer conference. Submission of a claim, properly certified, with all required supporting documentation, and written rejection or denial of all or part of the claim by the District, is a condition precedent to any action, proceeding, litigation, suit, general conditions claim, or demand for arbitration by Contractor.

G. **Government Code Claim.** In addition to any and all contract requirements pertaining to notices of and requests for compensation or payment for extra work, disputed work, construction claims and/or changed conditions, the Contractor must comply with the claim procedures set forth in Government Code sections 900 *et seq.* prior to filing any lawsuit against the District. Such Government Code claims and any subsequent lawsuit based upon the Government Code claims shall be limited to those matters that remain unresolved after all procedures pertaining to extra work, disputed work, construction claims, and/or changed conditions have been followed by Contractor. If no such Government Code claim is submitted, or if the prerequisite contractual requirements are not otherwise satisfied as specified herein, Contractor shall be barred from bringing and maintaining a valid lawsuit against the District.

ARTICLE 49 DISTRICT'S RIGHT TO TERMINATE CONTRACT

A. Termination for Cause by the District:

1. In the sole estimation of the District, if the Contractor refuses or fails to prosecute the Work or any separable part thereof with such diligence as will

GENERAL CONDITIONS
SECTION F- LABOR AND CONSTRUCTION

insure its completion within the time specified by the Contract Documents, or any extension thereof, or fails to complete such Work within such time, or if the Contractor should be adjudged a bankrupt, or if it should make a general assignment for the benefit of its creditors, or if a receiver should be appointed on account of its insolvency, or the Contractor or any of its subcontractors should violate any of the provisions of this Contract, the District may serve written notice upon the Contractor and its Surety of the District's intention to terminate this Contract. This notice of intent to terminate shall contain the reasons for such intention to terminate this Contract, and a statement to the effect that the Contractor's right to perform this Contract shall cease and terminate upon the expiration of ten (10) calendar days unless such violations have ceased and arrangements satisfactory to the District have been made for correction of said violations.

2. In the event that the District serves such written notice of termination upon the Contractor and the Surety, the Surety shall have the right to take over and perform the Contract. If the Surety does not: (1) give the District written notice of Surety's intention to take over and commence performance of the Contract within 15 calendar days of the District's service of said notice of intent to terminate upon Surety; and (2) actually commence performance of the Contract within 30 calendar days of the District's service of said notice upon Surety; then the District may take over the Work and prosecute the same to completion by separate contract or by any other method it may deem advisable for the account and at the expense of the Contractor.
3. In the event that the District elects to obtain an alternative performance of the Contract as specified above: (1) the District may, without liability for so doing, take possession of and utilize in completion of the Work such materials, appliances, plants and other property belonging to the Contractor that are on the site and reasonably necessary for such completion (A special lien to secure the claims of the District in the event of such suspension is hereby created against any property of Contractor taken into the possession of the District under the terms hereof and such lien may be enforced by sale of such property under the direction of the District Board without notice to Contractor. The proceeds of the sale after deducting all expenses thereof and connected therewith shall be credited to Contractor. If the net credits shall be in excess of the claims of the District against Contractor, the balance will be paid to Contractor or Contractor's legal representatives.); and (2) Surety shall be liable to the District for any cost or other damage to the District necessitated by the District securing an alternate performance pursuant to this Article.

B. Termination for Convenience by the District:

1. The District may terminate performance of the Work called for by the Contract Documents in whole or, from time to time, in part, if the District determines that a termination is in the District's interest.
2. The Contractor shall terminate all or any part of the Work upon delivery to the Contractor of a Notice of Termination specifying that the termination is for the

GENERAL CONDITIONS
SECTION F- LABOR AND CONSTRUCTION

convenience of the District, the extent of termination, and the Effective Date of such termination.

3. After receipt of Notice of Termination, and except as directed by the District's Representative, the Contractor shall, regardless of any delay in determining or adjusting any amounts due under this Termination for Convenience clause, immediately proceed with the following obligations:
 - a. Stop Work as specified in the Notice.
 - b. Complete any Work specified in the Notice of Termination in a least cost/shortest time manner while still maintaining the quality called for under the Contract Documents.
 - c. Leave the property upon which the Contractor was working and upon which the facility (or facilities) forming the basis of the Contract Document is situated in a safe and sanitary manner such that it does not pose any threat to the public health or safety.
 - d. Terminate all subcontracts to the extent that they relate to the portions of the Work terminated.
 - e. Place no further subcontracts or orders, except as necessary to complete the continued portion of the Contract.
 - f. Submit to the District's Representative, within ten (10) calendar days from the Effective Date of the Notice of Termination, all of the usual documentation called for by the Contract Documents to substantiate all costs incurred by the Contractor for labor, materials and equipment through the Effective Date of the Notice of Termination. Any documentation substantiating costs incurred by the Contractor solely as a result of the District's exercise of its right to terminate this Contract pursuant to this clause, which costs the contractor is authorized under the Contract documents to incur, shall: (1) be submitted to and received by the Engineer no later than 30 calendar days after the Effective Date of the Notice of Termination; (2) describe the costs incurred with particularity; and (3) be conspicuously identified as "Termination Costs occasioned by the District's Termination for Convenience."
4. Termination of the Contract shall not relieve Surety of its obligation for any just claims arising out of or relating to the Work performed.
5. In the event that the District exercises its right to terminate this Contract pursuant to this clause, the District shall pay the Contractor, upon the Contractor's submission of the documentation required by this clause and other applicable provisions of the Contract Documents, the following amounts:
 - a. All actual reimbursable costs incurred according to the provisions of this Contract.

GENERAL CONDITIONS
SECTION F- LABOR AND CONSTRUCTION

- b. A reasonable allowance for profit on the cost of the Work performed, provided Contractor establishes to the satisfaction of the District's Representative that it is reasonably probable that Contractor would have made a profit had the Contract been completed and provided further, that the profit allowed shall in no event exceed fifteen (15%) percent of the costs.
 - c. A reasonable allowance for Contractor's administrative costs in determining the amount payable due to termination of the Contract under this Article.
6. Notwithstanding any other provision of this Article, when immediate action is necessary to protect life and safety or to reduce significant exposure or liability, the District may immediately order Contractor to cease Work on the Project until such safety or liability issues are addressed to the satisfaction of the District or the Contract is terminated.

ARTICLE 50 WARRANTY AND GUARANTEE OF WORK

- A. Contractor hereby warrants that materials and Work shall be completed in conformance with the Contract Documents and that the materials and Work provided will fulfill the requirements of this Warranty. Contractor hereby agrees to repair or replace, at the discretion of the District, any or all Work that may prove to be defective in its workmanship, materials furnished, methods of installation or fail to conform to the Contract Document requirements together with any other Work which may be damaged or displaced by such defect(s) within a period of one (1) year from the date of the Notice of Completion of the Project without any expense whatever to the District, ordinary wear and tear and unusual abuse and neglect excepted. Contractor shall be required to promptly repair or replace defective equipment or materials, at Contractor's option. All costs associated with such corrective actions and testing, including the removal, replacement, and reinstatement of equipment and materials necessary to gain access, shall be the sole responsibility of the Contractor.
- B. For any Work so corrected, Contractor's obligation hereunder to correct defective Work shall be reinstated for an additional one (1) year period, commencing with the date of acceptance of such corrected Work. The reinstatement of the one (1) year warranty shall apply only to that portion of work that was corrected. Contractor shall perform such tests as District may require to verify that any corrective actions, including, without limitation, redesign, repairs, and replacements comply with the requirements of the Contract. In the event of Contractor's failure to comply with the above-mentioned conditions within ten (10) calendar days after being notified in writing of required repairs, to the reasonable satisfaction of the District, the District shall have the right to correct and replace any defective or non-conforming Work and any work damaged by such work or the replacement or correction thereof at Contractor's sole expense. Contractor shall be obligated to fully reimburse the District for any expenses incurred hereunder immediately upon demand.

GENERAL CONDITIONS
SECTION F- LABOR AND CONSTRUCTION

- C. In addition to the warranty set forth in this Article, Contractor shall obtain for District all warranties that would be given in normal commercial practice and assign to District any and all manufacturer's or installer's warranties for equipment or materials not manufactured by Contractor and provided as part of the Work, to the extent that such third-party warranties are assignable and extend beyond the warranty period set forth in this Article. Contractor shall furnish the District with all warranty and guarantee documents prior to final Acceptance of the Project by the District as required.
- D. When specifically indicated in the Contract Documents or when directed by the Engineer, the District may furnish materials or products to the Contractor for installation. In the event any act or failure to act by Contractor shall cause a warranty applicable to any materials or products purchased by the District for installation by the Contractor to be voided or reduced, Contractor shall indemnify District from and against any cost, expense, or other liability arising therefrom, and shall be responsible to the District for the cost of any repairs, replacement or other costs that would have been covered by the warranty but for such act or failure to act by Contractor.
- E. The Contractor shall remedy at its expense any damage to District-owned or controlled real or personal property.
- F. The District shall notify the Contractor, in writing, within a reasonable time after the discovery of any failure, defect, or damage. The Contractor shall within ten (10) calendar days after being notified commence and perform with due diligence all necessary Work. If the Contractor fails to promptly remedy any defect, or damage; the District shall have the right to replace, repair or otherwise remedy the defect, or damage at the Contractor's expense.
- G. In the event of any emergency constituting an immediate hazard to health, safety, property, or licensees, when caused by Work of the Contractor not in accordance with the Contract requirements, the District may undertake at Contractor's expense, and without prior notice, all Work necessary to correct such condition.
- H. Acceptance of Defective Work.
 - 1. If, instead of requiring correction or removal and replacement of Defective Work, the District prefers to accept it, District may do so. Contractor shall pay all claims, costs, losses, and damages (including but not limited to all fees and charges of engineers, architects, attorneys, and other professionals and all court or arbitration or other dispute resolution costs) attributable to District's evaluation of and determination to accept such Defective Work and for the diminished value of the Work.
 - 2. If any acceptance of defective work occurs prior to release of the Project Retention, a Change Order will be issued incorporating the necessary revisions in the Contract Documents with respect to the Work, and District shall be entitled to an appropriate decrease in the Contract Price, reflecting the diminished value of Work and all costs incurred by District.

GENERAL CONDITIONS
SECTION F- LABOR AND CONSTRUCTION

3. If the Project Retention is held in an escrow account as permitted by the Contract Documents, Contractor will promptly alert the escrow holder, in writing, of the amount of Retention to be paid to District.
 4. If the acceptance of Defective Work occurs after release of the Project Retention, an appropriate amount will be paid by Contractor to District.
- I. District May Correct Defective Work.
1. If Contractor fails within a reasonable time after written notice from District's Representative to correct Defective Work, or to remove and replace rejected Work as required by District, or if Contractor fails to perform the Work in accordance with the Contract Documents, or if Contractor fails to comply with any other provision of the Contract Documents, District may, after seven (7) Days' written notice to Contractor, correct, or remedy any such deficiency.
 2. In connection with such corrective or remedial action, District may exclude Contractor from all or part of the Site, take possession of all or part of the Work and suspend Contractor's services related thereto, take possession of Contractor's tools, appliances, construction equipment and machinery at the Site, and incorporate in the Work all materials and equipment stored at the Site or for which District has paid Contractor but which are stored elsewhere. Contractor shall allow District and District's Representative, and the agents, employees, other contractors, and consultants of each of them, access to the Site to enable District to exercise the rights and remedies to correct the Defective Work.
 3. All claims, costs, losses, and damages (including but not limited to all fees and charges of engineers, architects, attorneys, and other professionals and all court or arbitration or other dispute resolution costs) incurred or sustained by District correcting the Defective Work will be charged against Contractor, and a Change Order will be issued incorporating the necessary revisions into the Contract Documents with respect to the Work; and District shall be entitled to an appropriate decrease in the Contract Price.
 4. Such claims, costs, losses and damages will include, but not be limited to, all costs of repair, or replacement of work of others destroyed or damaged by correction, removal, or replacement of Defective Work.
 5. If the Change Order is executed after all payments under the Contract have been paid by District and the Project Retention is held in an escrow account as permitted by the Contract Documents, Contractor will promptly alert the escrow holder, in writing, of the amount of Retention to be paid to District.
 6. If the Change Order is executed after release of the Project Retention, an appropriate amount will be paid by Contractor to District.
 7. Contractor shall not be allowed an extension of the Contract Times because of any delay in the performance of the Work attributable to District correcting Defective work.

GENERAL CONDITIONS
SECTION F- LABOR AND CONSTRUCTION

- J. Nothing in the Warranty or in the Contract Documents shall be construed to limit the rights and remedies available to District at law or in equity, including, but not limited to, Code of Civil Procedure section 337.15.

ARTICLE 51 DOCUMENT RETENTION & EXAMINATION

- A. In accordance with Government Code section 8546.7, records of both the District and the Contractor shall be subject to examination and audit by the State Auditor General for a period of three (3) years after final payment.
- B. Contractor shall make available to the District any of the Contractor's other documents related to the Project immediately upon request of the District.
- C. In addition to the State Auditor rights above, the District shall have the right to examine and audit all books, estimates, records, contracts, documents, bid documents, subcontracts, and other data of the Contractor (including computations and projections) related to negotiating, pricing, or performing the modification in order to evaluate the accuracy and completeness of the cost or pricing data at no additional cost to the District, for a period of four (4) years after final payment.

ARTICLE 52 SEPARATE CONTRACTS

- A. The District reserves the right to let other contracts in connection with this Work or on the Project site. Contractor shall permit other contractors reasonable access and storage of their materials and execution of their work and shall properly connect and coordinate its Work with theirs.
- B. To ensure proper execution of its subsequent Work, Contractor shall immediately inspect work already in place and shall at once report to the Engineer any problems with the Work in place or discrepancies with the Contract Documents.
- C. Contractor shall ascertain to its own satisfaction the scope of the Project and nature of any other contracts that have been or may be awarded by the District in prosecution of the Project to the end that Contractor may perform this Contract in the light of such other contracts, if any. Nothing herein contained shall be interpreted as granting to Contractor exclusive occupancy at site of the Project. Contractor shall not cause any unnecessary hindrance or delay to any other contractor working on the Project. If simultaneous execution of any contract for the Project is likely to cause interference with performance of some other contract or contracts, the Engineer shall decide which Contractor shall cease Work temporarily and which contractor shall continue or whether work can be coordinated so that contractors may proceed simultaneously. The District shall not be responsible for any damages suffered or for extra costs incurred by Contractor resulting directly or indirectly from award, performance, or attempted performance of any other contract or contracts on the Project site.

GENERAL CONDITIONS
SECTION F- LABOR AND CONSTRUCTION

ARTICLE 53 NOTICE AND SERVICE THEREOF

All notices shall be in writing and either served by personal delivery or mailed to the other party as designated in the Bid Forms. Written notice to the Contractor shall be addressed to Contractor's principal place of business unless Contractor designates another address in writing for service of notice. Notice to District shall be addressed to the District as designated in the Notice Inviting Bids unless District designates another address in writing for service of notice. Notice shall be effective upon receipt or five (5) calendar days after being sent by first class mail, whichever is earlier. Notice given by facsimile shall not be effective unless acknowledged in writing by the receiving party.

ARTICLE 54 NOTICE OF THIRD PARTY CLAIMS

Pursuant to Public Contract Code section 9201, the District shall provide the Contractor with timely notification of the receipt of any third-party claims relating to the Contract. The District is entitled to recover reasonable costs incurred in providing such notification.

ARTICLE 55 STATE LICENSE BOARD NOTICE

Contractors are required by law to be licensed and regulated by the Contractors' State License Board which has jurisdiction to investigate complaints against contractors if a complaint regarding a patent act or omission is filed within four (4) years of the date of the alleged violation. A complaint regarding a latent act or omission pertaining to structural defects must be filed within ten (10) years of the date of the alleged violation. Any questions concerning a contractor may be referred to the Registrar, Contractors' State License Board, P.O. Box 26000, Sacramento, California 95826.

ARTICLE 56 INTEGRATION

- A. **Oral Modifications Ineffective.** No oral order, objection, direction, claim or notice by any party or person shall affect or modify any of the terms or obligations contained in the Contract Documents.
- B. **Contract Documents Represent Entire Contract.** The Contract Documents represent the entire agreement of the District and Contractor.

ARTICLE 57 ASSIGNMENT OF CONTRACT

Contractor shall not assign, transfer, convey, sublet or otherwise dispose of the rights or title of interest of any or all of this contract without the prior written consent of the District. Any assignment or change of Contractor's name of legal entity without the written consent of the District shall be void. Any assignment of money due or to become due under this Contract shall be subject to a prior lien for services rendered or Material supplied for performance of Work called for under the Contract Documents in favor of all persons, firms, or corporations rendering such services or supplying such Materials to the extent that claims are filed pursuant to the Civil Code, the Code of Civil Procedure or the Government Code.

GENERAL CONDITIONS
SECTION F- LABOR AND CONSTRUCTION

ARTICLE 58 CHANGE IN NAME AND NATURE OF CONTRACTOR'S LEGAL ENTITY

Should a change be contemplated in the name or nature of the Contractor's legal entity, the Contractor shall first notify the District in order that proper steps may be taken to have the change reflected on the Contract and all related documents. No change of Contractor's name or nature will affect District's rights under the Contract, including but not limited to the bonds.

ARTICLE 59 ASSIGNMENT OF ANTITRUST ACTIONS

Pursuant to Public Contract Code section 7103.5, in entering into a public works contract or subcontract to supply goods, services, or materials pursuant to a public works contract, Contractor or subcontractor offers and agrees to assign to the District all rights, title, and interest in and to all causes of action it may have under Section 4 of the Clayton Act (15 USC, Section 15) or under the Cartwright Act (Chapter 2 (commencing with Section 16700) of Part 2 of Division 7 of the Business and Professions Code), arising from the purchase of goods, services, or materials pursuant to this contract or any subcontract. This assignment shall be made and become effective at the time the District tenders final payment to the Contractor, without further acknowledgment by the parties.

ARTICLE 60 PROHIBITED INTERESTS

No District official or representative who is authorized in such capacity and on behalf of the District to negotiate, supervise, make, accept, or approve, or to take part in negotiating, supervising, making, accepting or approving any engineering, inspection, construction or material supply contract or any subcontract in connection with construction of the project, shall ARTICLE 11 be or become directly or indirectly interested financially in the Contract.

ARTICLE 61 CONTROLLING LAW

Notwithstanding any subcontract or other contract with any subcontractor, supplier, or other person or organization performing any part of the Work, this Contract shall be governed by the law of the State of California excluding any choice of law provisions.

ARTICLE 62 JURISDICTION; VENUE

Contractor and any subcontractor, supplier, or other person or organization performing any part of the Work agrees that any action or suits at law or in equity arising out of or related to the bidding, award, or performance of the Work shall be maintained in the Superior Court of Riverside County, California, and expressly consent to the jurisdiction of said court, regardless of residence or domicile, and agree that said court shall be a proper venue for any such action.

ARTICLE 63 LAWS AND REGULATIONS

- A. Contractor shall give all notices and comply with all laws, ordinances, rules and regulations bearing on conduct of work as indicated and specified. If Contractor observes that drawings and specifications are at variance therewith, it shall promptly notify the Engineer in writing and any necessary changes shall be adjusted as provided for in this Contract for changes in work. If Contractor performs any work knowing it to be contrary to such laws, ordinances, rules and

GENERAL CONDITIONS
SECTION F- LABOR AND CONSTRUCTION

regulations, and without such notice to the Engineer, it shall bear all costs arising therefrom.

- B. Contractor shall be responsible for familiarity with the Americans with Disabilities Act ("ADA") (42 U.S.C. § 12101 et seq.). The Work will be performed in ARTICLE 11 compliance with ADA regulations.

ARTICLE 64 PATENTS

Contractor shall hold and save the District, officials, officers, employees, and authorized volunteers harmless from liability of any nature or kind of claim therefrom including costs and expenses for or on account of any patented or unpatented invention, article or appliance manufactured, furnished or used by Contractor in the performance of this contract.

ARTICLE 65 OWNERSHIP OF CONTRACT DOCUMENTS

All Contract Documents furnished by the District are District property. They are not to be used by Contractor or any subcontractor on other work nor shall Contractor claim any right to such documents. With exception of one complete set of Contract Documents, all documents shall be returned to the District on request at completion of the Work.

ARTICLE 66 NOTICE OF TAXABLE POSSESSORY INTEREST

In accordance with Revenue and Taxation Code section 107.6, the Contract Documents may create a possessory interest subject to personal property taxation for which Contractor will be ARTICLE 11 responsible.

ARTICLE 67 SURVIVAL OF OBLIGATIONS

All representations, indemnifications, warranties, and guarantees made in, required by, or given in accordance with the Contract Documents, as well as all continuing obligations indicated in the Contract Documents, will survive final payment, completion, and acceptance of the Work or termination or completion of the Contract or termination of the services of Contractor.

**EXHIBIT "A"
CHANGE ORDER FORM**

Valley-Wide Recreation and Park District

*901 W. Esplanade Avenue
San Jacinto, California*

Contract Change Order #

| | | | |
|--|----------------------------------|--|------|
| Project: | Change Order No.: | | |
| | Orig. Contract Amt.: \$ | | Days |
| Contract No.: | | | |
| Contractor: | Prev. Appvd. Changes: \$ | | Days |
| Owner: Valley-Wide Recreation and Park District | This Change: \$ | | Days |
| | Revised Contract Amt.: \$ | | Days |

This Change Order covers changes to the subject contract as described herein. The Contractor shall construct, furnish equipment and materials, and perform all work as necessary or required to complete the Change Order items for a lump sum price agreed upon between the Contractor and Valley-Wide Recreation and Park District, otherwise referred to as Owner.

| Item No. | Description of Changes | Increase/ (Decrease) in Contract Amount | Contract Time Extension, Days |
|----------|------------------------|--|--|
| 1 | | | |
| 2 | | | |
| | Totals | \$ | |

This Contract Change Order consists of **2 pages** and any exhibits attached to this Contract Change Order shall not be part of the Contract Change Order unless specifically initiated by or on behalf of both the Contractor and the Valley-Wide Recreation and Park District.

Contract Change Order # _____ Page 1 of 2

The amount of the contract will be increased by the sum of \$_____ and the contract time shall be extended by working days. The undersigned Contractor approves the foregoing Change Order # as to the changes, if any, in the contract price specified for each item including any and all supervision costs and other miscellaneous costs relating to the change in work, and as to the extension of time allowed, if any, for completion of the entire work on account of said Change Order #. The Contractor agrees to furnish all labor and materials and perform all other necessary work, inclusive of the directly or indirectly related to the approved time extension, required to complete the Change order items. This document will become a supplement of the contract and all provisions will apply hereto. It is understood that the Change Order shall be effective when approved by the Owner.

Contractor accepts the terms and conditions stated above as full and final settlement of any and all claims arising out of or related to the subject of this Change Order and acknowledges that the compensation (time and cost) set forth herein comprises the total compensation due for the work or change defined in the Change Order, including all impact on any unchanged work. By signing this Change Order, the Contractor acknowledges and agrees that the stipulated compensation includes payment for all Work contained in the Change Order, plus all payment for any acceleration or interruption of schedules, extended overhead costs, delay, and all impact or cumulative impact on all Work under this Contract. The signing of this Change Order acknowledges full mutual accord and satisfaction for the change and that the stated time and/or cost constitute the total equitable adjustment owed the Contractor as a result of the change. The Contractor hereby releases and agrees to waive all rights, without exception or reservation of any kind whatsoever, to file any further claim or request for equitable adjustment of any type, for any reasonably foreseeable cause that shall arise out of, or as a result of, this Change Order and/or its impact on the remainder of the Work under the Contract.

Accepted:

 (Signature) Contractor's Authorized Representative

 Date

Recommended:

 (Signature) ****INSERT NAME, TITLE****

 Date

Approved:

 (Signature) ****INSERT NAME, TITLE****

 Date

| Item No. | Justification for Change(s) |
|----------|-----------------------------|
| 1 | |
| 2 | |

This Contract Change Order consists of **2 pages** and any exhibits attached to this Contract Change Order shall not be part of the Contract Change Order unless specifically initiated by or on behalf of both the Contractor and the Valley-Wide Recreation and Park District.

Contract Change Order #

Page 2 of 2

VALLEY-WIDE RECREATION
Valley-Wide Sports Center and
Winchester Park Accessibility Project Phase II

SECTION 00100 SC-SPECIAL CONDITIONS

SPECIAL PROVISIONS

SC-01. SCOPE OF WORK

Under these specifications the Contractor shall perform all work for the Regional Park Accessibility Improvement Project in accordance with these specifications and the contract drawings. The work generally consists but not limited to the following:

- Removing existing concrete, asphalt, base, vegetation, signs and other items.
- Constructing concrete curb and gutter, sidewalk, and ADA ramps
- Parking lot improvements
- Signing and striping
- Removal of architectural barriers within restroom
- All finished work to conform to the Americans with Disabilities Act (ADA) and California Building Code (CBC)

General

1. All work shall comply with District standards and specifications.
2. Contractor shall schedule a pre-job meeting 7 days prior to commencement of work.
3. Contractors shall provide submittals sheets of all proposed material prior to pre-job meeting.
4. All work shall be inspected by District. No trenches are permitted to be covered until approval by the District is obtained.
5. Contractor shall provide a detailed project schedule with durations of all scope of work.
6. Contractor shall be responsible for traffic control throughout the duration of all work. Traffic control must be provided per City of San Jacinto requirements including but not limited to an approved traffic control plan.
7. Contractor shall provide an encroachment permit for work within City of San Jacinto public right-of-way.
8. Contractor shall clean the project daily.
9. Contractor shall submit daily reports each day to District's representative.
10. Contractor shall maintain all new landscape areas for a period not less than 30 days from project installation completion acceptance by the District. Maintenance period does not commence until written approval is provided by the District.
11. Contractor acknowledges that roots and other organic material is present within all areas of work and no additional compensation will be given for time required to

complete scope of work within said conditions.

12. Retention shall be withheld per contract requirements until final acceptance has been provided by the District.

SC-02. SAFETY PROGRAM

Safety of all activities in connection with the work is of paramount and overriding importance.

Please note that the District reserves the right to suspend the work wholly or in part, for any time period as the district representative deems necessary, due to unresolved safety disputes.

No additional compensation or contract time will be allowed for the period the work is wholly or in part suspended.

Should the contract continue with the disputed work after having received a written notice of suspension, any work performed by the contractor during the suspension shall be considered as having been done by the contractor at the contractor's own risk as a volunteer, and shall not entitle the contractor to compensation or any other rights under the contract.

The Contractor shall conform to all applicable occupational safety and health standards, rules, regulations and orders established by local agencies, State of California, and California Division of Occupational Safety and Health Construction Safety Regulations (Cal Osha), including obtaining permits required by California Code of Regulations, Title 8, Sections 341 and 341 (a).

SC-03. PERFORMANCE AND PAYMENT BONDS

Pursuant to Section 995.660(a) of the Code of Civil Procedure, the Contractor shall submit the following documents with performance and payment bonds:

1. The original, or certified copy of the unrevoked appointment, power of attorney, bylaws, or other instrument entitling or authorizing their person who executed the bond to do so; and
2. A certified copy of the certificate of authority of the insurer issued by the State of California's Insurance Commissioner.

NO PAYMENT SHALL BE MADE UNTIL THE BONDS ARE APPROVED.

SC-04. LOCATION OF CONTRACT WORK SITE

The contract work site is located at Valley-Wide Regional Park – 901 W. Esplanade Avenue in the City of San Jacinto, California.

SC-05. LIQUIDATED DAMAGES

The fixed liquidated damages amount for each calendar day of unauthorized delay in completion of the work is hereby established at one thousand dollars (\$250) per calendar day.

SC-06. INSURANCE

At the times during the life of this contract, Contractor and his subcontractors shall procure and maintain Commercial Liability, Automobile Liability and Workers Compensation.

SC-07. PRECONSTRUCTION CONFERENCE

A Pre-job Conference shall be scheduled prior to the start of the project. District and Contractor representative shall be present.

SC-08. TRAFFIC CONTROL PLAN

It shall be the Contractor's responsibility to implement the approved traffic control plans. Contractor shall purchase or rent and maintain traffic warning signs, barricades, flagmen and other traffic control devices as required and to maintain traffic flow, as required by agencies having jurisdiction over the roadways in the work area. The cost for this work shall be included in Bid Prices. No additional compensation and time extension will be provided.

SC-09. EQUIPMENT AND MATERIAL STORAGE

It is the Contractor's responsibility to legally store equipment and material associated with the performance of the work. If the Contractor has arranged for temporary storage on private property outside of the public-right-of-way, the Contractor shall provide to the District a copy of the written agreement between the landowner and the Contractor.

SC-10. NOISE RESTRICTIONS

- A. Contractor shall use only such equipment on the Work and in such state of repair so that the emission of sound therefrom is within the noise tolerance level of that equipment as established by Cal/OSHA.
- B. Contractor shall comply with the most restrictive of the following: (1) local sound control and noise level rules, regulations and ordinances and (2) the requirements contained in these Contract Documents, including hours of operation requirements.
- C. No internal combustion engine shall be operated on the Project without a muffler of the type recommended by the manufacturer. Should any muffler or other control device sustain damage or be determined to be ineffective or defective, the Contractor shall promptly remove the equipment and shall not return said equipment to the job until the device is repaired or replaced. Said noise and vibration level requirements shall apply to all equipment on the job or related to the job, including but not limited to, trucks, transit mixers or transit equipment that may or may not be owned by the Contractor.

SC-11. COORDINATION WITH OTHER CONTRACTORS

[NOT USED]

SC-12. MODIFICATION OF HOURS OF WORK

[NOT USED]

SC-13. DESIGNATION OF DISTRICT'S REPRESENTATIVE

Unless otherwise modified by District, Districts' Representative shall be Justin Schweitzer and can be contacted at (951) 654-1505 or Justin@GoRecreation.org.

SC-14. ENGINEER OF RECORD.

For purposes of this Project, the Engineer of Record or Engineer shall be:

Blaine A. Womer Civil Engineering

END OF SPECIAL CONDITIONS

County of Riverside
Housing & Workforce Solutions (HWS)

SPECIAL FEDERAL PROVISIONS

CONSTRUCTION BID DOCUMENT

Projects Over \$200,000

**Community Development Block Grant
Construction Activities**

Last Date of Revision: June 2023

SPECIAL FEDERAL PROVISIONS DOCUMENT INDEX

General Information

1. General Summary
 2. Hold Harmless Clause and Additional Insured-Insurance Requirements
 3. B-1 Federal Labor Standards Provisions (HUD 4010)
 4. B-2 Federal Prevailing Wage Decision (CA _____ Mod. _____)
 5. B-3 Project Sign (SAMPLE)
 6. B-5 County of Riverside Section 3 Affirmative Action Policy (Applicable for Projects \$200,000 or more)
 7. Additional Federal Requirements
-

Bid Forms

8. B-4 Certification of Bidder Regarding Non-segregated Facilities (Required for all Projects)
9. B-6 Bidder's Certification for Section 3 Compliance (Required for Projects \$200,000 or more)
10. B-6(SUB) Subcontractor Certification for Section 3 Compliance (Required for Projects \$200,000 or more)
11. B-7 Bidder's Certification on Federal Contract Requirements (Required for all Projects)
12. B-8 Questionnaire Regarding Bidders (Required for all Projects)
13. B-9 List of Subcontractors and Suppliers (Required for all Projects)

Must be completed by all Subcontractors

14. B-10 Subcontractor Certification for Section 3 Compliance (Required for Projects \$200,000 or more)
-

Post-Award Forms

15. PA-1 Performance Bond (100% of contract price) (Required for Projects \$200,000 or more)
16. PA-2 Payment Bond (Required for Projects \$200,000 or more)
17. PA-3 Subcontractor Questionnaire (Required for all Projects)
18. PA-4 Subcontractor Certification Regarding Non-segregated Facilities (Required for all Projects)
19. PA-5 Section 3 Summary Report (Required for Projects \$200,000 or more)
20. PA-6 Davis-Bacon Classifications and Pay Rates (Required for all Projects)

GENERAL SUMMARY

The following Federal Provisions and the attached exhibits herewith become binding on the contractor(s) and incorporated in the Bid Document in their entirety.

1. The Contractor and the Subcontractor(s) shall perform all work in accordance with the project plans and specifications, including all stipulations designed to meet diversified Federal Environmental Architectural, the Architectural Barriers Act of 1968, as amended; the Americans with Disabilities Act of 1990, Public Law 101-336, as amended.
2. The Contractor and the Subcontractor(s) shall allow all authorized Federal, State Comptroller, and/or County officials access to the work area, fiscal, payroll, materials and other relevant contract records which are directly pertinent to that specific contract for the purpose of making audit, examination, excerpts, and transcriptions. All relevant records must be retained for at least four years.
3. The Contractor and the Subcontractor(s) shall comply with the Lead Based Paint Poisoning Prevention Act and the Implementation Regulations (24 CFR 35) issued pursuant thereto and any amendments thereof.
4. The Contractor and the Subcontractor(s) shall comply with Section 503 of the Rehabilitation Act of 1973 (P.L. 93-112) and the Implementation Regulations (41 CFR 60-741) issued pursuant thereto and any amendments thereof.
5. The Contractor and the Subcontractor(s) shall comply with Section 40-2, Vietnam Era Veterans Adjustment Assistance Act of 1974 and the Implementation Regulations (41 CFR 60-250) issued pursuant thereto and any amendment thereof.
6. The Contractor and the Subcontractor(s) shall comply with the Title IV of the Civil Rights Act of 1964 and the Title VIII of the Civil Rights Act of 1963 and any amendment thereof.
7. For projects \$200,000 or over, the Contractor and the Subcontractor(s) shall comply with Clean Air Act of 1963 (P.L. 90-148) and the Federal Water Pollution Act (P.L. 92-500), as amended and all applicable standards or regulations (40 CFR Part 15 and 61) issued pursuant to the said acts.
8. For projects \$2,000 or over, the Contractor and the Subcontractor(s) shall comply with the Davis-Bacon Fair Labor Standards Act (40 USC a-276 a-5), and the implementation regulations issued pursuant thereto (29 CFR Section 1, 5) and any amendments thereof. Pursuant to the said regulations, Exhibit B-1 and B-2 entitled “Federal Labor Standards Provisions” and “Federal Prevailing Wage Decision” respectively are herewith attached.
9. The Contractor and Subcontractor(s) shall comply with the Copeland Anti Kickback Act (40 USC 276 C) and the Implementation regulations (29 CFR 3) issued pursuant thereto and any amendments thereof. Exhibit B-1 contains the key provisions of the said act.

10. For construction projects \$2,000 or over, or other projects \$2,500 or more which utilize mechanics or laborers the Contractor and the Subcontractor(s) shall comply with the Contract Work Hours and Safety Standards Act (40 USC 327-332) and the Implementation Regulations (29 CFR 5) issued pursuant thereto and any amendments thereof. **Exhibit B-1** contains the key provisions of the said act.
11. For projects \$25,000 or over the Contractor shall provide one sign board to be located as directed by the owner. The sign board shall be mounted in an acceptable manner and constructed as shown and specified in **Exhibit B-3**. Additional information can be added to the project sign at the request of the project sponsor.
12. The Contractor shall comply with all laws, ordinances and regulations applicable to the work. If the Contractor ascertains at any time that any of the requirements of the contract are at variance with applicable law, ordinances, regulations or building code requirements, he shall promptly notify the owner and the Executive Director of Riverside County's Department of Housing & Workforce Solutions and shall not proceed with the work in question, except at his own risk, until the owner and the said Director has had an opportunity to determine the extent of the responsibility for the variance and the appropriate corrective actions undertaken.
13. The Contractor must complete and execute the attached Certification of Bidder Regarding Segregated Facilities **Exhibit B-4** and submit with the bid.
14. Wherever applicable, the Contractor and the Subcontractor(s) shall comply with, Uniform Administrative Requirements for Grants and Cooperative Agreements to State, Local and Federally Recognized Indian Tribal Governments, 24 CFR Part 85 or Uniform Requirements for Assistance to State and Local Governments, Circular A-102; Whichever is applicable.
15. For projects \$200,000 or over the Contractor shall furnish to the owner, a Performance bond, a Payment bond, and Materials Bond executed as surety by a corporation acceptable to the owner and authorized to issue surety bonds in the State of California. Such a performance bond and a payment bond and materials bond shall be for one hundred percent (100%) of the total contract price. (Attached herewith are recommended formats for said bonds, **Exhibits PA-1 and PA-2**.)
16. The Contractor and the Subcontractor(s) shall comply with Section 3 of The Housing and Community Development Act of 1968 and the regulations (24 CFR Part 75) issued pursuant thereto and amendments thereof. Pursuant to the said act, the Contractor and the Subcontractor(s) shall comply with the attached County of Riverside Section 3 Policy and Requirements **Exhibits B-5, B-6, and PA-6**. The Contractor must submit **Exhibit B-6**, for all projects over \$200,000, as part of the bid package.
17. The Contractor must submit the attached, **Exhibit B-7**, certification that "he/she fully understands the diversified Federal requirements imposed on the Contractor(s) of HUD funded construction projects", as part of the bid package.

18. Wherever applicable, the Contractor and the Sub-contractor(s) shall comply with Section 109 of The Housing and Community Development Act of 1974 and the Implementation Regulations (24 CFR 570.601) issued pursuant thereto and any amendments thereof.
19. For projects \$200,000 or over the Contractor shall submit a Bid Guarantee Bond in an amount no less than 5% of the total contract price, along with the bid.
20. The Contractor and Sub-contractor(s) shall comply with the Affirmative Action Reporting Requirements by completing the attachment **Exhibit B-6 and B-6 Sub** entitled, "Contractor Certification for Affirmative Action," and submit with bid for all projects \$200,000 and over.
21. Federal Employee Benefit Clause: No member of or delegate to the congress of the United States, and no Resident Commissioner shall be admitted to any share or part of this agreement or to any benefit to arise from the same.
22. The Contractor must submit Questionnaire Regarding Bidders **Exhibit B-8** and List of Sub-contractors **Exhibit B-9** as part of the bid package. These forms are considered part of the Federal Contracting Requirements and are included in the bid document. Both documents are required to be completed by the Prime Contractor.
23. The Contractor shall follow mandatory standards and policies relating to energy efficiency which are contained in the state energy conservation plan issued in compliance with the Energy Policy and Conservation Act (Pub. L. 94-163, 89 Stat. 871). [53 FR 8068,8087, Mar. 11, 1988, as amended at 60 FR 19639,19642, April 19, 1995]
24. Contractor must comply with awarding agency (HUD) requirements and regulations pertaining to copyrights and rights in data.
25. Contractor will comply with Notice of awarding agency requirements and regulations pertaining to patent rights with respect to any discovery or invention which arises or is developed in the course of or under such contract.
26. Contractor will comply with notice of awarding agency requirements and regulations pertaining to reporting.

HOLD HARMLESS CLAUSE/INSURANCE REQUIREMENTS

The following County of Riverside Hold Harmless and Insurance provisions herewith become binding on the contractor(s) in their entirety.

HOLD HARMLESS/INDEMNIFICATION

CONTRACTOR shall indemnify and hold harmless the County of Riverside, its Agencies, Districts, Special Districts and Departments, their respective directors, officers, Board of Supervisors, elected and appointed officials, employees, agents and representatives (individually and collectively hereinafter referred to as Indemnitees) from any liability whatsoever, based or asserted upon any services of CONTRACTOR, its officers, employees, subcontractors, agents or representatives arising out of or in any way relating to this Agreement, including but not limited to property damage, bodily injury, or death or any other element of any kind or nature whatsoever arising from the performance of CONTRACTOR, its officers, employees, subcontractors, agents or representatives Indemnitors from this Agreement. CONTRACTOR shall defend, at its sole expense, all costs and fees including, but not limited, to attorney fees, cost of investigation, defense and settlements or awards, the Indemnitees in any claim or action based upon such alleged acts or omissions.

With respect to any action or claim subject to indemnification herein by CONTRACTOR, CONTRACTOR shall, at their sole cost, have the right to use counsel of their own choice and shall have the right to adjust, settle, or compromise any such action or claim without the prior consent of COUNTY; provided, however, that any such adjustment, settlement or compromise in no manner whatsoever limits or circumscribes CONTRACTOR'S indemnification to Indemnitees as set forth herein.

CONTRACTOR'S obligation hereunder shall be satisfied when CONTRACTOR has provided to COUNTY the appropriate form of dismissal relieving COUNTY from any liability for the action or claim involved. The specified insurance limits required in this Agreement shall in no way limit or circumscribe CONTRACTOR'S obligations to indemnify and hold harmless the Indemnitees herein from third party claims. In the event there is conflict between this clause and California Civil Code Section 2782, this clause shall be interpreted to comply with Civil Code 2782. Such interpretation shall not relieve the CONTRACTOR from indemnifying the Indemnitees to the fullest extent allowed by law.

INSURANCE

Without limiting or diminishing the CONTRACTOR'S obligation to indemnify or hold the COUNTY harmless, CONTRACTOR shall procure and maintain or cause to be maintained, at its sole cost and expense, the following insurance coverage's during the term of this Agreement. As respects to the insurance section only, the COUNTY herein refers to the County of Riverside, its Agencies, Districts, Special Districts, and Departments, their respective directors, officers, Board of Supervisors, employees, elected or appointed officials, agents or representatives as Additional Insureds.

A. Workers' Compensation:

If the CONTRACTOR has employees as defined by the State of California, the CONTRACTOR shall maintain statutory Workers' Compensation Insurance (Coverage A) as prescribed by the laws of the State of California. Policy shall include Employers' Liability (Coverage B) including Occupational Disease with limits not less than \$1,000,000 per person per accident. The policy shall be endorsed to waive subrogation in favor of The County of Riverside.

B. Commercial General Liability:

Commercial General Liability insurance coverage, including but not limited to, premises liability, unmodified contractual liability, products and completed operations liability, personal and advertising injury, and cross liability coverage, covering claims which may arise from or out of CONTRACTOR'S performance of its obligations hereunder. Policy shall name the COUNTY as Additional Insured. Policy's limit of liability shall not be less than \$1,000,000 per occurrence combined single limit. If such insurance contains a general aggregate limit, it shall apply separately to this agreement or be no less than two (2) times the occurrence limit.

C. Vehicle Liability:

If vehicles or mobile equipment are used in the performance of the obligations under this Agreement, then CONTRACTOR shall maintain liability insurance for all owned, non-owned or hired vehicles so used in an amount not less than \$1,000,000 per occurrence combined single limit. If such insurance contains a general aggregate limit, it shall apply separately to this agreement or be no less than two (2) times the occurrence limit. Policy shall name the COUNTY as Additional Insureds.

D. Professional Liability (ONLY TO BE INCLUDED IN CONTRACTS WITH SERVICE PROVIDERS INCLUDING BUT NOT LIMITED TO ENGINEERS, DOCTORS, AND LAWYERS) Contractor shall maintain Professional Liability Insurance providing coverage for the Contractor's performance of work included within this Agreement, with a limit of liability of not less than \$1,000,000 per occurrence and \$2,000,000 annual aggregate. If Contractor's Professional Liability Insurance is written on a claims made basis rather than an occurrence basis, such insurance shall continue through the term of this Agreement and CONTRACTOR shall purchase at his sole expense either 1) an Extended Reporting Endorsement (also, known as Tail Coverage); or 2) Prior Dates Coverage from new insurer with a retroactive date back to the date of, or prior to, the inception of this Agreement; or 3) demonstrate through Certificates of Insurance that Contractor has Maintained continuous coverage with the same or original insurer. Coverage provided under items; 1), 2) or 3) will continue for a period of five (5) years beyond the termination of this Agreement.

E. General Insurance Provisions- All Lines:

a) Any insurance carrier providing insurance coverage hereunder shall be admitted to the State of California and have an A M BEST rating of not less than A: VIII (A:8) unless such requirements are waived, in writing, by the County Risk Manager. If the County's Risk Manager waives a requirement for a particular insurer such waiver is only valid for that specific insurer and only for one policy term.

b) The Contractor's insurance carrier(s) must declare its insurance deductibles or self-insured retentions. If such deductibles or self-insured retentions exceed \$500,000 per

occurrence such deductibles and/or retentions shall have the prior written consent of the County Risk Manager before the commencement of operations under this Agreement. Upon notification of deductibles or self insured retention's unacceptable to the County, and at the election of the County's Risk Manager, Contractor's carriers shall either; 1) reduce or eliminate such deductibles or self-insured retention's as respects this Agreement with the County, or 2) procure a bond which guarantees payment of losses and related investigations, claims administration, and defense costs and expenses.

c) Contractor shall cause Contractor's insurance carrier(s) to furnish the County of Riverside with either 1) a properly executed original Certificate(s) of Insurance and certified original copies of Endorsements effecting coverage as required herein, or 2) if requested to do so orally or in writing by the County Risk Manager, provide original Certified copies of policies including all Endorsements and all attachments thereto, showing such insurance is in full force and effect. Further, said Certificate(s) and policies of insurance shall contain the covenant of the insurance carrier(s) that thirty (30) days written notice shall be given to the County of Riverside prior to any material modification, cancellation, expiration or reduction in coverage of such insurance. In the event of a material modification, cancellation, expiration, or reduction in coverage, this Agreement shall terminate forthwith, unless the County of Riverside receives, prior to such effective date, another properly executed original Certificate of Insurance and original copies of endorsements or certified original policies, including all endorsements and attachments thereto evidencing coverage's set forth herein and the insurance required herein is in full force and effect. *Contractor shall not commence operations until the County has been furnished original Certificate (s) of Insurance and certified original copies of endorsements or policies of insurance including all endorsements and any and all other attachments as required in this Section. An individual authorized by the insurance carrier to do on its behalf shall sign the original endorsements for each policy and the Certificate of Insurance.*

d) It is understood and agreed to by the parties hereto and the insurance company(s), that the Certificate(s) of Insurance and policies shall so covenant and shall be construed as primary insurance, and the County's insurance and/or deductibles and/or self-insured retention's or self-insured programs shall not be construed as contributory.

e) The County's Reserved Rights--Insurance. If, during the term of this Agreement or any extension thereof, there is a material change in the scope of services; or, there is a material change in the equipment to be used in the performance of the scope of work (such as the use of aircraft or watercraft) the County reserves the right to adjust the types of insurance required under this Agreement and the monetary limits of liability for the insurance coverage's currently required herein, if; in the County Risk Manager's reasonable judgment, the amount or type of insurance carried by the Contractor has become inadequate.

f) Contractor shall pass down the insurance obligations contained herein to all tiers of subcontractors working under this Agreement. g) The insurance requirements contained in this agreement may be met with a program(s) of self-insurance acceptable to the County.

EXHIBIT B-1

**HUD-4010
Federal Labor Standards Provisions**

**U.S. Department of Housing and Urban Development
Office of Davis-Bacon and Labor Standards**

A. APPLICABILITY

The Project or Program to which the construction work covered by this Contract pertains is being assisted by the United States of America, and the following Federal Labor Standards Provisions are included in this Contract pursuant to the provisions applicable to such Federal assistance.

(1) MINIMUM WAGES

- (i) All laborers and mechanics employed or working upon the site of the work will be paid unconditionally and not less often than once a week, and without subsequent deduction or rebate on any account (except such payroll deductions as are permitted by regulations issued by the Secretary of Labor under the Copeland Act (29 CFR Part 3)), the full amount of wages and bona fide fringe benefits (or cash equivalents thereof) due at time of payment, computed at rates not less than those contained in the wage determination of the Secretary of Labor (which is attached hereto and made a part hereof), regardless of any contractual relationship which may be alleged to exist between the contractor and such laborers and mechanics. Contributions made or costs reasonably anticipated for bona fide fringe benefits under Section 1(b)(2) of the Davis-Bacon Act on behalf of laborers or mechanics are considered wages paid to such laborers or mechanics, subject to the provisions of 29 CFR 5.5(a)(1)(iv); also, regular contributions made or costs incurred for more than a weekly period (but not less often than quarterly) under plans, funds, or programs, which cover the particular weekly period, are deemed to be constructively made or incurred during such weekly period.

Such laborers and mechanics shall be paid the appropriate wage rate and fringe benefits on the wage determination for the classification of work actually performed, without regard to skill, except as provided in 29 CFR 5.5(a)(4). Laborers or mechanics performing work in more than one classification may be compensated at the rate specified for each classification for the time actually worked therein: Provided, that the employer's payroll records accurately set forth the time spent in each classification in which work is performed. The wage determination (including any additional classification and wage rates conformed under 29 CFR 5.5(a)(1)(ii) and the Davis-Bacon poster (WH1321)) shall be posted at all times by the contractor and its subcontractors at the site of the work in a prominent and accessible place, where it can be easily seen by the workers.

(ii) Additional Classifications.

- (A) Any class of laborers or mechanics which is not listed in the wage determination and which is to be employed under the contract shall be classified in conformance with the wage determination. HUD shall approve an additional classification and wage rate and fringe benefits therefor only when the following criteria have been met:
- (1) The work to be performed by the classification requested is not performed by a classification in the wage determination;
 - (2) The classification is utilized in the area by the construction industry; and
 - (3) The proposed wage rate, including any bona fide fringe benefits, bears a reasonable relationship to the wage rates contained in the wage determination.
- (B) If the contractor, the laborers and mechanics to be employed in the classification (if known), or their representatives, and HUD or its designee agree on the proposed classification and wage rate (including the amount designated for fringe benefits, where appropriate), a report of the action taken shall be sent by HUD or its designee to the Administrator of the Wage and Hour Division ("Administrator"), Employment Standards Administration, U.S. Department of Labor, Washington, D.C. 20210. The Administrator, or an authorized representative, will approve, modify, or disapprove every additional classification action within 30 days of receipt and so advise HUD or its designee or will notify HUD or its designee within the 30-day period that additional time is necessary. (Approved by the Office of Management and Budget ("OMB") under OMB control number 1235-0023.)
- (C) In the event the contractor, the laborers or mechanics to be employed in the classification or their representatives, or HUD or its designee do not agree on the proposed classification and wage rate (including the amount designated for fringe benefits, where appropriate), HUD or its designee shall refer the questions, including the views of all interested parties and the recommendation of HUD or its designee, to the Administrator for determination. The Administrator, or an authorized representative, will issue a determination within 30 days of receipt and so advise HUD or its designee or will notify HUD or its designee within the 30-day period that additional time is necessary. (Approved by the Office of Management and Budget under OMB Control Number 1235-0023.)

(D) The wage rate (including fringe benefits, where appropriate) determined pursuant to subparagraphs (1)(ii)(B) or (C) of this paragraph, shall be paid to all workers performing work in the classification under this Contract from the first day on which work is performed in the classification.

- (iii) Whenever the minimum wage rate prescribed in the contract for a class of laborers or mechanics includes a fringe benefit which is not expressed as an hourly rate, the contractor shall either pay the benefit as stated in the wage determination or shall pay another bona fide fringe benefit or an hourly cash equivalent thereof.
- (iv) If the contractor does not make payments to a trustee or other third person, the contractor may consider as part of the wages of any laborer or mechanic the amount of any costs reasonably anticipated in providing bona fide fringe benefits under a plan or program, Provided, that the Secretary of Labor has found, upon the written request of the contractor, that the applicable standards of the Davis-Bacon Act have been met. The Secretary of Labor may require the contractor to set aside in a separate account assets for the meeting of obligations under the plan or program. (Approved by the Office of Management and Budget under OMB Control Number 1235-0023.)

(2) **Withholding.** HUD or its designee shall, upon its own action or upon written request of an authorized representative of the U.S. Department of Labor, withhold or cause to be withheld from the contractor under this contract or any other Federal contract with the same prime contractor, or any other Federally-assisted contract subject to Davis-Bacon prevailing wage requirements which is held by the same prime contractor, so much of the accrued payments or advances as may be considered necessary to pay laborers and mechanics, including apprentices, trainees and helpers, employed by the contractor or any subcontractor the full amount of wages required by the contract. In the event of failure to pay any laborer or mechanic, including any apprentice, trainee or helper, employed or working on the site of the work, all or part of the wages required by the contract, HUD or its designee may, after written notice to the contractor, sponsor, applicant, or owner, take such action as may be necessary to cause the suspension of any further payment, advance, or guarantee of funds until such violations have ceased. HUD or its designee may, after written notice to the contractor, disburse such amounts withheld for and on account of the contractor or subcontractor to the respective employees to whom they are due. The U.S. Department of Labor shall make such disbursements in the case of direct Davis-Bacon Act contracts.

(3) **Payrolls and basic records.**

(i) **Maintaining Payroll Records.** Payrolls and basic records relating thereto shall be maintained by the contractor during the course of the work and preserved for a period of three years thereafter for all laborers and mechanics working at the site of the work. Such records shall contain the name, address, and social security number of each such worker, his or her correct classification(s), hourly rates of wages paid (including rates of contributions or costs anticipated for bona fide fringe benefits or cash equivalents thereof of the types described in Section 1(b)(2)(B) of the Davis-Bacon Act), daily and weekly number of hours worked, deductions made, and actual wages paid.

Whenever the Secretary of Labor has found, under 29 CFR 5.5(a)(1)(iv), that the wages of any laborer or mechanic include the amount of any costs reasonably anticipated in providing benefits under a plan or program described in Section 1(b)(2)(B) of the Davis-Bacon Act, the contractor shall maintain records which show that the commitment to provide such benefits is enforceable, that the plan or program is financially responsible, and that the plan or program has been communicated in writing to the laborers or mechanics affected, and records which show the costs anticipated or the actual cost incurred in providing such benefits.

Contractors employing apprentices or trainees under approved programs shall maintain written evidence of the registration of apprenticeship programs and certification of trainee programs, the registration of the apprentices and trainees, and the ratios and wage rates prescribed in the applicable programs. (Approved by the Office of Management and Budget under OMB Control Numbers 1235-0023 and 1215-0018)

(ii) **Certified Payroll Reports.**

(A) The contractor shall submit weekly, for each week in which any contract work is performed, a copy of all payrolls to HUD or its designee if the agency is a party to the contract, but if the agency is not such a party, the contractor will submit the payrolls to the applicant sponsor, or owner, as the case may be, for transmission to HUD or its designee. The payrolls submitted shall set out accurately and completely all of the information required to be maintained under 29 CFR 5.5(a)(3)(i), except that full social security numbers and home addresses shall not be included on weekly transmittals. Instead, the payrolls only need to include an individually identifying number for each employee (e.g., the last four digits of the employee's social security number). The required weekly payroll information may be submitted in any form desired. Optional Form WH-347 is available for this purpose from the Wage and Hour Division Web site at <https://www.dol.gov/agencies/whd/forms> or its successor site. The prime contractor is responsible for the submission of copies of payrolls by all subcontractors.

Contractors and subcontractors shall maintain the full social security number and current address of each covered worker, and shall provide them upon request to HUD or its designee if the agency is a party to the contract, but if the agency is not such a party, the contractor will submit the payrolls to the applicant sponsor, or owner, as the case may be, for transmission to HUD or its designee, the contractor, or the Wage and Hour Division of the U.S. Department of Labor for purposes of an investigation or audit of compliance with prevailing wage requirements. It is not a violation of this subparagraph for a prime contractor to require a subcontractor to provide addresses and social security numbers to the prime contractor for its own records, without weekly submission to HUD or its designee. (Approved by the Office of Management and Budget under OMB Control Number 1235-0008.)

- (B)** Each payroll submitted shall be accompanied by a "Statement of Compliance," signed by the contractor or subcontractor or his or her agent who pays or supervises the payment of the persons employed under the contract and shall certify the following:
- (1)** That the payroll for the payroll period contains the information required to be provided under 29 CFR 5.5(a)(3)(ii), the appropriate information is being maintained under 29 CFR 5.5(a)(3)(i), and that such information is correct and complete;
 - (2)** That each laborer or mechanic (including each helper, apprentice, and trainee) employed on the contract during the payroll period has been paid the full weekly wages earned, without rebate, either directly or indirectly, and that no deductions have been made either directly or indirectly from the full wages earned, other than permissible deductions as set forth in 29 CFR Part 3;
 - (3)** That each laborer or mechanic has been paid not less than the applicable wage rates and fringe benefits or cash equivalents for the classification of work performed, as specified in the applicable wage determination incorporated into the contract; and
- (C)** The weekly submission of a properly executed certification set forth on the reverse side of Optional Form WH-347 shall satisfy the requirement for submission of the "Statement of Compliance" required by subparagraph (a)(3)(ii)(b).
- (D)** The falsification of any of the above certifications may subject the contractor or subcontractor to civil or criminal prosecution under Section 1001 of Title 18 and Section 3729 of Title 31 of the United States Code.

(iii) The contractor or subcontractor shall make the records required under subparagraph (a)(3)(i) available for inspection, copying, or transcription by authorized representatives of HUD or its designee or the U.S. Department of Labor, and shall permit such representatives to interview employees during working hours on the job. If the contractor or subcontractor fails to submit the required records or to make them available, HUD or its designee may, after written notice to the contractor, sponsor, applicant, or owner, take such action as may be necessary to cause the suspension of any further payment, advance, or guarantee of funds. Furthermore, failure to submit the required records upon request or to make such records available may be grounds for debarment action pursuant to 29 CFR 5.12.

(4) Apprentices and Trainees.

(i) Apprentices. Apprentices will be permitted to work at less than the predetermined rate for the work they performed when they are employed pursuant to and individually registered in a bona fide apprenticeship program registered with the U.S. Department of Labor, Employment and Training Administration, Office of Apprenticeship Training, Employer and Labor Services, or with a State Apprenticeship Agency recognized by the Office, or if a person is employed in his or her first 90 days of probationary employment as an apprentice in such an apprenticeship program, who is not individually registered in the program, but who has been certified by the Office of Apprenticeship Training, Employer and Labor Services, or a State Apprenticeship Agency (where appropriate), to be eligible for probationary employment as an apprentice.

The allowable ratio of apprentices to journeymen on the job site in any craft classification shall not be greater than the ratio permitted to the contractor as to the entire work force under the registered program. Any worker listed on a payroll at an apprentice wage rate, who is not registered or otherwise employed as stated above, shall be paid not less than the applicable wage rate on the wage determination for the classification of work actually performed. In addition, any apprentice performing work on the job site in excess of the ratio permitted under the registered program shall be paid not less than the applicable wage rate on the wage determination for the work actually performed. Where a contractor is performing construction on a project in a locality other than that in which its program is registered, the ratios and wage rates (expressed in percentages of the journeyman's hourly rate) specified in the contractor's or subcontractor's registered program shall be observed.

Every apprentice must be paid at not less than the rate specified in the registered program for the apprentice's level of progress, expressed as a percentage of the journeymen hourly rate specified in the applicable wage determination.

Apprentices shall be paid fringe benefits in accordance with the provisions of the apprenticeship program.

If the apprenticeship program does not specify fringe benefits, apprentices must be paid the full amount of fringe benefits listed on the wage determination for the applicable classification. If the Administrator determines that a different practice prevails for the applicable apprentice classification, fringe benefits shall be paid in accordance with that determination. In the event the Office of Apprenticeship Training, Employer and Labor Services, or a State Apprenticeship Agency recognized by the Office, withdraws approval of an apprenticeship program, the contractor will no longer be permitted to utilize apprentices at less than the applicable predetermined rate for the work performed until an acceptable program is approved.

- (ii) **Trainees.** Except as provided in 29 CFR 5.16, trainees will not be permitted to work at less than the predetermined rate for the work performed, unless they are employed pursuant to and individually registered in a program which has received prior approval, evidenced by formal certification by the U.S. Department of Labor, Employment and Training Administration. The ratio of trainees to journeymen on the job site shall not be greater than permitted under the plan approved by the Employment and Training Administration. Every trainee must be paid at not less than the rate specified in the approved program for the trainee's level of progress, expressed as a percentage of the journeyman hourly rate specified in the applicable wage determination. Trainees shall be paid fringe benefits in accordance with the provisions of the trainee program. If the trainee program does not mention fringe benefits, trainees shall be paid the full amount of fringe benefits listed on the wage determination unless the Administrator of the Wage and Hour Division determines that there is an apprenticeship program associated with the corresponding journeyman wage rate on the wage determination which provides for less than full fringe benefits for apprentices. Any employee listed on the payroll at a trainee rate who is not registered and participating in a training plan approved by the Employment and Training Administration shall be paid not less than the applicable wage rate on the wage determination for the work actually performed.

In addition, any trainee performing work on the job site in excess of the ratio permitted under the registered program shall be paid not less than the applicable wage rate on the wage determination for the work actually performed. In the event the Employment and Training Administration withdraws approval of a training program, the contractor will no longer be permitted to utilize trainees at less than the applicable predetermined rate for the work performed until an acceptable program is approved.

- (iii) **Equal employment opportunity.** The utilization of apprentices, trainees, and journeymen under 29 CFR Part 5 shall be in conformity with the equal employment opportunity requirements of Executive Order 11246, as amended, and 29 CFR Part 30.

- (5) **Compliance with Copeland Act requirements.** The contractor shall comply with the requirements of 29 CFR Part 3, which are incorporated by reference in this Contract.
- (6) **Subcontracts.** The contractor or subcontractor will insert in any subcontracts the clauses contained in subparagraphs (1) through (11) in this paragraph (a) and such other clauses as HUD or its designee may, by appropriate instructions, require, and a copy of the applicable prevailing wage decision, and also a clause requiring the subcontractors to include these clauses in any lower tier subcontracts. The prime contractor shall be responsible for the compliance by any subcontractor or lower tier subcontractor with all the contract clauses in this paragraph.
- (7) **Contract termination; debarment.** A breach of the contract clauses in 29 CFR 5.5 may be grounds for termination of the contract and for debarment as a contractor and a subcontractor as provided in 29 CFR 5.12.
- (8) **Compliance with Davis-Bacon and Related Act Requirements.** All rulings and interpretations of the Davis-Bacon and Related Acts contained in 29 CFR Parts 1, 3, and 5 are herein incorporated by reference in this Contract.
- (9) **Disputes concerning labor standards.** Disputes arising out of the labor standards provisions of this Contract shall not be subject to the general disputes clause of this Contract. Such disputes shall be resolved in accordance with the procedures of the U.S. Department of Labor set forth in 29 CFR Parts 5, 6, and 7. Disputes within the meaning of this clause include disputes between the contractor (or any of its subcontractors) and HUD or its designee, the U.S. Department of Labor, or the employees or their representatives.
- (10) **Certification of Eligibility.**
- (i) By entering into this Contract, the contractor certifies that neither it (nor he or she) nor any person or firm who has an interest in the contractor's firm is a person or firm ineligible to be awarded Government contracts by virtue of Section 3(a) of the Davis-Bacon Act or 29 CFR 5.12(a)(1) or to be awarded HUD contracts or participate in HUD programs pursuant to 24 CFR Part 24.

- (ii) No part of this Contract shall be subcontracted to any person or firm ineligible for award of a Government contract by virtue of Section 3(a) of the Davis-Bacon Act or 29 CFR 5.12(a)(1) or to be awarded HUD contracts or participate in HUD programs pursuant to 24 CFR Part 24.
- (iii) Anyone who knowingly makes, presents, or submits a false, fictitious, or fraudulent statement, representation or certification is subject to criminal, civil and/or administrative sanctions, including fines, penalties, and imprisonment (e.g., 18 U.S.C. §§ 287, 1001, 1010, 1012; 31 U.S.C. §§ 3729, 3802).

(11) Complaints, Proceedings, or Testimony by Employees. No laborer or mechanic, to whom the wage, salary, or other labor standards provisions of this Contract are applicable, shall be discharged or in any other manner discriminated against by the contractor or any subcontractor because such employee has filed any complaint or instituted or caused to be instituted any proceeding or has testified or is about to testify in any proceeding under or relating to the labor standards applicable under this Contract to his employer.

B. CONTRACT WORK HOURS AND SAFETY STANDARDS ACT

The provisions of this paragraph (b) are applicable where the amount of the prime contract exceeds **\$100,000**. As used in this paragraph, the terms “laborers” and “mechanics” include watchmen and guards.

- (1) Overtime requirements.** No contractor or subcontractor contracting for any part of the contract work, which may require or involve the employment of laborers or mechanics, shall require or permit any such laborer or mechanic in any workweek in which the individual is employed on such work to work in excess of 40 hours in such workweek, unless such laborer or mechanic receives compensation at a rate not less than one and one-half times the basic rate of pay for all hours worked in excess of 40 hours in such workweek.
- (2) Violation; liability for unpaid wages; liquidated damages.** In the event of any violation of the clause set forth in subparagraph B(1) of this paragraph, the contractor, and any subcontractor responsible therefor, shall be liable for the unpaid wages. In addition, such contractor and subcontractor shall be liable to the United States (in the case of work done under contract for the District of Columbia or a territory, to such District or to such territory) for liquidated damages. Such liquidated damages shall be computed with respect to each individual laborer or mechanic, including watchmen and guards, employed in violation of the clause set forth in subparagraph B(1) of this paragraph, **in the sum set by the U.S. Department of Labor at 29 CFR 5.5(b)(2)** for each calendar day on which such individual was required or permitted to work in excess of the standard workweek of 40 hours without payment of the overtime wages required by the clause set forth in subparagraph B(1) of this paragraph. In accordance with the Federal Civil Penalties Inflation Adjustment Act of 1990 (28 U.S.C. § 2461 Note), the DOL adjusts this civil monetary penalty for inflation no later than January 15 each year.
- (3) Withholding for unpaid wages and liquidated damages.** HUD or its designee shall, upon its own action or upon written request of an authorized representative of the U.S. Department of Labor, withhold or cause to be withheld from any moneys payable on account of work performed by the contractor or subcontractor under any such contract, or any other Federal contract with the same prime contract, or any other Federally-assisted contract subject to the Contract Work Hours and Safety Standards Act which is held by the same prime contractor, such sums as may be determined to be necessary to satisfy any liabilities of such contractor or subcontractor for unpaid wages and liquidated damages, as provided in the clause set forth in subparagraph B(2) of this paragraph.
- (4) Subcontracts.** The contractor or subcontractor shall insert in any subcontracts the clauses set forth in subparagraph B(1) through (4) of this paragraph and also a clause requiring the subcontractors to include these clauses in any lower tier subcontracts. The prime contractor shall be responsible for compliance by any subcontractor or lower tier subcontractor with the clauses set forth in subparagraphs B(1) through (4) of this paragraph.

C. HEALTH AND SAFETY

The provisions of this paragraph (c) are applicable where the amount of the prime contract exceeds **\$100,000**.

- (1)** No laborer or mechanic shall be required to work in surroundings or under working conditions which are unsanitary, hazardous, or dangerous to his or her health and safety, as determined under construction safety and health standards promulgated by the Secretary of Labor by regulation.
- (2)** The contractor shall comply with all regulations issued by the Secretary of Labor pursuant to 29 CFR Part 1926 and failure to comply may result in imposition of sanctions pursuant to the Contract Work Hours and Safety Standards Act, (Public Law 91-54, 83 Stat 96), 40 U.S.C. § 3701 et seq.
- (3)** The contractor shall include the provisions of this paragraph in every subcontract, so that such provisions will be binding on each subcontractor. The contractor shall take such action with respect to any subcontractor as the Secretary of Housing and Urban Development or the Secretary of Labor shall direct as a means of enforcing such provisions.

FEDERAL PREVAILING WAGE DECISION

(CA _____ mod. _____)
Insert most recent (10 days prior to bid opening) wage decision at this point.

LABOR STANDARDS REQUIREMENTS - PRECONSTRUCTION PHASE. A construction project covered by Federal Labor Standards Provisions (HUD-4010) requires a series of specific actions prior to the actual start of construction. Those actions are:

- a. obtaining an applicable Davis-Bacon wage determination for the project;
- b. including that wage determination (and any modifications) in the bid documents where there is competitive bidding or in invitations for proposals; and
- c. including appropriate labor standards provisions and the wage determination in the construction contract.

CONSTRUCTION WAGE DETERMINATION - DEFINITION. All construction bid documents and contracts, or analogous instruments covered by the Federal Labor Standards Provisions (HUD-4010) must contain a current and applicable wage determination issued by the Department of Labor. The term “wage determination” includes the original decision and any subsequent decisions modifying, superseding, correcting, or otherwise changing the provisions of the original decision.

Reference: Handbook 1344.1 Federal Labor Standards Compliance in Housing and Community Development Programs'; paragraph 2-1, section 1 paragraph 1-1.

OBTAINING WAGE DETERMINATIONS

The Riverside County Department of Housing & Workforce Solutions (HWS) will be responsible to obtain and provide the appropriate Federal wage determination from the U.S. Department of Labor (DOL) for this project. The appropriate wage determination will be the most current determination, applicable for Riverside County and the construction type, that is effective ten (10) days before the opening of bids. Wage determinations shall be effective (locked-in) on the date that bids are opened provided that the contract is awarded within 90 days after bid opening. If the contract is awarded more than 90 days after bid opening, the wage determination shall be updated as of the date of award. If construction starts more than 90 days after contract award, the wage determination shall be updated as of the construction start date.

Superseded General Decision Number: CA20230025

State: California

Construction Types: Building, Heavy (Heavy and Dredging) and Highway

County: Riverside County in California.

BUILDING CONSTRUCTION PROJECTS; DREDGING PROJECTS (does not include hopper dredge work); HEAVY CONSTRUCTION PROJECTS (does not include water well drilling); HIGHWAY CONSTRUCTION PROJECTS

Note: Contracts subject to the Davis-Bacon Act are generally required to pay at least the applicable minimum wage rate required under Executive Order 14026 or Executive Order 13658. Please note that these Executive Orders apply to covered contracts entered into by the federal government that are subject to the Davis-Bacon Act itself, but do not apply to contracts subject only to the Davis-Bacon Related Acts, including those set forth at 29 CFR 5.1(a)(1).

| | |
|---|---|
| If the contract is entered into on or after January 30, 2022, or the contract is renewed or extended (e.g., an option is exercised) on or after January 30, 2022: | <ul style="list-style-type: none"> . Executive Order 14026 generally applies to the contract. . The contractor must pay all covered workers at least \$17.20 per hour (or the applicable wage rate listed on this wage determination, if it is higher) for all hours spent performing on the contract in 2024. |
| If the contract was awarded on or between January 1, 2015 and January 29, 2022, and the contract is not renewed or extended on or after January 30, 2022: | <ul style="list-style-type: none"> . Executive Order 13658 generally applies to the contract. . The contractor must pay all covered workers at least \$12.90 per hour (or the applicable wage rate listed on this wage determination, if it is higher) for all hours spent performing on that contract in 2024. |

The applicable Executive Order minimum wage rate will be adjusted annually. If this contract is covered by one of the Executive Orders and a classification considered necessary for performance of work on the contract does not appear on this wage determination, the contractor must still submit a conformance request.

Additional information on contractor requirements and worker protections under the Executive Orders is available at <http://www.dol.gov/whd/govcontracts>.

| Modification Number | Publication Date |
|---------------------|------------------|
| 0 | 01/05/2024 |
| 1 | 01/12/2024 |
| 2 | 01/19/2024 |
| 3 | 02/23/2024 |

ASBE0005-002 09/01/2023

| | Rates | Fringes |
|--|-------|---------|
|--|-------|---------|

| | | |
|--|----------|-------|
| Asbestos Workers/Insulator (Includes the application of all insulating materials, protective coverings, coatings, and finishes to all types of mechanical systems)..... | \$ 49.58 | 25.27 |
| Fire Stop Technician (Application of Firestopping Materials for wall openings and penetrations in walls, floors, ceilings and curtain walls)..... | \$ 36.97 | 20.36 |

ASBE0005-004 07/04/2022

| | Rates | Fringes |
|--|-------|---------|
|--|-------|---------|

| | | |
|--|----------|-------|
| Asbestos Removal worker/hazardous material handler (Includes preparation, wetting, stripping, removal, scrapping, vacuuming, bagging and disposing of all insulation materials from mechanical systems, whether they contain asbestos or not).... | \$ 23.52 | 13.37 |
|--|----------|-------|

BOIL0092-003 01/01/2024

| | Rates | Fringes |
|--|-------|---------|
|--|-------|---------|

| | | |
|------------------|----------|-------|
| BOILERMAKER..... | \$ 51.98 | 42.11 |
|------------------|----------|-------|

* BRCA0004-011 05/01/2020

| | Rates | Fringes |
|--|-------|---------|
|--|-------|---------|

| | | |
|--------------------------------|----------|-------|
| BRICKLAYER; MARBLE SETTER..... | \$ 41.48 | 18.63 |
|--------------------------------|----------|-------|

*The wage scale for prevailing wage projects performed in Blythe, China lake, Death Valley, Fort Irwin, Twenty-Nine Palms, Needles and 1-15 corridor (Barstow to the Nevada State Line) will be Three Dollars (\$3.00) above the standard San Bernardino/Riverside County hourly wage rate

BRCA0018-004 06/01/2022

| | Rates | Fringes |
|--|-------|---------|
|--|-------|---------|

| | | |
|----------------------|----------|-------|
| MARBLE FINISHER..... | \$ 37.87 | 14.13 |
| TILE FINISHER..... | \$ 32.44 | 12.54 |
| TILE LAYER..... | \$ 45.05 | 18.33 |

BRCA0018-010 09/01/2022

| | Rates | Fringes |
|--|-------|---------|
|--|-------|---------|

| | | |
|-----------------------------|----------|-------|
| TERRAZZO FINISHER..... | \$ 38.37 | 14.13 |
| TERRAZZO WORKER/SETTER..... | \$ 46.49 | 14.66 |

CARP0213-001 07/01/2021

CARPENTER

| | | |
|--|----------|-------|
| (1) Carpenter, Cabinet Installer, Insulation Installer, Hardwood Floor Worker and acoustical installer..... | \$ 51.60 | 16.28 |
| (2) Millwright..... | \$ 52.10 | 16.48 |
| (3) Piledrivermen/Derrick Bargeman, Bridge or Dock Carpenter, Heavy Framer, Rock Bargeman or Scowman, Rockslinger, Shingler (Commercial)..... | \$ 51.73 | 16.28 |
| (4) Pneumatic Nailer, Power Stapler..... | \$ 51.85 | 16.28 |
| (5) Sawfiler..... | \$ 51.69 | 16.28 |
| (6) Scaffold Builder..... | \$ 42.80 | 16.28 |
| (7) Table Power Saw Operator..... | \$ 51.70 | 16.28 |

FOOTNOTE: Work of forming in the construction of open cut sewers or storm drains, on operations in which horizontal lagging is used in conjunction with steel H-Beams driven or placed in pre- drilled holes, for that portion of a lagged trench against which concrete is poured, namely, as a substitute for back forms (which work is performed by piledrivers): \$0.13 per hour additional.

CARP0213-002 07/01/2021

| | Rates | Fringes |
|---------------------------|-----------|---------|
| Diver | | |
| (1) Wet..... | \$ 834.40 | 16.28 |
| (2) Standby..... | \$ 445.84 | 16.28 |
| (3) Tender..... | \$ 437.84 | 16.28 |
| (4) Assistant Tender..... | \$ 413.84 | 16.28 |

Amounts in "'Rates' column are per day

CARP0213-004 07/01/2021

| | Rates | Fringes |
|------------------------------|----------|---------|
| Drywall | | |
| DRYWALL INSTALLER/LATHER.... | \$ 51.60 | 16.28 |
| STOCKER/SCRAPPER..... | \$ 22.16 | 8.62 |

CARP0721-001 07/01/2021

| | Rates | Fringes |
|----------------------------------|----------|---------|
| Modular Furniture Installer..... | \$ 21.85 | 7.15 |

ELEC0440-001 01/01/2024

| | Rates | Fringes |
|---------------------------------------|----------|----------|
| ELECTRICIAN | | |
| INSIDE ELECTRICIAN..... | \$ 53.76 | 3%+27.50 |
| INTELLIGENT TRANSPORTATION SYSTEMS | | |
| Electrician..... | \$ 36.99 | 3%+23.18 |
| Technician..... | \$ 27.75 | 3%+23.18 |

ZONE PAY: Zone A: Free travel zone for all contractors performing work in Zone A.

Zone B: Any work performed in Zone (B) shall add \$12.00 per hour to the current wage scale. Zone (B) shall be the area from the eastern perimeter of Zone (A) to a line which runs north and south beginning at Little Morongo Canyon (San Bernardino/Riverside County Line), Southeast along the Coachella Tunnels, Colorado River Aqueduct and Mecca Tunnels to Pinkham Wash then South to Box Canyon Road, then southwest along Box Canyon Road to Highway 195 west onto 195 south to Highway 86 to Riverside/Imperial County Line.

 ELEC1245-001 06/01/2022

| | Rates | Fringes |
|--|----------|---------|
| LINE CONSTRUCTION | | |
| (1) Lineman; Cable splicer.. | \$ 64.40 | 22.58 |
| (2) Equipment specialist (operates crawler tractors, commercial motor vehicles, backhoes, trenchers, cranes (50 tons and below), overhead & underground distribution line equipment)..... | \$ 50.00 | 21.30 |
| (3) Groundman..... | \$ 38.23 | 20.89 |
| (4) Powderman..... | \$ 51.87 | 18.79 |

HOLIDAYS: New Year's Day, M.L. King Day, Memorial Day, Independence Day, Labor Day, Veterans Day, Thanksgiving Day and day after Thanksgiving, Christmas Day

 ELEV0018-001 01/01/2024

| | Rates | Fringes |
|------------------------|----------|------------|
| ELEVATOR MECHANIC..... | \$ 66.63 | 37.885+a+b |

FOOTNOTE:
 a. PAID VACATION: Employer contributes 8% of regular hourly rate as vacation pay credit for employees with more than 5 years of service, and 6% for 6 months to 5 years of service.
 b. PAID HOLIDAYS: New Year's Day, Memorial Day, Independence Day, Labor Day, Veterans' Day, Thanksgiving Day, Friday after Thanksgiving, and Christmas Day.

 ENGI0012-004 08/01/2023

| | Rates | Fringes |
|---|----------|---------|
| OPERATOR: Power Equipment (DREDGING) | | |
| (1) Leverman..... | \$ 64.10 | 34.60 |
| (2) Dredge dozer..... | \$ 58.13 | 34.60 |
| (3) Deckmate..... | \$ 58.02 | 34.60 |
| (4) Winch operator (stern winch on dredge)..... | \$ 57.47 | 34.60 |
| (5) Fireman-Oiler, Deckhand, Bargeman, Leveehand..... | \$ 56.93 | 34.60 |
| (6) Barge Mate..... | \$ 57.54 | 34.60 |

 ENGI0012-024 07/01/2023

| | Rates | Fringes |
|---------------------------|-------|---------|
| OPERATOR: Power Equipment | | |

(All Other Work)

| | | |
|---------------|----------|-------|
| GROUP 1..... | \$ 53.90 | 32.80 |
| GROUP 2..... | \$ 54.68 | 32.80 |
| GROUP 3..... | \$ 54.97 | 32.80 |
| GROUP 4..... | \$ 56.46 | 32.80 |
| GROUP 6..... | \$ 56.68 | 32.80 |
| GROUP 8..... | \$ 56.79 | 32.80 |
| GROUP 10..... | \$ 56.91 | 32.80 |
| GROUP 12..... | \$ 57.08 | 32.80 |
| GROUP 13..... | \$ 57.18 | 32.80 |
| GROUP 14..... | \$ 57.21 | 32.80 |
| GROUP 15..... | \$ 57.29 | 32.80 |
| GROUP 16..... | \$ 57.41 | 32.80 |
| GROUP 17..... | \$ 57.58 | 32.80 |
| GROUP 18..... | \$ 57.68 | 32.80 |
| GROUP 19..... | \$ 57.79 | 32.80 |
| GROUP 20..... | \$ 57.91 | 32.80 |
| GROUP 21..... | \$ 58.08 | 32.80 |
| GROUP 22..... | \$ 58.18 | 32.80 |
| GROUP 23..... | \$ 58.29 | 32.80 |
| GROUP 24..... | \$ 58.41 | 32.80 |
| GROUP 25..... | \$ 58.58 | 32.80 |

OPERATOR: Power Equipment
(Cranes, Piledriving & Hoisting)

| | | |
|---------------|----------|-------|
| GROUP 1..... | \$ 55.25 | 32.80 |
| GROUP 2..... | \$ 56.03 | 32.80 |
| GROUP 3..... | \$ 56.32 | 32.80 |
| GROUP 4..... | \$ 56.46 | 32.80 |
| GROUP 5..... | \$ 56.68 | 32.80 |
| GROUP 6..... | \$ 56.79 | 32.80 |
| GROUP 7..... | \$ 56.91 | 32.80 |
| GROUP 8..... | \$ 57.08 | 32.80 |
| GROUP 9..... | \$ 57.25 | 32.80 |
| GROUP 10..... | \$ 58.25 | 32.80 |
| GROUP 11..... | \$ 59.25 | 32.80 |
| GROUP 12..... | \$ 60.25 | 32.80 |
| GROUP 13..... | \$ 61.25 | 32.80 |

OPERATOR: Power Equipment
(Tunnel Work)

| | | |
|--------------|----------|-------|
| GROUP 1..... | \$ 55.75 | 32.80 |
| GROUP 2..... | \$ 56.53 | 32.80 |
| GROUP 3..... | \$ 56.82 | 32.80 |
| GROUP 4..... | \$ 56.96 | 32.80 |
| GROUP 5..... | \$ 57.18 | 32.80 |
| GROUP 6..... | \$ 57.29 | 32.80 |
| GROUP 7..... | \$ 57.41 | 32.80 |

PREMIUM PAY:

\$10.00 per hour shall be paid on all Power Equipment Operator work on the following Military Bases: China Lake Naval Reserve, Vandenberg AFB, Point Arguello, Seely Naval Base, Fort Irwin, Nebo Annex Marine Base, Marine Corp Logistics Base Yermo, Edwards AFB, 29 Palms Marine Base and Camp Pendleton

Workers required to suit up and work in a hazardous material environment: \$2.00 per hour additional. Combination mixer and compressor operator on gunite work shall be classified as a concrete mobile mixer operator.

SEE ZONE DEFINITIONS AFTER CLASSIFICATIONS

POWER EQUIPMENT OPERATORS CLASSIFICATIONS

GROUP 1: Bargeman; Brakeman; Compressor operator; Ditch Witch, with seat or similar type equipment; Elevator operator-inside; Engineer Oiler; Forklift operator (includes loed, lull or similar types under 5 tons; Generator operator; Generator, pump or compressor plant

operator; Pump operator; Signalman; Switchman

GROUP 2: Asphalt-rubber plant operator (nurse tank operator);Coil Tubing Rig Operator, Concrete mixer operator-skip type; Conveyor operator; Fireman; Forklift operator (includes loed, lull or similar types over 5 tons; Hydrostatic pump operator; oiler crusher (asphalt or concrete plant); Petromat laydown machine; PJU side dum jack; Screening and conveyor machine operator (or similar types); Skiploader (wheel type up to 3/4 yd. without attachment); Tar pot fireman; Temporary heating plant operator; Trenching machine oiler

GROUP 3: Asphalt-rubber blend operator; Bobcat or similar type (Skid steer); Equipment greaser (rack); Ford Ferguson (with dragtype attachments); Helicopter radioman (ground); Stationary pipe wrapping and cleaning machine operator

GROUP 4: Asphalt plant fireman; Backhoe operator (mini-max or similar type); Boring machine operator; Boxman or mixerman (asphalt or concrete); Chip spreading machine operator; Concrete cleaning decontamination machine operator; Concrete Pump Operator (small portable);Direct Push Operator (Geoprobe or similar types) Drilling machine operator, small auger types (Texoma super economatic or similar types - Hughes 100 or 200 or similar types - drilling depth of 30' maximum); Equipment greaser (grease truck); Guard rail post driver operator; Highline cableway signalman; Hydra-hammer-aero stomper; Micro Tunneling (above ground tunnel); Power concrete curing machine operator; Power concrete saw operator; Power-driven jumbo form setter operator; Power sweeper operator; Rock Wheel Saw/Trencher; Roller operator (compacting); Screed operator (asphalt or concrete); Trenching machine operator (up to 6 ft.); Vacuum or much truck

GROUP 6: Articulating material hauler; Asphalt plant engineer; Batch plant operator; Bit sharpener; Concrete joint machine operator (canal and similar type); Concrete planer operator; Dandy digger; Deck engine operator; Derrickman (oilfield type); Drilling machine operator, bucket or auger types (Calweld 100 bucket or similar types - Watson 1000 auger or similar types - Texoma 330, 500 or 600 auger or similar types - drilling depth of 45' maximum); Drilling machine operator; Hydrographic seeder machine operator (straw, pulp or seed), Jackson track maintainer, or similar type; Kalamazoo Switch tamper, or similar type; Machine tool operator; Maginnis internal full slab vibrator, Mechanical berm, curb or gutter(concrete or asphalt); Mechanical finisher operator (concrete, Clary-Johnson-Bidwell or similar); Micro tunnel system (below ground); Pavement breaker operator (truck mounted); Road oil mixing machine operator; Roller operator (asphalt or finish), rubber-tired earth moving equipment (single engine, up to and including 25 yds. struck); Self-propelled tar pipelining machine operator; Skiploader operator (crawler and wheel type, over 3/4 yd. and up to and including 1-1/2 yds.); Slip form pump operator (power driven hydraulic lifting device for concrete forms); Tractor operator-bulldozer, tamper-scraper (single engine, up to 100 h.p. flywheel and similar types, up to and including D-5 and similar types); Tugger hoist operator (1 drum); Ultra high pressure waterjet cutting tool system operator; Vacuum blasting machine operator

GROUP 8: Asphalt or concrete spreading operator (tamping or finishing); Asphalt paving machine operator (Barber Greene or similar type); Asphalt-rubber distribution operator; Backhoe operator (up to and including 3/4 yd.), small ford,

Case or similar types; Cable Bundling Machine Operator (excluding handheld); Cable Trenching Machine Operator (Spider Plow or similar types) Cast-in-place pipe laying machine operator; Combination mixer and compressor operator (gunite work); Compactor operator (self-propelled); Concrete mixer operator (paving); Crushing plant operator; Drill Doctor; Drilling machine operator, Bucket or auger types (Calweld 150 bucket or similar types - Watson 1500, 2000 2500 auger or similar types - Texoma 700, 800 auger or similar types - drilling depth of 60' maximum); Elevating grader operator; Grade checker; Gradall operator; Grouting machine operator; Heavy-duty repairman; Heavy equipment robotics operator; Kalamazoo balliste regulator or similar type; Kolman belt loader and similar type; Le Tourneau blob compactor or similar type; Loader operator (Athey, Euclid, Sierra and similar types); Mobark Chipper or similar; Ozzie padder or similar types; P.C. slot saw; Pneumatic concrete placing machine operator (Hackley-Presswell or similar type); Pumpcrete gun operator; RCM Cementing Unit Operator, Rail/Switch Grinder Operator (Harsco or similar types) Rock Drill or similar types; Rotary drill operator (excluding caisson type); Rubber-tired earth-moving equipment operator (single engine, caterpillar, Euclid, Athey Wagon and similar types with any and all attachments over 25 yds. up to and including 50 cu. yds. struck); Rubber-tired earth-moving equipment operator (multiple engine up to and including 25 yds. struck); Rubber-tired scraper operator (self-loading paddle wheel type-John Deere, 1040 and similar single unit); Self-propelled curb and gutter machine operator; Shuttle buggy; Skiploader operator (crawler and wheel type over 1-1/2 yds. up to and including 6-1/2 yds.); Soil remediation plant operator; Surface heaters and planer operator; Tractor compressor drill combination operator; Tractor operator (any type larger than D-5 - 100 flywheel h.p. and over, or similar-bulldozer, tamper, scraper and push tractor single engine); Tractor operator (boom attachments), Traveling pipe wrapping, cleaning and bending machine operator; Trenching machine operator (over 6 ft. depth capacity, manufacturer's rating); trenching Machine with Road Miner attachment (over 6 ft depth capacity): Ultra high pressure waterjet cutting tool system mechanic; Water pull (compaction) operator

GROUP 10: Drilling machine operator, Bucket or auger types (Calweld 200 B bucket or similar types-Watson 3000 or 5000 auger or similar types-Texoma 900 auger or similar types-drilling depth of 105' maximum); Dual drum mixer, dynamic compactor LDC350 (or similar types); Monorail locomotive operator (diesel, gas or electric); Motor patrol-blade operator (single engine); Multiple engine tractor operator (Euclid and similar type-except Quad 9 cat.); Rubber-tired earth-moving equipment operator (single engine, over 50 yds. struck); Pneumatic pipe ramming tool and similar types; Prestressed wrapping machine operator; Rubber-tired earth-moving equipment operator (single engine, over 50 yds. struck); Rubber tired earth moving equipment operator (multiple engine, Euclid, caterpillar and similar over 25 yds. and up to 50 yds. struck), Tower crane repairman; Tractor loader operator (crawler and wheel type over 6-1/2 yds.); Woods mixer operator (and similar Pugmill equipment)

GROUP 12: Auto grader operator; Automatic slip form operator; Drilling machine operator, bucket or auger types (Calweld, auger 200 CA or similar types - Watson, auger 6000 or similar types - Hughes Super Duty, auger 200 or similar types - drilling depth of 175' maximum); Hoe ram or similar with compressor; Mass excavator operator less tha 750 cu. yards; Mechanical finishing machine operator; Mobile form

traveler operator; Motor patrol operator (multi-engine); Pipe mobile machine operator; Rubber-tired earth-moving equipment operator (multiple engine, Euclid, Caterpillar and similar type, over 50 cu. yds. struck); Rubber-tired self-loading scraper operator (paddle-wheel-auger type self-loading - two (2) or more units)

GROUP 13: Rubber-tired earth-moving equipment operator operating equipment with push-pull system (single engine, up to and including 25 yds. struck)

GROUP 14: Canal liner operator; Canal trimmer operator; Remote-control earth-moving equipment operator (operating a second piece of equipment: \$1.00 per hour additional); Wheel excavator operator (over 750 cu. yds.)

GROUP 15: Rubber-tired earth-moving equipment operator, operating equipment with push-pull system (single engine, Caterpillar, Euclid, Athey Wagon and similar types with any and all attachments over 25 yds. and up to and including 50 yds. struck); Rubber-tired earth-moving equipment operator, operating equipment with push-pull system (multiple engine-up to and including 25 yds. struck)

GROUP 16: Rubber-tired earth-moving equipment operator, operating equipment with push-pull system (single engine, over 50 yds. struck); Rubber-tired earth-moving equipment operator, operating equipment with push-pull system (multiple engine, Euclid, Caterpillar and similar, over 25 yds. and up to 50 yds. struck)

GROUP 17: Rubber-tired earth-moving equipment operator, operating equipment with push-pull system (multiple engine, Euclid, Caterpillar and similar, over 50 cu. yds. struck); Tandem tractor operator (operating crawler type tractors in tandem - Quad 9 and similar type)

GROUP 18: Rubber-tired earth-moving equipment operator, operating in tandem (scrapers, belly dumps and similar types in any combination, excluding compaction units - single engine, up to and including 25 yds. struck)

GROUP 19: Rotex concrete belt operator (or similar types); Rubber-tired earth-moving equipment operator, operating in tandem (scrapers, belly dumps and similar types in any combination, excluding compaction units - single engine, Caterpillar, Euclid, Athey Wagon and similar types with any and all attachments over 25 yds. and up to and including 50 cu. yds. struck); Rubber-tired earth-moving equipment operator, operating in tandem (scrapers, belly dumps and similar types in any combination, excluding compaction units - multiple engine, up to and including 25 yds. struck)

GROUP 20: Rubber-tired earth-moving equipment operator, operating in tandem (scrapers, belly dumps and similar types in any combination, excluding compaction units - single engine, over 50 yds. struck); Rubber-tired earth-moving equipment operator, operating in tandem (scrapers, belly dumps, and similar types in any combination, excluding compaction units - multiple engine, Euclid, Caterpillar and similar, over 25 yds. and up to 50 yds. struck)

GROUP 21: Rubber-tired earth-moving equipment operator, operating in tandem (scrapers, belly dumps and similar types in any combination, excluding compaction units - multiple engine, Euclid, Caterpillar and similar type, over 50 cu. yds. struck)

GROUP 22: Rubber-tired earth-moving equipment operator,

operating equipment with the tandem push-pull system (single engine, up to and including 25 yds. struck)

GROUP 23: Rubber-tired earth-moving equipment operator, operating equipment with the tandem push-pull system (single engine, Caterpillar, Euclid, Athey Wagon and similar types with any and all attachments over 25 yds. and up to and including 50 yds. struck); Rubber-tired earth-moving equipment operator, operating with the tandem push-pull system (multiple engine, up to and including 25 yds. struck)

GROUP 24: Rubber-tired earth-moving equipment operator, operating equipment with the tandem push-pull system (single engine, over 50 yds. struck); Rubber-tired earth-moving equipment operator, operating equipment with the tandem push-pull system (multiple engine, Euclid, Caterpillar and similar, over 25 yds. and up to 50 yds. struck)

GROUP 25: Concrete pump operator-truck mounted; Rubber-tired earth-moving equipment operator, operating equipment with the tandem push-pull system (multiple engine, Euclid, Caterpillar and similar type, over 50 cu. yds. struck); Spyder Excavator Operator, with all attachments

CRANES, PILEDIVING AND HOISTING EQUIPMENT CLASSIFICATIONS

GROUP 1: Engineer oiler; Fork lift operator (includes loed, lull or similar types)

GROUP 2: Truck crane oiler

GROUP 3: A-frame or winch truck operator; Ross carrier operator (jobsite)

GROUP 4: Bridge-type unloader and turntable operator; Helicopter hoist operator

GROUP 5: Hydraulic boom truck; Stinger crane (Austin-Western or similar type); Tugger hoist operator (1 drum)

GROUP 6: Bridge crane operator; Creter crane operator; Hoist operator (Chicago boom and similar type); Lift mobile operator; Lift slab machine operator (Vagtborg and similar types); Material hoist and/or manlift operator; Polar gantry crane operator; Self Climbing scaffold (or similar type); Shovel, backhoe, dragline, clamshell operator (over 3/4 yd. and up to 5 cu. yds. mrc); Tugger hoist operator

GROUP 7: Pedestal crane operator; Shovel, backhoe, dragline, clamshell operator (over 5 cu. yds. mrc); Tower crane repair; Tugger hoist operator (3 drum)

GROUP 8: Crane operator (up to and including 25 ton capacity); Crawler transporter operator; Derrick barge operator (up to and including 25 ton capacity); Hoist operator, stiff legs, Guy derrick or similar type (up to and including 25 ton capacity); Shovel, backhoe, dragline, clamshell operator (over 7 cu. yds., M.R.C.)

GROUP 9: Crane operator (over 25 tons and up to and including 50 tons mrc); Derrick barge operator (over 25 tons up to and including 50 tons mrc); Highline cableway operator; Hoist operator, stiff legs, Guy derrick or similar type (over 25 tons up to and including 50 tons mrc); K-crane operator; Polar crane operator; Self erecting tower crane operator maximum lifting capacity ten tons

GROUP 10: Crane operator (over 50 tons and up to and

including 100 tons mrc); Derrick barge operator (over 50 tons up to and including 100 tons mrc); Hoist operator, stiff legs, Guy derrick or similar type (over 50 tons up to and including 100 tons mrc), Mobile tower crane operator (over 50 tons, up to and including 100 tons M.R.C.);

GROUP 11: Crane operator (over 100 tons and up to and including 200 tons mrc); Derrick barge operator (over 100 tons up to and including 200 tons mrc); Hoist operator, stiff legs, Guy derrick or similar type (over 100 tons up to and including 200 tons mrc); Mobile tower crane operator (over 100 tons up to and including 200 tons mrc) ; Tower crane operator and tower gantry

GROUP 12: Crane operator (over 200 tons up to and including 300 tons mrc); Derrick barge operator (over 200 tons up to and including 300 tons mrc); Hoist operator, stiff legs, Guy derrick or similar type (over 200 tons, up to and including 300 tons mrc); Mobile tower crane operator (over 200 tons, up to and including 300 tons mrc)

GROUP 13: Crane operator (over 300 tons); Derrick barge operator (over 300 tons); Helicopter pilot; Hoist operator, stiff legs, Guy derrick or similar type (over 300 tons); Mobile tower crane operator (over 300 tons)

TUNNEL CLASSIFICATIONS

GROUP 1: Skiploader (wheel type up to 3/4 yd. without attachment)

GROUP 2: Power-driven jumbo form setter operator

GROUP 3: Dinkey locomotive or motorperson (up to and including 10 tons)

GROUP 4: Bit sharpener; Equipment greaser (grease truck); Slip form pump operator (power-driven hydraulic lifting device for concrete forms); Tugger hoist operator (1 drum); Tunnel locomotive operator (over 10 and up to and including 30 tons)

GROUP 5: Backhoe operator (up to and including 3/4 yd.); Small Ford, Case or similar; Drill doctor; Grouting machine operator; Heading shield operator; Heavy-duty repairperson; Loader operator (Athey, Euclid, Sierra and similar types); Mucking machine operator (1/4 yd., rubber-tired, rail or track type); Pneumatic concrete placing machine operator (Hackley-Presswell or similar type); Pneumatic heading shield (tunnel); Pumpcrete gun operator; Tractor compressor drill combination operator; Tugger hoist operator (2 drum); Tunnel locomotive operator (over 30 tons)

GROUP 6: Heavy Duty Repairman

GROUP 7: Tunnel mole boring machine operator

ENGINEERS ZONES

\$1.00 additional per hour for all of IMPERIAL County and the portions of KERN, RIVERSIDE & SAN BERNARDINO Counties as defined below:

That area within the following Boundary: Begin in San Bernardino County, approximately 3 miles NE of the intersection of I-15 and the California State line at that point which is the NW corner of Section 1, T17N,m R14E, San Bernardino Meridian. Continue W in a straight line to that point which is the SW corner of the northwest quarter of Section 6, T27S, R42E, Mt. Diablo Meridian. Continue North to the intersection

with the Inyo County Boundary at that point which is the NE corner of the western half of the northern quarter of Section 6, T25S, R42E, MDM. Continue W along the Inyo and San Bernardino County boundary until the intersection with Kern County, as that point which is the SE corner of Section 34, T24S, R40E, MDM. Continue W along the Inyo and Kern County boundary until the intersection with Tulare County, at that point which is the SW corner of the SE quarter of Section 32, T24S, R37E, MDM. Continue W along the Kern and Tulare County boundary, until that point which is the NW corner of T25S, R32E, MDM. Continue S following R32E lines to the NW corner of T31S, R32E, MDM. Continue W to the NW corner of T31S, R31E, MDM. Continue S to the SW corner of T32S, R31E, MDM. Continue W to SW corner of SE quarter of Section 34, T32S, R30E, MDM. Continue S to SW corner of T11N, R17W, SBM. Continue E along south boundary of T11N, SBM to SW corner of T11N, R7W, SBM. Continue S to SW corner of T9N, R7W, SBM. Continue E along south boundary of T9N, SBM to SW corner of T9N, R1E, SBM. Continue S along west boundary of R1E, SMB to Riverside County line at the SW corner of T1S, R1E, SBM. Continue E along south boundary of T1s, SBM (Riverside County Line) to SW corner of T1S, R10E, SBM. Continue S along west boundary of R10E, SBM to Imperial County line at the SW corner of T8S, R10E, SBM. Continue W along Imperial and Riverside county line to NW corner of T9S, R9E, SBM. Continue S along the boundary between Imperial and San Diego Counties, along the west edge of R9E, SBM to the south boundary of Imperial County/California state line. Follow the California state line west to Arizona state line, then north to Nevada state line, then continuing NW back to start at the point which is the NW corner of Section 1, T17N, R14E, SBM

\$1.00 additional per hour for portions of SAN LUIS OBISPO, KERN, SANTA BARBARA & VENTURA as defined below:

That area within the following Boundary: Begin approximately 5 miles north of the community of Cholame, on the Monterey County and San Luis Obispo County boundary at the NW corner of T25S, R16E, Mt. Diablo Meridian. Continue south along the west side of R16E to the SW corner of T30S, R16E, MDM. Continue E to SW corner of T30S, R17E, MDM. Continue S to SW corner of T31S, R17E, MDM. Continue E to SW corner of T31S, R18E, MDM. Continue S along West side of R18E, MDM as it crosses into San Bernardino Meridian numbering area and becomes R30W. Follow the west side of R30W, SBM to the SW corner of T9N, R30W, SBM. Continue E along the south edge of T9N, SBM to the Santa Barbara County and Ventura County boundary at that point which is the SW corner of Section 34. T9N, R24W, SBM, continue S along the Ventura County line to that point which is the SW corner of the SE quarter of Section 32, T7N, R24W, SBM. Continue E along the south edge of T7N, SBM to the SE corner to T7N, R21W, SBM. Continue N along East side of R21W, SBM to Ventura County and Kern County boundary at the NE corner of T8N, R21W. Continue W along the Ventura County and Kern County boundary to the SE corner of T9N, R21W. Continue North along the East edge of R21W, SBM to the NE corner of T12N, R21W, SBM. Continue West along the north edge of T12N, SBM to the SE corner of T32S, R21E, MDM. [T12N SBM is a think strip between T11N SBM and T32S MDM]. Continue North along the East side of R21E, MDM to the Kings County and Kern County border at the NE corner of T25S, R21E, MDM, continue West along the Kings County and Kern County Boundary until the intersection of San Luis Obispo County. Continue west along the Kings County and San Luis Obispo County boundary until the intersection with Monterey County. Continue West along the Monterey County and San Luis Obispo County boundary to the beginning point at the NW corner of T25S, R16E, MDM.

\$2.00 additional per hour for INYO and MONO Counties and the

Northern portion of SAN BERNARDINO County as defined below:

That area within the following Boundary: Begin at the intersection of the northern boundary of Mono County and the California state line at the point which is the center of Section 17, T10N, R22E, Mt. Diablo Meridian. Continue S then SE along the entire western boundary of Mono County, until it reaches Inyo County at the point which is the NE corner of the Western half of the NW quarter of Section 2, T8S, R29E, MDM. Continue SSE along the entire western boundary of Inyo County, until the intersection with Kern County at the point which is the SW corner of the SE 1/4 of Section 32, T24S, R37E, MDM. Continue E along the Inyo and Kern County boundary until the intersection with San Bernardino County at that point which is the SE corner of section 34, T24S, R40E, MDM. Continue E along the Inyo and San Bernardino County boundary until the point which is the NE corner of the Western half of the NW quarter of Section 6, T25S, R42E, MDM. Continue S to that point which is the SW corner of the NW quarter of Section 6, T27S, R42E, MDM. Continue E in a straight line to the California and Nevada state border at the point which is the NW corner of Section 1, T17N, R14E, San Bernardino Meridian. Then continue NW along the state line to the starting point, which is the center of Section 18, T10N, R22E, MDM.

REMAINING AREA NOT DEFINED ABOVE RECIEVES BASE RATE

IRON0433-006 01/01/2024

| | Rates | Fringes |
|--|----------|---------|
| IRONWORKER | | |
| Fence Erector..... | \$ 42.53 | 26.26 |
| Ornamental, Reinforcing and Structural..... | \$ 47.45 | 34.90 |

PREMIUM PAY:

\$9.00 additional per hour at the following locations:

China Lake Naval Test Station, Chocolate Mountains Naval Reserve-Niland, Edwards AFB, Fort Irwin Military Station, Fort Irwin Training Center-Goldstone, San Clemente Island, San Nicholas Island, Susanville Federal Prison, 29 Palms - Marine Corps, U.S. Marine Base - Barstow, U.S. Naval Air Facility - Sealey, Vandenberg AFB Army Defense Language Institute - Monterey, Fallon Air Base, Naval Post Graduate School - Monterey, Yermo Marine Corps Logistics Center
Port Hueneme, Port Mugu, U.S. Coast Guard Station - Two Rock

LAB00300-005 08/01/2022

| | Rates | Fringes |
|-------------------------------|----------|---------|
| Asbestos Removal Laborer..... | \$ 39.23 | 23.28 |

SCOPE OF WORK: Includes site mobilization, initial site cleanup, site preparation, removal of asbestos-containing material and toxic waste, encapsulation, enclosure and disposal of asbestos- containing materials and toxic waste by hand or with equipment or machinery; scaffolding, fabrication of temporary wooden barriers and assembly of decontamination stations.

| | Rates | Fringes |
|------------------|----------|---------|
| LABORER (GUNITE) | | |
| GROUP 1..... | \$ 48.50 | 21.37 |
| GROUP 2..... | \$ 47.55 | 21.37 |
| GROUP 3..... | \$ 44.01 | 21.37 |

FOOTNOTE: GUNITE PREMIUM PAY: Workers working from a Bosn'n's Chair or suspended from a rope or cable shall receive 40 cents per hour above the foregoing applicable classification rates. Workers doing gunite and/or shotcrete work in a tunnel shall receive 35 cents per hour above the foregoing applicable classification rates, paid on a portal-to-portal basis. Any work performed on, in or above any smoke stack, silo, storage elevator or similar type of structure, when such structure is in excess of 75'-0"" above base level and which work must be performed in whole or in part more than 75'-0"" above base level, that work performed above the 75'-0"" level shall be compensated for at 35 cents per hour above the applicable classification wage rate.

GUNITE LABORER CLASSIFICATIONS

- GROUP 1: Rodmen, Nozzlemen
- GROUP 2: Gunmen
- GROUP 3: Reboundmen

| | Rates | Fringes |
|--|----------|---------|
| Laborers: (HORIZONTAL DIRECTIONAL DRILLING) | | |
| (1) Drilling Crew Laborer... | \$ 40.69 | 18.25 |
| (2) Vehicle Operator/Hauler. | \$ 40.86 | 18.25 |
| (3) Horizontal Directional Drill Operator..... | \$ 42.71 | 18.25 |
| (4) Electronic Tracking Locator..... | \$ 44.71 | 18.25 |
| Laborers: (STRIPING/SLURRY SEAL) | | |
| GROUP 1..... | \$ 41.90 | 21.32 |
| GROUP 2..... | \$ 43.20 | 21.32 |
| GROUP 3..... | \$ 45.21 | 21.32 |
| GROUP 4..... | \$ 46.95 | 21.32 |

LABORERS - STRIPING CLASSIFICATIONS

GROUP 1: Protective coating, pavement sealing, including repair and filling of cracks by any method on any surface in parking lots, game courts and playgrounds; carstops; operation of all related machinery and equipment; equipment repair technician

GROUP 2: Traffic surface abrasive blaster; pot tender - removal of all traffic lines and markings by any method (sandblasting, waterblasting, grinding, etc.) and preparation of surface for coatings. Traffic control person: controlling and directing traffic through both conventional and moving lane closures; operation of all related machinery and equipment

GROUP 3: Traffic delineating device applicator: Layout and application of pavement markers, delineating signs, rumble

and traffic bars, adhesives, guide markers, other traffic delineating devices including traffic control. This category includes all traffic related surface preparation (sandblasting, waterblasting, grinding) as part of the application process. Traffic protective delineating system installer: removes, relocates, installs, permanently affixed roadside and parking delineation barricades, fencing, cable anchor, guard rail, reference signs, monument markers; operation of all related machinery and equipment; power broom sweeper

GROUP 4: Striper: layout and application of traffic stripes and markings; hot thermo plastic; tape traffic stripes and markings, including traffic control; operation of all related machinery and equipment

LABO1184-002 07/01/2022

Rates Fringes

LABORER (TUNNEL)

| | | |
|--------------|----------|-------|
| GROUP 1..... | \$ 45.68 | 23.30 |
| GROUP 2..... | \$ 46.00 | 23.30 |
| GROUP 3..... | \$ 46.46 | 23.30 |
| GROUP 4..... | \$ 47.15 | 23.30 |

LABORER

| | | |
|--------------|----------|-------|
| GROUP 1..... | \$ 36.39 | 21.04 |
| GROUP 2..... | \$ 36.94 | 21.04 |
| GROUP 3..... | \$ 37.49 | 21.04 |
| GROUP 4..... | \$ 39.04 | 21.04 |
| GROUP 5..... | \$ 39.39 | 21.04 |

LABORER CLASSIFICATIONS

GROUP 1: Cleaning and handling of panel forms; Concrete screeding for rough strike-off; Concrete, water curing; Demolition laborer, the cleaning of brick if performed by a worker performing any other phase of demolition work, and the cleaning of lumber; Fire watcher, limber, brush loader, piler and debris handler; Flag person; Gas, oil and/or water pipeline laborer; Laborer, asphalt-rubber material loader; Laborer, general or construction; Laborer, general clean-up; Laborer, landscaping; Laborer, jetting; Laborer, temporary water and air lines; Material hose operator (walls, slabs, floors and decks); Plugging, filling of shee bolt holes; Dry packing of concrete; Railroad maintenance, repair track person and road beds; Streetcar and railroad construction track laborers; Rigging and signaling; Scaler; Slip form raiser; Tar and mortar; Tool crib or tool house laborer; Traffic control by any method; Window cleaner; Wire mesh pulling - all concrete pouring operations

GROUP 2: Asphalt shoveler; Cement dumper (on 1 yd. or larger mixer and handling bulk cement); Cesspool digger and installer; Chucktender; Chute handler, pouring concrete, the handling of the chute from readymix trucks, such as walls, slabs, decks, floors, foundation, footings, curbs, gutters and sidewalks; Concrete curer, impervious membrane and form oiler; Cutting torch operator (demolition); Fine grader, highways and street paving, airport, runways and similar type heavy construction; Gas, oil and/or water pipeline wrapper - pot tender and form person; Guinea chaser; Headerboard person - asphalt; Laborer, packing rod steel and pans; Membrane vapor barrier installer; Power broom sweeper (small); Riprap stonepaver, placing stone or wet sacked concrete; Roto scraper and tiller; Sandblaster (pot tender); Septic tank digger and installer(lead); Tank scaler and cleaner; Tree climber, faller, chain saw operator, Pittsburgh chipper and similar type brush

Shredder; Underground laborer, including caisson bellower

GROUP 3: Buggymobile person; Concrete cutting torch; Concrete pile cutter; Driller, jackhammer, 2-1/2 ft. drill steel or longer; Dri-pak-it machine; Gas, oil and/or water pipeline wrapper, 6-in. pipe and over, by any method, inside and out; High scaler (including drilling of same); Hydro seeder and similar type; Impact wrench multi-plate; Kettle person, pot person and workers applying asphalt, lay-kold, creosote, lime caustic and similar type materials ("applying" means applying, dipping, brushing or handling of such materials for pipe wrapping and waterproofing); Operator of pneumatic, gas, electric tools, vibrating machine, pavement breaker, air blasting, come-alongs, and similar mechanical tools not separately classified herein; Pipelayer's backup person, coating, grouting, making of joints, sealing, caulking, diapering and including rubber gasket joints, pointing and any and all other services; Rock slinger; Rotary scarifier or multiple head concrete chipping scarifier; Steel headerboard and guideline setter; Tamper, Barko, Wacker and similar type; Trenching machine, hand-propelled

GROUP 4: Asphalt raker, lute person, ironer, asphalt dump person, and asphalt spreader boxes (all types); Concrete core cutter (walls, floors or ceilings), grinder or sander; Concrete saw person, cutting walls or flat work, scoring old or new concrete; Cribber, shorer, lagging, sheeting and trench bracing, hand-guided lagging hammer; Head rock slinger; Laborer, asphalt- rubber distributor boot person; Laser beam in connection with laborers' work; Oversize concrete vibrator operator, 70 lbs. and over; Pipelayer performing all services in the laying and installation of pipe from the point of receiving pipe in the ditch until completion of operation, including any and all forms of tubular material, whether pipe, metallic or non-metallic, conduit and any other stationary type of tubular device used for the conveying of any substance or element, whether water, sewage, solid gas, air, or other product whatsoever and without regard to the nature of material from which the tubular material is fabricated; No-joint pipe and stripping of same; Prefabricated manhole installer; Sandblaster (nozzle person), water blasting, Porta Shot-Blast

GROUP 5: Blaster powder, all work of loading holes, placing and blasting of all powder and explosives of whatever type, regardless of method used for such loading and placing; Driller: All power drills, excluding jackhammer, whether core, diamond, wagon, track, multiple unit, and any and all other types of mechanical drills without regard to the form of motive power; Toxic waste removal

TUNNEL LABORER CLASSIFICATIONS

GROUP 1: Batch plant laborer; Changehouse person; Dump person; Dump person (outside); Swamper (brake person and switch person on tunnel work); Tunnel materials handling person; Nipper; Pot tender, using mastic or other materials (for example, but not by way of limitation, shotcrete, etc.)

GROUP 2: Chucktender, cabletender; Loading and unloading agitator cars; Vibrator person, jack hammer, pneumatic tools (except driller); Bull gang mucker, track person; Concrete crew, including rodder and spreader

GROUP 3: Blaster, driller, powder person; Chemical grout jet person; Cherry picker person; Grout gun person; Grout mixer person; Grout pump person; Jackleg miner; Jumbo person; Kemper and other pneumatic concrete placer operator; Miner, tunnel (hand or machine); Nozzle person; Operating of

troweling and/or grouting machines; Powder person (primer house); Primer person; Sandblaster; Shotcrete person; Steel form raiser and setter; Timber person, retimber person, wood or steel; Tunnel Concrete finisher

GROUP 4: Diamond driller; Sandblaster; Shaft and raise work

LAB01184-004 07/01/2022

| | Rates | Fringes |
|-------------------|----------|---------|
| Brick Tender..... | \$ 37.32 | 21.45 |

LAB01414-001 08/03/2022

| | Rates | Fringes |
|------------------------------|----------|---------|
| LABORER | | |
| PLASTER CLEAN-UP LABORER.... | \$ 38.92 | 23.32 |
| PLASTER TENDER..... | \$ 41.47 | 23.32 |

Work on a swing stage scaffold: \$1.00 per hour additional.

PAIN0036-001 07/01/2023

| | Rates | Fringes |
|--|----------|---------|
| Painters: (Including Lead Abatement) | | |
| (1) Repaint (excludes San Diego County)..... | \$ 29.59 | 17.12 |
| (2) All Other Work..... | \$ 38.52 | 18.64 |

REPAINT of any previously painted structure. Exceptions: work involving the aerospace industry, breweries, commercial recreational facilities, hotels which operate commercial establishments as part of hotel service, and sports facilities.

PAIN0036-008 09/01/2022

| | Rates | Fringes |
|-----------------------------|----------|---------|
| DRYWALL FINISHER/TAPER..... | \$ 46.28 | 23.52 |

PAIN0036-015 01/01/2020

| | Rates | Fringes |
|--------------|----------|---------|
| GLAZIER..... | \$ 43.45 | 23.39 |

FOOTNOTE: Additional \$1.25 per hour for work in a condor, from the third (3rd) floor and up Additional \$1.25 per hour for work on the outside of the building from a swing stage or any suspended contrivance, from the ground up

PLAS0200-009 08/03/2022

| | Rates | Fringes |
|----------------|----------|---------|
| PLASTERER..... | \$ 47.37 | 19.64 |

PLAS0500-002 07/01/2020

| | Rates | Fringes |
|------------------------------------|----------|---------|
| CEMENT MASON/CONCRETE FINISHER.... | \$ 38.50 | 25.91 |

* PLUM0016-001 09/01/2023

| | Rates | Fringes |
|--|----------|---------|
| PLUMBER/PIPEFITTER | | |
| Work ONLY on new additions and remodeling of bars, restaurant, stores and commercial buildings not to exceed 5,000 sq. ft. of floor space..... | \$ 53.51 | 25.28 |
| Work ONLY on strip malls, light commercial, tenant improvement and remodel work..... | \$ 42.49 | 23.86 |
| All other work except work on new additions and remodeling of bars, restaurant, stores and commercial buildings not to exceed 5,000 sq. ft. of floor space and work on strip malls, light commercial, tenant improvement and remodel work..... | \$ 57.18 | 26.51 |

PLUM0345-001 09/01/2023

| | Rates | Fringes |
|----------------------------------|----------|---------|
| PLUMBER | | |
| Landscape/Irrigation Fitter..... | \$ 40.20 | 25.90 |
| Sewer & Storm Drain Work.... | \$ 44.29 | 23.28 |

ROOF0036-002 08/13/2023

| | Rates | Fringes |
|-------------|----------|---------|
| ROOFER..... | \$ 46.02 | 20.05 |

FOOTNOTE: Pitch premium: Work on which employees are exposed to pitch fumes or required to handle pitch, pitch base or pitch impregnated products, or any material containing coal tar pitch, the entire roofing crew shall receive \$1.75 per hour ""pitch premium"" pay.

SFCA0669-002 01/01/2024

| | Rates | Fringes |
|-----------------------|----------|---------|
| SPRINKLER FITTER..... | \$ 45.31 | 27.91 |

SHEE0105-003 01/01/2024

LOS ANGELES (South of a straight line drawn between Gorman and Big Pines)and Catalina Island, INYO, KERN (Northeast part, East of Hwy 395), MONO ORANGE, RIVERSIDE, AND SAN BERNARDINO COUNTIES

| | Rates | Fringes |
|---|----------|---------|
| SHEET METAL WORKER | | |
| (1) Commercial - New Construction and Remodel work..... | \$ 56.95 | 30.04 |
| (2) Industrial work including air pollution | | |

control systems, noise abatement, hand rails, guard rails, excluding aritechatural sheet metal work, excluding A-C, heating, ventilating systems for human comfort...\$ 56.95 30.04

TEAM0011-002 07/01/2023

| | Rates | Fringes |
|---------------|----------|---------|
| TRUCK DRIVER | | |
| GROUP 1..... | \$ 38.19 | 33.69 |
| GROUP 2..... | \$ 38.34 | 33.69 |
| GROUP 3..... | \$ 38.47 | 33.69 |
| GROUP 4..... | \$ 38.66 | 33.69 |
| GROUP 5..... | \$ 38.69 | 33.69 |
| GROUP 6..... | \$ 38.72 | 33.69 |
| GROUP 7..... | \$ 38.97 | 33.69 |
| GROUP 8..... | \$ 39.22 | 33.69 |
| GROUP 9..... | \$ 39.42 | 33.69 |
| GROUP 10..... | \$ 39.72 | 33.69 |
| GROUP 11..... | \$ 40.22 | 33.69 |
| GROUP 12..... | \$ 40.65 | 33.69 |

WORK ON ALL MILITARY BASES:

PREMIUM PAY: \$3.00 per hour additional.

[29 palms Marine Base, Camp Roberts, China Lake, Edwards AFB, El Centro Naval Facility, Fort Irwin, Marine Corps Logistics Base at Nebo & Yermo, Mountain Warfare Training Center, Bridgeport, Point Arguello, Point Conception, Vandenberg AFB]

TRUCK DRIVERS CLASSIFICATIONS

GROUP 1: Truck driver

GROUP 2: Driver of vehicle or combination of vehicles - 2 axles; Traffic control pilot car excluding moving heavy equipment permit load; Truck mounted broom

GROUP 3: Driver of vehicle or combination of vehicles - 3 axles; Boot person; Cement mason distribution truck; Fuel truck driver; Water truck - 2 axle; Dump truck, less than 16 yds. water level; Erosion control driver

GROUP 4: Driver of transit mix truck, under 3 yds.; Dumpcrete truck, less than 6-1/2 yds. water level

GROUP 5: Water truck, 3 or more axles; Truck greaser and tire person (\$0.50 additional for tire person); Pipeline and utility working truck driver, including winch truck and plastic fusion, limited to pipeline and utility work; Slurry truck driver

GROUP 6: Transit mix truck, 3 yds. or more; Dumpcrete truck, 6-1/2 yds. water level and over; Vehicle or combination of vehicles - 4 or more axles; Oil spreader truck; Dump truck, 16 yds. to 25 yds. water level

GROUP 7: A Frame, Swedish crane or similar; Forklift driver; Ross carrier driver

GROUP 8: Dump truck, 25 yds. to 49 yds. water level; Truck repair person; Water pull - single engine; Welder

GROUP 9: Truck repair person/welder; Low bed driver, 9 axles

or over

GROUP 10: Dump truck - 50 yds. or more water level; Water pull - single engine with attachment

GROUP 11: Water pull - twin engine; Water pull - twin engine with attachments; Winch truck driver - \$1.25 additional when operating winch or similar special attachments

GROUP 12: Boom Truck 17K and above

WELDERS - Receive rate prescribed for craft performing operation to which welding is incidental.

=====
Note: Executive Order (EO) 13706, Establishing Paid Sick Leave for Federal Contractors applies to all contracts subject to the Davis-Bacon Act for which the contract is awarded (and any solicitation was issued) on or after January 1, 2017. If this contract is covered by the EO, the contractor must provide employees with 1 hour of paid sick leave for every 30 hours they work, up to 56 hours of paid sick leave each year. Employees must be permitted to use paid sick leave for their own illness, injury or other health-related needs, including preventive care; to assist a family member (or person who is like family to the employee) who is ill, injured, or has other health-related needs, including preventive care; or for reasons resulting from, or to assist a family member (or person who is like family to the employee) who is a victim of, domestic violence, sexual assault, or stalking. Additional information on contractor requirements and worker protections under the EO is available at <https://www.dol.gov/agencies/whd/government-contracts>.

Unlisted classifications needed for work not included within the scope of the classifications listed may be added after award only as provided in the labor standards contract clauses (29CFR 5.5 (a) (1) (iii)).

The body of each wage determination lists the classification and wage rates that have been found to be prevailing for the cited type(s) of construction in the area covered by the wage determination. The classifications are listed in alphabetical order of ""identifiers"" that indicate whether the particular rate is a union rate (current union negotiated rate for local), a survey rate (weighted average rate) or a union average rate (weighted union average rate).

Union Rate Identifiers

A four letter classification abbreviation identifier enclosed in dotted lines beginning with characters other than ""SU"" or ""UAVG"" denotes that the union classification and rate were prevailing for that classification in the survey. Example: PLUM0198-005 07/01/2014. PLUM is an abbreviation identifier of the union which prevailed in the survey for this classification, which in this example would be Plumbers. 0198 indicates the local union number or district council number where applicable, i.e., Plumbers Local 0198. The next number, 005 in the example, is an internal number used in processing the wage determination. 07/01/2014 is the effective date of the most current negotiated rate, which in this example is July 1, 2014.

Union prevailing wage rates are updated to reflect all rate changes in the collective bargaining agreement (CBA) governing this classification and rate.

Survey Rate Identifiers

Classifications listed under the ""SU"" identifier indicate that no one rate prevailed for this classification in the survey and the published rate is derived by computing a weighted average rate based on all the rates reported in the survey for that classification. As this weighted average rate includes all rates reported in the survey, it may include both union and non-union rates. Example: SULA2012-007 5/13/2014. SU indicates the rates are survey rates based on a weighted average calculation of rates and are not majority rates. LA indicates the State of Louisiana. 2012 is the year of survey on which these classifications and rates are based. The next number, 007 in the example, is an internal number used in producing the wage determination. 5/13/2014 indicates the survey completion date for the classifications and rates under that identifier.

Survey wage rates are not updated and remain in effect until a new survey is conducted.

Union Average Rate Identifiers

Classification(s) listed under the UAVG identifier indicate that no single majority rate prevailed for those classifications; however, 100% of the data reported for the classifications was union data. EXAMPLE: UAVG-OH-0010 08/29/2014. UAVG indicates that the rate is a weighted union average rate. OH indicates the state. The next number, 0010 in the example, is an internal number used in producing the wage determination. 08/29/2014 indicates the survey completion date for the classifications and rates under that identifier.

A UAVG rate will be updated once a year, usually in January of each year, to reflect a weighted average of the current negotiated/CBA rate of the union locals from which the rate is based.

WAGE DETERMINATION APPEALS PROCESS

1.) Has there been an initial decision in the matter? This can be:

- * an existing published wage determination
- * a survey underlying a wage determination
- * a Wage and Hour Division letter setting forth a position on a wage determination matter
- * a conformance (additional classification and rate) ruling

On survey related matters, initial contact, including requests for summaries of surveys, should be with the Wage and Hour National Office because National Office has responsibility for the Davis-Bacon survey program. If the response from this initial contact is not satisfactory, then the process described in 2.) and 3.) should be followed.

With regard to any other matter not yet ripe for the formal process described here, initial contact should be with the Branch of Construction Wage Determinations. Write to:

Branch of Construction Wage Determinations
Wage and Hour Division

U.S. Department of Labor
200 Constitution Avenue, N.W.
Washington, DC 20210

2.) If the answer to the question in 1.) is yes, then an interested party (those affected by the action) can request review and reconsideration from the Wage and Hour Administrator (See 29 CFR Part 1.8 and 29 CFR Part 7). Write to:

Wage and Hour Administrator
U.S. Department of Labor
200 Constitution Avenue, N.W.
Washington, DC 20210

The request should be accompanied by a full statement of the interested party's position and by any information (wage payment data, project description, area practice material, etc.) that the requestor considers relevant to the issue.

3.) If the decision of the Administrator is not favorable, an interested party may appeal directly to the Administrative Review Board (formerly the Wage Appeals Board). Write to:

Administrative Review Board
U.S. Department of Labor
200 Constitution Avenue, N.W.
Washington, DC 20210

4.) All decisions by the Administrative Review Board are final.

=====

END OF GENERAL DECISION"

EXAMPLE

PROJECT SIGN

(For Community Development Block Grant Funded Projects)

Required for all Projects \$25,000 or over

(4' X 8')

[Contact HWS for City CDBG Funded Project]

**COUNTY OF RIVERSIDE
DEPARTMENT OF HOUSING & WORKFORCE SOLUTIONS**

SUPERVISOR CHUCK WASHINGTON

3rd DISTRICT



San Jacinto Street Pavement & Sidewalk Improvement Project

\$500,000.00

Figure 1 Change to your City's Logo

City of SAN JACINTO

Supervisor Chuck Washington



**(NAME)
CONTRACTOR**

**(NAME)
ENGINEER/ARCHITECT**

**FUNDED BY: U.S. DEPARTMENT OF HOUSING AND URBAN DEVELOPMENT
COMMUNITY DEVELOPMENT BLOCK GRANT PROGRAM
EQUAL OPPORTUNITY - AFFIRMATIVE ACTION EMPLOYER
EXECUTIVE ORDER 11246 AND SECTION 3 OF HOUSING AND URBAN
DEVELOPMENT ACT OF 1968, AS AMENDED**

Additional Federal Requirements

Whereas, the work under this Agreement is subject to applicable Federal, State, and local laws and regulations, including but not limited to the regulations pertaining to the Community Development Block Grant program (*24 CFR Part 570*) and the Uniform Administrative Requirement, Cost Principles, and Audit Requirements for Federal Awards (*2 CFR Part 200*). Contractor, sub-contractors, Consultants, and sub-consultants agree to comply with, and are subject to, all applicable requirements as follows:

1. ***Equal Employment Opportunity*** - Compliance with Executive Order 11246 of September 24, 1965, entitled "Equal Employment Opportunity", as amended by Executive Order 11375 of October 13, 1967, and as supplemented in Department of Labor regulations (41 CFR chapter 60). The Contractor/Consultant will not discriminate against any employee or applicant for employment because of race, color, religion, sex, or national origin. Contractor/Consultant will ensure that all qualified applicants will receive consideration for employment without regard to race, color, religion, sex or national origin. The Contractor/Consultant will take affirmative action to ensure that applicants are employed and the employees are treated during employment, without regard to their race color, religion, sex, or national origin. Such actions shall include, but are not limited to, the following: employment, up-grading, demotion, or transfer; recruitment or recruitment advertising; rates of pay or other forms of compensation; and selection for training, including apprenticeship. The Contractor/Consultant agrees to post in a conspicuous place, available to employees and applicants for employment, notices to be provided by the County setting forth the provisions of this non-discriminating clause.

2. ***Copeland "Anti-Kickback" Act*** (*18 U.S.C. 874 and 40 U.S.C. 276c*) All contracts and subgrants in excess of \$2,000 for construction or repair awarded by recipients and subrecipients shall include a provision for compliance with the Copeland "Anti-Kickback" Act (18 U.S.C. 874), as supplemented by Department of Labor regulations (29 CFR part 3, "Contractors and Subcontractors on Public Building or Public Work Financed in Whole or in Part by Loans or Grants from the United States"). The Act provides that each contractor or subrecipient shall be prohibited from inducing, by any means, any person employed in the construction, completion, or repair of public work, to give up any part of the compensation to which he is otherwise entitled. The recipient shall report all suspected or reported violations to HUD.

3. ***Davis-Bacon Act, as amended*** (*40 U.S.C. 276a to a-7*) When required by Federal program legislation, all construction contracts awarded by the recipients and subrecipients of more than \$2000 shall include a provision for compliance with the Davis-Bacon Act (40 U.S.C. 276a to a-7) and as supplemented by Department of Labor regulations (29 CFR part 5), "Labor Standards Provisions Applicable to Contracts Governing Federally Financed and Assisted Construction"). Under this Act, contractors shall be required to pay wages to laborers and mechanics at a rate not less than the minimum wages specified in a wage determination made by the Secretary of Labor. In addition, contractors shall be required to pay wages not less than once a week. The recipient shall place a copy of the current prevailing wage determination issued by the Department of Labor in each solicitation and the award of a contract shall be conditioned upon the acceptance of the wage determination. The recipient shall report all suspected or reported violations to HUD.

4. ***Contract Work Hours and Safety Standards Act (40 U.S.C. 327 through 333:*** Where applicable, all contracts awarded by recipients in excess of \$2000 for construction contracts and in excess of \$2500 for other contracts that involve the employment of mechanics or laborers shall include a provision for compliance with Sections 102 and 107 of the Contract Work Hours and Safety Standards Act (40 U.S.C. 327–333), as supplemented by Department of Labor regulations (29 CFR part 5). Under Section 102 of the Act, each contractor shall be required to compute the wages of every mechanic and laborer on the basis of a standard workweek of 40 hours. Work in excess of the standard workweek is permissible provided that the worker is compensated at a rate of not less than 1 1/2 times the basic rate of pay for all hours worked in excess of 40 hours in the workweek. Section 107 of the Act is applicable to construction work and provides that no laborer or mechanic shall be required to work in surroundings or under working conditions which are unsanitary, hazardous or dangerous. These requirements do not apply to the purchases of supplies or materials or articles ordinarily available on the open market, or contracts for transportation or transmission of intelligence.

5. ***Rights to Inventions Made Under a Contract or Agreement***— Contracts or agreements for the performance of experimental, developmental, or research work shall provide for the rights of the Federal Government and the recipient in any resulting invention in accordance with 37 CFR part 401, “Rights to Inventions Made by Nonprofit Organizations and Small Business Firms Under Government Grants, Contracts and Cooperative Agreements,” and any implementing regulations issued by HUD.

6. ***Rights to Data and Copyrights*** – Contractors and consultants agree to comply with all applicable provisions pertaining to the use of data and copyrights pursuant to 48 CFR Part 27.4, Federal Acquisition Regulations (FAR).

7. ***Clean Air Act (42 U.S.C. 7401 et seq.) and the Federal Water Pollution Control Act (33 U.S.C. 1251 et seq.)***, as amended—Contracts and subgrants of amounts in excess of \$200,000 shall contain a provision that requires the recipient to agree to comply with all applicable standards, orders or regulations issued pursuant to the Clean Air Act (42 U.S.C. 7401 et seq.) and the Federal Water Pollution Control Act as amended (33 U.S.C. 1251 et seq.). Violations shall be reported to HUD and the Regional Office of the Environmental Protection Agency (EPA).

8. ***Byrd Anti-Lobbying Amendment (31 U.S.C. 1352)***— Contractors who apply or bid for an award of \$200,000 or more shall file the required certification. Each tier certifies to the tier above that it will not and has not used Federal appropriated funds to pay any person or organization for influencing or attempting to influence an officer or employee of any agency, a member of Congress, officer or employee of Congress, or an employee of a member of Congress in connection with obtaining any Federal contract, grant or any other award covered by 31 U.S.C. 1352. Each tier shall also disclose any lobbying with non-Federal funds that takes place in connection with obtaining any Federal award. Such disclosures are forwarded from tier-to-tier up to the recipient.

9. ***Debarment and Suspension (E.O.s 12549 and 12689)***—No contract shall be made to parties listed on the General Services Administration's List of Parties Excluded from Federal Procurement or Nonprocurement Programs in accordance with E.O.s 12549 and 12689, “Debarment and Suspension,” as set forth at 24 CFR part 24. This list contains the names of

parties debarred, suspended, or otherwise excluded by agencies, and contractors declared ineligible under statutory or regulatory authority other than E.O. 12549. Contractors with awards that exceed the small purchase threshold shall provide the required certification regarding its exclusion status and that of its principal employees.

10. ***Drug-Free Workplace Requirements***—The Drug-Free Workplace Act of 1988 (42 U.S.C. 701) requires grantees (including individuals) of federal agencies, as a prior condition of being awarded a grant, to certify that they will provide drug-free workplaces. Each potential recipient must certify that it will comply with drug-free workplace requirements in accordance with the Act and with HUD's rules at 24 CFR part 24, subpart F.

11. ***Access to Records and Records Retention***: The Consultant or Contractor, and any sub-consultants or sub-contractors, shall allow all duly authorized Federal, State, and/or County officials or authorized representatives access to the work area, as well as all books, documents, materials, papers, and records of the Consultant or Contractor, and any sub-consultants or sub-contractors, that are directly pertinent to a specific program for the purpose of making audits, examinations, excerpts, and transcriptions. The Consultant or Contractor, and any sub-consultants or sub-contractors, further agree to maintain and keep such books, documents, materials, papers, and records, on a current basis, recording all transactions pertaining to this agreement in a form in accordance with generally acceptable accounting principles. All such books and records shall be retained for such periods of time as required by law, provided, however, notwithstanding any shorter periods of retention, all books, records, and supporting detail shall be retained for a period of at least four (4) years after the expiration of the term of this Agreement.

12. ***Federal Employee Benefit Clause***: No member of or delegate to the congress of the United States, and no Resident Commissioner shall be admitted to any share or part of this agreement or to any benefit to arise from the same.

13. ***Energy Efficiency***: Mandatory standards and policies relating to energy efficiency which are contained in the state energy conservation plan issued in compliance with the Energy Policy and Conservation Act (Pub. L. 94A 163, 89 Stat. 871).

14. ***Procurement of Recovered Materials (2 CFR 200.322.)*** A non-Federal entity that is a state agency or agency of a political subdivision of a state and its contractors must comply with section 6002 of the Solid Waste Disposal Act, as amended by the Resource Conservation and Recovery Act. The requirements of Section 6002 include procuring only items designated in guidelines of the Environmental Protection Agency (EPA) at 40 CFR part 247 that contain the highest percentage of recovered materials practicable, consistent with maintaining a satisfactory level of competition, where the purchase price of the item exceeds \$10,000 or the value of the quantity acquired by the preceding fiscal year exceeded \$10,000; procuring solid waste management services in a manner that maximizes energy and resource recovery; and establishing an affirmative procurement program for procurement of recovered materials identified in the EPA guidelines.

**CERTIFICATION OF BIDDER
REGARDING NONSEGREGATED FACILITIES**

Project Name: _____

Name of Bidder: _____

The above named Bidder hereby certifies that:

I do not maintain or provide for my employees any segregated facilities at any of my establishments, and that I do not permit my employees to perform their services at any location, under my control, where segregated facilities are maintained. As used in this certification, the term “segregated facilities” means any waiting rooms, work areas, rest rooms, wash rooms, restaurants and other eating areas, time clocks, locker rooms or other dressing areas, parking lots, drinking fountains, recreation or entertainment areas, transportation, and housing facilities provided for employees which are segregated by explicit directive or are in fact segregated on the basis of race, color, religion, national origin, or because of habits, local customs, or otherwise.

I further agree to obtain identical certifications from all proposed subcontractors prior to the award of subcontracts exceeding \$10,000.

Signature: _____

Name (Print): _____

Title: _____

Date: _____

**COUNTY OF RIVERSIDE
AFFIRMATIVE ACTION PROGRAM**

**ECONOMIC OPPORTUNITIES FOR SECTION 3 RESIDENTS
AND
SECTION 3 BUSINESS CONCERNS**

The work to be performed under this contract is subject to the requirements of section 3 of the Housing and Urban Development Act of 1968, as amended, 12 U.S.C. 1701u (section 3). The purpose of section 3 is to ensure that employment and other economic opportunities generated by HUD assistance or HUD-assisted projects covered by section 3, shall, to the greatest extent feasible, be directed to low- and very low-income persons, particularly persons who are recipients of HUD Assistance for housing.

AFFIRMATIVE ACTION POLICY STATEMENT

The County of Riverside, as the Community Development Block Grant Administrator, shall take Affirmative Action to ensure to the greatest extent feasible that:

1. Contracts for work (involving both construction and non-construction projects) funded from Community Development moneys be awarded to business located in and/or owned in substantial part by persons residing within the Section 3 covered project area.
2. Lower income residents of said project area are to be provided, to the greatest extent feasible, employment and training opportunities emanating from such contracts.

It will be established policy to:

1. Enlist the support of community agencies, schools and unions in the recruitment, hiring and training of low income persons residing within Section 3 project areas.
2. Ensure that project area businesses are afforded a maximum feasible opportunity to bid on contracts.
3. Ensure that contractors understand and comply with their obligations under the *Act (24 CFR Part 75)*.
4. Provide a system to periodically monitor and evaluate the effectiveness with which the plan is being carried out.

To ensure that we continue to meet our obligations and commitments we have developed a *Section 3 Affirmative Action Program*. All contractors and sub-contractors are expected to demonstrate a spirit of support and cooperation in the implementation of this program.

The Executive Director of the Community Development Agency will be responsible for the implementation, administration, and monitoring of our policy and program.

Date: February 8, 1988

Supervisor Walt P. Abraham Chairman, Board of Supervisors

II DEFINITION OF TERMS

1. Business concerns located within the Section 3 covered project area: Means those individuals or firms located within the relevant Section 3 covered project area as determined, pursuant to 24 CFR Part 75.
2. Business concerns owned in substantial part by persons residing in the Section 3 covered project area: Means those business concerns which are fifty-one (51) percent or more owned by persons residing within the relevant Section 3 covered project as determined pursuant to 24 CFR Part 75.
3. Contracting party: Means any entity which contracts with a contractor for the performance of work in connection with a Section 3 covered project.
4. Contractor: Means any entity which performs work in connection with a Section covered project.
5. Lower income resident of the area: A person residing in the Community Development Block Grant project area of the County of Riverside who's annual income does not exceed eighty (80) percent of the median income. (Calculations are to be based on the median income level as reported by HUD).
6. Project area: In most cases the project area will be bounded by the County limits (or participants' City limits as applicable). However, priority shall be given to persons living within the County's Impact Areas.

III SPECIFIC AFFIRMATIVE ACTION STEPS

In order to comply with Section 3 regulations affirmative action must be taken. This affirmative action will be at least as extensive and specific as the following:

- Each contractor and sub-contractor shall incorporate in all contracts for work in connection with a Section 3 covered project the following Section 3 Clause:
- Every applicant, recipient, contracting party, contractor, and sub-contractor shall incorporate, or cause to be incorporated, in all contracts for work in connection with Section 3 covered project, the following clause (referred to as a Section 3 Clause):

The work to be performed under this contract is on a project assisted under a program providing direct Federal financial assistance from the Department of Housing and Urban Development, and is subject to the requirements of Section 3 of the Housing and Urban Development act of 1968, as amended, *12 U.S.C. 1701u*. Section 3 requires that to the greatest extent feasible opportunities for training and employment be given to lower income residents of the project area and contracts for work in connection with the project be awarded to business concerns which are located in, or owned in substantial part by persons residing in the area of the project.

The parties to this contract will comply with the provisions of said Section 3 and the regulations issued pursuant thereto by the Secretary of Housing and Urban Development set forth in 24 CFR 570, and all applicable rules and orders of the Department issued hereunder prior to the execution of this contract. The parties to this contract certify and agree that they are under no contractual or other disability which would prevent them from complying with these requirements.

The contractor will send to each labor organization, or representative or workers, with which he has collective bargaining agreement or other contract, or understanding, if any, a notice advising the said labor organization or workers; representative of his commitments under this Section 3 Clause and shall post copies of the notice in a conspicuous place available to employees and applicants for employment or training.

The contractor will include this Section 3 Clause in every sub-tier contract for work in connection with the project and will, at the direction of the applicant for, or recipient of, the Federal financial assistance, take appropriate action pursuant to the sub-tier contract upon finding that the subcontractor is in violation of the regulations issued by the Secretary of Housing, and Urban Development, 24 CFR 570. The contractor will not enter into any sub-tier contract with any subcontractor where it has notice or knowledge that the latter has been found in violation of regulations under 24 CFR 570 and will not let any subcontract unless the subcontractor has first provided it with a preliminary statement of ability to comply with the requirements of these regulations.

Compliance with the provisions of Section 3, the regulations set forth in 24 CFR 570, and all applicable rules and orders of the Department issued thereunder prior to the execution of the contract, shall be a condition of the Federal financial assistance provided to the project binding upon the applicant or recipient for such assistance, its successors, and assigns. Failure to fulfill these requirements shall subject the applicant or recipient, its contractors and subcontractors, its successors, and assigns to those sanctions specified by the grant or loan agreement or contract through which Federal assistance is provided, and to such sanctions as are specified by 24 CFR Part 75.

All contractors and their subcontractors shall include as part of their bid proposal a copy of their Section 3 Affirmative Action Plan. The Plan should include the following:

1. A preliminary statement of workforce needs (skilled, semi-skilled, unskilled labor and trainees by category).
 2. Goals (in percentage) relative to utilization of lower income persons in project area.
 3. Goals relative to the project dollar amount of subcontractors to be awarded to project area business.
-

IV DISSEMINATION OF SECTION 3 PROGRAM POLICY

In order that all contractors of the County of Riverside have a full understanding of the County's position regarding this Section 3 Affirmative Action Plan the following procedures will be initiated:

1. All advertisements and invitations to bid will include the County's Section 3 Affirmative Action Plan requirements.
 2. All Community Development Block Grant contracts will include the County's Section 3 Affirmative Action Plan.
 3. The Section 3 Grievance Procedure and signs shall be placed at construction sites identifying the project as a Section 3 covered project.
-

V PROGRAM EVALUATION

Pursuant to Section 3 requirements (24 CFR Part 75,) the County of Riverside, as Block Grant Administrator, shall assist and actively cooperate with the Department of Housing and Urban Development in ensuring the compliance of our contractors and subcontractors.

All contractors shall:

1. Maintain a list of all lower income area residents who have applied whether on their own or on referral from any source.
2. Set forth evidence, acceptable to the Executive Director or the Community Development Agency that its actions were not an attempt to circumvent program requirements, if vacant apprentice or trainee positions in its organization are filled immediately prior to undertaking work pursuant to a Section 3 covered project.

VI COMPLAINT PROCEDURE

Who may file a complaint?

The following individuals and business concerns may, personally or through an authorized representative, file with the Assistant Secretary a complaint alleging noncompliance with section 3:

1. Any Section 3 resident on behalf of himself or herself, or as a representative of persons similarly situated, seeking employment, training or other economic opportunities generated from the expenditure of Section 3 covered assistance with a recipient or contractor, or by a representative who is not a section 3 resident but who represents one or more Section 3 residents;

2. Any Section 3 business concern on behalf of itself, or as a representative of other section 3 business concerns similarly situated, seeking contract opportunities generated from the expenditure of Section 3 covered assistance from a recipient or contractor, or by an individual representative of Section 3 business concerns.

Where to file a complaint?

A complaint must be filed with the:

Assistant Secretary for Fair Housing and Equal Opportunity
Department of Housing and Urban Development
Washington, DC, 20410.

Questions regarding Section 3 compliance, procedures for filing a complaint, or the County of Riverside's Affirmative Action Program, should be addressed to:

Department of Housing & Workforce Solutions
CDBG Program Administrator - Section 3 Program
3403 10th Street, Suite 300
Riverside, CA 92501

(951) 955-5933

BIDDER CERTIFICATION FOR SECTION 3 COMPLIANCE
(Housing and Community Development Act of 1968)

Project Title: _____ Amount of Bid: _____

The undersigned hereby certifies that he/she has read and understands Riverside County's Section 3 Affirmative Action Program as well as Section 3 of the *Housing and Community Development Act of 1968*, and further certifies adoption of, and adherence to, said program, and certifies understanding of the following for all construction contracts over \$200,000.

I. Employment Opportunities

I understand and agree that in the event that I am awarded this contract, and in the event that any new employment opportunities are created as a result of this CDBG-funded project, I will:

- a. Contact the U.S. Department of Housing and Urban Development (HUD) Section 3 website at www.hud.gov/section3 to review the list of certified Section 3 persons, within Riverside County, to be considered for available employment opportunities; and HUD Section 3 Opportunity Portal. at: <https://hudapps.hud.gov/OpportunityPortal/> _____ **Initial Here**
- b. Forward to the Department of Housing & Workforce Solutions all detailed job descriptions for new employment opportunities and Section 3 reports, in a form, at a place, and at a time as directed by the Department of Housing & Workforce Solutions. _____ **Initial Here**
- c. Present a list, of the number of total labor hours, Section 3 worker labor hours, and Targeted Section 3 worker labor hours expected to be generated from the initial contract and a list of projected number of available positions, to include job descriptions and wage rates. _____ **Initial Here**
- d. Notify Section 3 Coordinator of contractor interests regarding employment of Section 3 workers prior to hiring. _____ **Initial Here**
- e. Submit a list of core employees (including administrative, clerical, planning, and other positions pertinent to the construction trades) at the time of contact award. _____ **Initial Here**
- f. Post available positions and advertise job Section 3 workers openings at: www.rivcojobs.org _____ **Initial Here**
- g. Sign the Section 3 Plan. _____ **Initial Here**
- h. Complete your proposed workforce plan for this project below. _____ **Initial Here**

| JOB CATEGORY | CURRENT POSITIONS | NUMBER OF NEW HIRES IF AWARDED BID | NUMBER OF NEW HIRES PROPOSED TO BE SECTION 3 RESIDENTS | % OF NEW HIRES TO BE SECTION 3 |
|------------------------------|--------------------------|---|---|---------------------------------------|
| PROFESSIONALS | | | | |
| TECHNICIANS | | | | |
| OFFICE/CLERICAL | | | | |
| CONSTRUCTION BY TRADE | | | | |
| TRADE | | | | |
| TRADE | | | | |
| TRADE | | | | |
| TRADE | | | | |
| TRADE | | | | |
| TRADE | | | | |
| APPRENTICE | | | | |
| TRAINING | | | | |
| OTHER | | | | |
| TOTAL | | | | |

BIDDER CERTIFICATION FOR SECTION 3 COMPLIANCE

II. Subcontracting Opportunities

- a. I understand and agree that for any and all subcontracting opportunities that may result from this CDBG-funded project, I will contact the U.S. Department of Housing and Urban Development (HUD) Section 3 website at www.hud.gov/section3 to review the list of certified Section 3 Businesses, within Riverside County, to be considered for available subcontracting opportunities prior to selecting any subcontractor for my bid submittal.

_____ **Initial Here**

- b. I understand and agree that any and all sub-contracts and sub-tier agreements resulting from this CDBG-funded project are also subject to Section 3 compliance, and therefore, as the General/Prime Contractor, I am responsible to ensure compliance from all subcontractors.

_____ **Initial Here**

- i. Contact the U.S. Department of Housing and Urban Development (HUD) Section 3 website at www.hud.gov/section3 to review the list of certified Section 3 persons, within Riverside County, to be considered for available employment opportunities; and HUD Section 3 Opportunity Portal at: <https://hudapps.hud.gov/OpportunityPortal/>

_____ **Initial Here**

- j. Forward to the Department of Housing & Workforce Solutions all detailed job descriptions for new employment opportunities and Section 3 reports, in a form, at a place, and at a time as directed by the Department of Housing & Workforce Solutions.

_____ **Initial Here**

- k. Present a list, of the number of total labor hours, Section 3 worker labor hours, and Targeted Section 3 worker labor hours expected to be generated from the initial contract and a list of projected number of available positions, to include job descriptions and wage rates.

_____ **Initial Here**

- l. Notify Section 3 Coordinator of contractor interests regarding employment of Section 3 workers prior to hiring.

_____ **Initial Here**

- m. Submit a list of core employees (including administrative, clerical, planning, and other positions pertinent to the construction trades) at the time of contact award.

_____ **Initial Here**

- n. Post available positions and advertise job Section 3 workers openings at: www.rivcojobs.org

_____ **Initial Here**

Complete your Subcontracting Plan for this project below:

| TRADE | AMOUNT OF SUBCONTRACT(\$) | IS THE SUBCONTRACTOR SECTION 3 ELIGIBLE? YES OR NO | IF SUBCONTRACTOR IS SECTION 3, INDICATE ELIGIBLE STATUS. | |
|-------|---------------------------|--|--|--|
| | | | 51% Owned & Controlled by low or very low-income persons | 75% of Labor Hours over prior 3 months were performed by Section 3 Workers |
| | | | | |
| | | | | |
| | | | | |
| | | | | |
| | | | | |
| | | | | |

* Add additional sheets if necessary

Bidder (Company) Name: _____

Authorized Representative (Type Name): _____

Signature: _____

Date: _____

SUBCONTRACTOR CERTIFICATION FOR SECTION 3 COMPLIANCE

MUST BE COMPLETED BY ALL SUBCONTRACTORS

(Housing and Community Development Act of 1968)

Project Title: _____

Subcontractor: _____

Contractor/Bidder: _____

The undersigned hereby certifies that he/she has read and understands Riverside County's Section 3 Affirmative Action Program as well as Section 3 of the *Housing and Community Development Act of 1968*, and further certifies adoption of, and adherence to, said program, and certifies understanding of the following for all prime construction contracts over \$200,000:

a. I understand and agree that in the event that I am awarded a subcontract, and in the event that any new employment opportunities are created as a result of this CDBG-funded project, I will contact the U.S. Department of Housing and Urban Development (HUD) Section 3 website at www.hud.gov/section3 to review the list of certified Section 3 persons, within Riverside County, to be considered for available employment opportunities;

_____ **Initial Here**

b. I will forward to the Department of Housing & Workforce Solutions all detailed job descriptions and Section 3 reports, in a form, at a place, and at a time as directed by the Department of Housing & Workforce Solutions.

_____ **Initial Here**

Complete your proposed workforce plan for this project below:

| JOB CATEGORY | CURRENT POSITIONS | NUMBER OF NEW HIRES IF AWARDED BID | NUMBER OF NEW HIRES PROPOSED TO BE SECTION 3 RESIDENTS | % OF NEW HIRES TO BE SECTION 3 |
|-----------------------|-------------------|------------------------------------|--|--------------------------------|
| PROFESSIONALS | | | | |
| TECHNICIANS | | | | |
| OFFICE/CLERICAL | | | | |
| CONSTRUCTION BY TRADE | | | | |
| TRADE | | | | |
| TRADE | | | | |
| TRADE | | | | |
| TRADE | | | | |
| TRADE | | | | |
| TRADE | | | | |
| TRADE | | | | |
| APPRENTICE | | | | |
| TRAINING | | | | |
| OTHER | | | | |
| TOTAL | | | | |

Subcontractor (Company) Name: _____

Authorized Representative (Type Name): _____

Signature: _____

Date: _____

COUNTY OF RIVERSIDE
CDBG PROGRAM

**BIDDER CERTIFICATION ON
FEDERAL CONTRACT REQUIREMENTS**

PROJECT NAME: _____

CERTIFICATION:

I hereby certify that I have reviewed and understand the diversified Federal construction contract related requirements imposed on the Contractor(s) of HUD-funded construction projects, including but not limited to the following:

1. The subject project is being financed with Community Development Block Grant funds (*24 CFR Part 570*);
2. This project and all related construction contracts are subject to the U.S. Department of Housing and Urban Development's Federal Labor Standards Provisions (HUD 4010 – revised 06/2022) and
3. This project is subject to all applicable laws and regulations as listed in the General Summary of these Special Federal Provisions; and
4. If my bid is \$200,000 or more, this project and all related contracts will subject to Section 3 requirements (12 U.S.C.1701u).

CONTRACTOR'S NAME: _____

CONTRACTOR'S LICENSE NO.: _____

ADDRESS: _____

AUTHORIZED REPRESENTATIVE: _____ (Type Name)

SIGNATURE: _____

DATE: _____

QUESTIONNAIRE REGARDING BIDDERS

Bidder has been engaged in the contracting business under the present name of _____
_____, since _____ (Date).

Present business address is: _____

Federal Tax ID: _____ **Amount of Bid \$** _____

California Contractor's License No.: _____ **Expiration Date:** _____

UEI Number: _____ **or CAGE Code:** _____

Because this project is Federally-funded, it is necessary to obtain information concerning minority and other group participation for statistical purposes. The U.S. Department of Housing and Urban Development (HUD) uses this information to determine the degree to which its programs are being utilized by minority business enterprises and targeted group contractors.

A minority enterprise is defined by the Federal Government as a business that is fifty-one percent (51%) or more "minority-owned". Please check applicable box concerning the ownership of your business:

- American Indian or Native Alaskan
- Asian or Pacific Islander/Native Hawaiian
- Black/African American
- Hispanic
- White
- Hasidic Jews
- Other _____

A woman-owned enterprise is defined by the Federal Government as a business that is fifty-one percent (51%) or more woman-owned. Please check applicable box concerning the ownership of your business:

- Woman/Female owned
- Male owned

A Section 3 Contractor or Subcontractor is a business concern that is more than fifty-one percent (51%) owned by a low or very low-income person, or over 75 percent of the labor hours performed for the business over the prior three-month period are performed by Section 3 workers. Please check applicable box concerning the ownership of your business:

- Section 3 Business concern
- Non-Section 3 Business concern

The United States Department of Housing and Urban Development (HUD) is authorized to solicit the information requested in this form by virtue of Title 12, United States Code, Section 1701 et seq., and other regulations. It will not be disclosed or released outside of HUD without your consent, except as required or permitted by law.

LIST OF SUBCONTRACTORS

| SUBCONTRACTOR | FED. I.D.# | AMOUNT | ADDRESS/PHONE NO. |
|---------------|------------|--------|-------------------|
| | | | |
| | | | |
| | | | |
| | | | |
| | | | |
| | | | |
| | | | |

SUPPLIERS

| NAME OF SUPPLIER | ADDRESS/PHONE NO. | CONTRACT AMOUNT |
|------------------|-------------------|-----------------|
| | | |
| | | |
| | | |
| | | |
| | | |

This form is to be completed and submitted with the bid package.

POST CONTRACT AWARD FORMS

Valley-Wide Recreation

Bond No. **PERFORMANCE BOND.**

KNOW ALL PERSONS BY THESE PRESENTS:

THAT WHEREAS, the Valley-Wide Recreation and Park District, (hereinafter referred to as "District") has awarded to _____, (hereinafter referred to as the "Contractor") an agreement for the **Valley-Wide Sports Center and Winchester Park Accessibility Project Phase II** (hereinafter referred to as the "Project").

WHEREAS, the work to be performed by the Contractor is more particularly set forth in the Contract Documents for the Project dated _____, (hereinafter referred to as "Contract Documents"), the terms and conditions of which are expressly incorporated herein by reference; and

WHEREAS, the Contractor is required by said Contract Documents to perform the terms thereof and to furnish a bond for the faithful performance of said Contract Documents.

NOW, THEREFORE, we, _____, the undersigned Contractor and _____ as Surety, a corporation organized and duly authorized to transact business under the laws of the State of California, are held and firmly bound unto the District in the sum of _____ DOLLARS, (\$_____), said sum being not less than one hundred percent (100%) of the total amount of the Contract, for which amount well and truly to be made, we bind ourselves, our heirs, executors and administrators, successors and assigns, jointly and severally, firmly by these presents.

THE CONDITION OF THIS OBLIGATION IS SUCH, that, if the Contractor, his or its heirs, executors, administrators, successors or assigns, shall in all things stand to and abide by, and well and truly keep and perform the covenants, conditions and agreements in the Contract Documents and any alteration thereof made as therein provided, on its part, to be kept and performed at the time and in the manner therein specified, and in all respects according to their intent and meaning; and shall faithfully fulfill all obligations including the one (1) year guarantee of all materials and workmanship; and shall indemnify and save harmless the District, its officials, officers, employees, and authorized volunteers, as stipulated in said Contract Documents, then this obligation shall become null and void; otherwise it shall be and remain in full force and effect.

As a part of the obligation secured hereby and in addition to the face amount specified therefore, there shall be included costs and reasonable expenses and fees including reasonable attorney's fees, incurred by District in enforcing such obligation.

As a condition precedent to the satisfactory completion of the Contract Documents, unless otherwise provided for in the Contract Documents, the above obligation shall hold good for a period of one (1) year after the acceptance of the work by District, during which time if Contractor shall fail to make full, complete, and satisfactory repair and replacements and totally protect the District from loss or damage resulting from or caused by defective materials or faulty workmanship. The obligations of Surety hereunder shall continue so long as any obligation of Contractor remains. Nothing herein shall limit the District's rights or the Contractor or Surety's obligations under the Contract, law or equity, including, but not limited to, California Code of Civil Procedure Section 337.15.

Performance Bond

Whenever Contractor shall be, and is declared by the District to be, in default under the Contract Documents, the Surety shall remedy the default pursuant to the Contract Documents, or shall promptly, at the District's option:

- i. Take over and complete the Project in accordance with all terms and conditions in the Contract Documents; or
- ii. Obtain a bid or bids for completing the Project in accordance with all terms and conditions in the Contract Documents and upon determination by Surety of the lowest responsive and responsible bidder, arrange for a Contract between such bidder, the Surety and the District, and make available as work progresses sufficient funds to pay the cost of completion of the Project, less the balance of the contract price, including other costs and damages for which Surety may be liable. The term "balance of the contract price" as used in this paragraph shall mean the total amount payable to Contractor by the District under the Contract and any modification thereto, less any amount previously paid by the District to the Contractor and any other set offs pursuant to the Contract Documents.
- iii. Permit the District to complete the Project in any manner consistent with California law and make available as work progresses sufficient funds to pay the cost of completion of the Project, less the balance of the contract price, including other costs and damages for which Surety may be liable. The term "balance of the contract price" as used in this paragraph shall mean the total amount payable to Contractor by the District under the Contract and any modification thereto, less any amount previously paid by the District to the Contractor and any other set offs pursuant to the Contract Documents.

Surety expressly agrees that the District may reject any contractor or subcontractor which may be proposed by Surety in fulfillment of its obligations in the event of default by the Contractor.

Surety shall not utilize Contractor in completing the Project nor shall Surety accept a bid from Contractor for completion of the Project if the District, when declaring the Contractor in default, notifies Surety of the District's objection to Contractor's further participation in the completion of the Project.

The Surety, for value received, hereby stipulates and agrees that no change, extension of time, alteration or addition to the terms of the Contract Documents or to the Project to be performed thereunder shall in any way affect its obligations on this bond, and it does hereby waive notice of any such change, extension of time, alteration or addition to the terms of the Contract Documents or to the Project.

IN WITNESS WHEREOF, we have hereunto set our hands and seals this _____ day of _____, 20____.

(Corporate Seal)

Contractor/ Principal

By _____

Title _____

(Corporate Seal)

Surety

By _____
Attorney-in-Fact

(Attach Attorney-in-Fact Certificate)

Title _____

The rate of premium on this bond is _____ per thousand. The total amount of premium charges is \$_____.
(The above must be filled in by corporate attorney.)

THIS IS A REQUIRED FORM

Any claims under this bond may be addressed to:

(Name and Address of Surety)

(Name and Address of Agent or Representative for service of process in California, if different from above)

(Telephone number of Surety and Agent or Representative for service of process in California)

Valley-Wide Recreation

Bond No.

PAYMENT BOND

KNOW ALL MEN BY THESE PRESENTS That

WHEREAS, the Valley-Wide Recreation and Park District (hereinafter designated as the "District"), by action taken or a resolution passed _____, 20____, has awarded to _____ hereinafter designated as the "Principal," a contract for the work described as follows:

WHEREAS, said Principal is required to furnish a bond in connection with said contract; providing that if said Principal or any of its Subcontractors shall fail to pay for any materials, provisions, provender, equipment, or other supplies used in, upon, for or about the performance of the work contracted to be done, or for any work or labor done thereon of any kind, or for amounts due under the Unemployment Insurance Code or for any amounts required to be deducted, withheld, and paid over to the Employment Development Department from the wages of employees of said Principal and its Subcontractors with respect to such work or labor the Surety on this bond will pay for the same to the extent hereinafter set forth.

NOW THEREFORE, we, the Principal and _____ as Surety, are held and firmly bound unto the District in the penal sum of _____ Dollars (\$_____) lawful money of the United States of America, for the payment of which sum well and truly to be made, we bind ourselves, our heirs, executors, administrators, successors and assigns, jointly and severally, firmly by these presents.

THE CONDITION OF THIS OBLIGATION IS SUCH that if said Principal, his or its subcontractors, heirs, executors, administrators, successors or assigns, shall fail to pay any of the persons named in Civil Code Section 9100, fail to pay for any materials, provisions or other supplies, used in, upon, for or about the performance of the work contracted to be done, or for any work or labor thereon of any kind, or amounts due under the Unemployment Insurance Code with respect to work or labor performed under the contract, or for any amounts required to be deducted, withheld, and paid over to the Employment Development Department or Franchise Tax Board from the wages of employees of the contractor and his subcontractors pursuant to Revenue and Taxation Code Section 18663, with respect to such work and labor the Surety or Sureties will pay for the same, in an amount not exceeding the sum herein above specified, and also, in case suit is brought upon this bond, all litigation expenses incurred by the District in such suit, including reasonable attorneys' fees, court costs, expert witness fees and investigation expenses.

This bond shall inure to the benefit of any of the persons named in Civil Code Section 9100 so as to give a right of action to such persons or their assigns in any suit brought upon this bond.

It is further stipulated and agreed that the Surety on this bond shall not be exonerated or released from the obligation of this bond by any change, extension of time for performance, addition, alteration or modification in, to, or of any contract, plans, specifications, or agreement pertaining or relating to any scheme or work of improvement herein above described, or pertaining or relating to the furnishing of labor, materials, or equipment therefore, nor by any change or modification of any terms of payment or extension of the time for any payment pertaining or relating to any scheme or work of improvement herein above described, nor by any rescission or attempted rescission or attempted rescission of the contract, agreement or bond, nor by any conditions precedent or subsequent in the bond attempting to limit the right of

Payment Bond

recovery of claimants otherwise entitled to recover under any such contract or agreement or under the bond, nor by any fraud practiced by any person other than the claimant seeking to recover on the bond and that this bond be construed most strongly against the Surety and in favor of all persons for whose benefit such bond is given, and under no circumstances shall Surety be released from liability to those for whose benefit such bond has been given, by reason of any breach of contract between the owner or District and original contractor or on the part of any obligee named in such bond, but the sole conditions of recovery shall be that claimant is a person described in Civil Code Section 9100, and has not been paid the full amount of his claim and that Surety does hereby waive notice of any such change, extension of time, addition, alteration or modification herein mentioned, including but not limited to the provisions of sections 2819 and 2845 of the California Civil Code.

IN WITNESS WHEREOF, we have hereunto set our hands and seals this _____ day of _____, 20__.

(Corporate Seal)

Contractor/ Principal

By _____

Title _____

(Corporate Seal)

Surety

By _____
Attorney-in-Fact

(Attach Attorney-in-Fact Certificate)

Title _____

SUBCONTRACTOR QUESTIONNAIRE

Subcontractor has been engaged in the contracting business under the present name of:

_____, since
_____ (Date).

Present business address is: _____

Federal Tax ID: _____ **Amount of Subcontract \$** _____

State of California Contractor's License No.: _____

Expiration Date: _____

Because this project is Federally-funded, it is necessary to obtain information concerning minority and other group participation for statistical purposes. The U.S. Department of Housing and Urban Development (HUD) uses this information to determine the degree to which its programs are being utilized by minority business enterprises and targeted group contractors.

A minority enterprise is defined by the Federal Government as a business that is fifty-one percent (51%) or more "minority-owned". Please check applicable box concerning the ownership of your business:

- American Indian or Native Alaskan
- Asian or Pacific Islander/Native Hawaiian
- Black/African American
- Hispanic
- White
- Hasidic Jews
- Other _____

A woman-owned enterprise is defined by the Federal Government as a business that is fifty-one percent (51%) or more woman-owned. Please check applicable box concerning the ownership of your business:

- Woman/Female owned Male owned

A Section 3 Contractor or Subcontractor is a business concern that is more than fifty-one percent (51%) owned by a low or very low-income person, or a business concern that over 75 percent of the labor hours performed for the business over the prior three-month period are performed by Section 3 workers. Please check applicable box concerning the ownership of your business:

- Section 3 Business concern Non-Section 3 Business concern

The United States Department of Housing and Urban Development (HUD) is authorized to solicit the information requested in this form by virtue of Title 12, United States Code, Section 1701 et seq., and other regulations. It will not be disclosed or released outside of HUD without your consent, except as required or permitted by law.

DEPARTMENT OF HOUSING & WORKFORCE SOLUTIONS

| |
|--|
| HWS Use Only Project Name: _____ File #: _____ |
|--|

**CDBG / ESG / HOME PROGRAMS
Contractor / Sub-Contractor Questionnaire**

Note: The information requested is used to compile data required by HUD for Federally funded projects. The information is used by HUD to monitor and evaluate Minority Business Enterprise activities against the total program activity and the designated minority business enterprise (MBE) goals.

Privacy Act Notice = The United States Department of Housing and Urban Development, Federal Housing Administration, is authorized to solicit the information requested in this form by virtue of Title 12, United States Code, Section 1701 et seq., and regulation. It will not be disclosed or released outside the United States Department of Housing and Urban Development without your consent, except as required or permitted by law.

Project Name: _____

| Amount of Contract or Subcontract | Contractor or Subcontractor Business Racial / Ethnic (see below) | Type of Business 1-9 | Woman Owned Business (Y or N) | Prime Contractor Identification (ID) Number | Subcontractor Identification (ID) Number | Sec. 3 (Y or N) | Contact Person | Contractor / Subcontractor Name and Address | | | | |
|-----------------------------------|--|----------------------|-------------------------------|---|--|-----------------|----------------|---|--------|------|--|--|
| | | | | | | | | Name State | Street | City | | |
| | | | | | | | | | | | | |
| | | | | | | | | | | | | |
| | | | | | | | | | | | | |
| | | | | | | | | | | | | |
| | | | | | | | | | | | | |
| | | | | | | | | | | | | |
| | | | | | | | | | | | | |
| | | | | | | | | | | | | |
| | | | | | | | | | | | | |

Racial / Ethnic Codes:

- 1 = White Americans
- 2 = Black Americans
- 3 = Native Americans
- 4 = Hispanic Americans
- 5 = Asian / Pacific Americans
- 6 = Hasidic Jews

Type of Business / Trade Codes

- 1 = New Construction
- 2 = Substantial Rehab
- 3 = Repair
- 4 = Repair
- 5 = Project Management
- 6 = Professional
- 7 = Tenant Services
- 8 = Education Training
- 9 = Arch / Eng Appraisal
- 0 = Other

Section 3: Yes / No

A Section 3 Contractor or subcontractor is a business concern that provides economic opportunities to low and very low-income residents of the metropolitan area (or non-metropolitan county), including a business concern that is 51 percent or more owned by low-income residents.

PRINT NAME: _____

SIGNATURE: _____

DATE: _____

**CERTIFICATION OF SUBCONTRACTOR
REGARDING NONSEGREGATED FACILITIES**

Project Name:

Name of Subcontractor:

Name of General Contractor:

The above named Subcontractor hereby certifies that:

I do not maintain or provide for my employees any segregated facilities at any of my establishments, and that I do not permit my employees to perform their services at any location, under my control, where segregated facilities are maintained. As used in this certification, the term “segregated facilities” means any waiting rooms, work areas, rest rooms, wash rooms, restaurants and other eating areas, time clocks, locker rooms or other dressing areas, parking lots, drinking fountains, recreation or entertainment areas, transportation, and housing facilities provided for employees which are segregated by explicit directive or are in fact segregated on the basis of race, color, religion, national origin, or because of habits, local customs, or otherwise.

Signature: _____

Name (Print): _____

Title: _____

Date: _____

SECTION 3 SUMMARY REPORT

EXHIBIT PA-5

ECONOMIC OPPORTUNITIES FOR LOW AND VERY LOW-INCOME PERSONS

PROJECT NAME: _____

DATE: _____

CONTRACTOR: _____

SUBCONTRACTOR: _____

| JOB CATEGORY | NUMBER OF NEW HIRES | NUMBER OF NEW HIRES THAT ARE SECTION 3 RESIDENTS | % OF AGGREGATE NUMBER OF STAFF HOURS OF NEW HIRES THAT ARE SECTION 3 | % OF TOTAL STAFF HOURS FOR SECTION 3 EMPLOYEES |
|------------------------------|---------------------|--|--|--|
| PROFESSIONALS | | | | |
| TECHNICIANS | | | | |
| OFFICE / CLERICAL | | | | |
| CONSTRUCTION BY TRADE | | | | |
| TRADE | | | | |
| TRADE | | | | |
| TRADE | | | | |
| TRADE | | | | |
| TRADE | | | | |
| OTHERS | | | | |
| TOTAL | | | | |

NAME OF PERSON COMPLETING FORM: _____

SIGNATURE: _____

Section 3 "New Hires" refers to a person who is not on the Contractor's payroll for employment at the time of Contract award.

Recipients and contractors subject to Section 3 requirements must maintain appropriate documentation to establish that HUD financial assistance for CDBG-funded projects was directed to low-income and very low-income persons. Low-income persons means individuals whose income does not exceed 80% of the area median income, as established by HUD. Very low-income persons means individuals whose income does not exceed 50% of the area median income, as established by HUD.

CDBG PROJECT LABOR CLASSIFICATION SURVEY

PROJECT NAME: _____ CONTRACTOR: _____

PROJECT NUMBER: _____ SUBCONTRACTOR: _____

CLASSIFICATIONS

BRICKLAYER _____ LABORERS: GROUP 1 _____

CARPENTERS _____ GROUP 2 _____

CEMENT MASONS _____ GROUP 3 _____

DRYWALL HANGERS _____ GROUP 4 _____

ELECTRICIANS _____ GROUP 5 _____

IRON WORKERS _____ POWER EQUIPMENT OPERATORS

PAINTERS _____ GROUPS 1 – 21 _____

PLUMBERS _____ _____

ROOFERS _____ _____

SHEET METAL WORKERS _____ TRUCK DRIVERS

SOFT FLOOR LAYERS _____ GROUPS 1-11 _____

TILE LAYERS _____ _____

LANDSCAPE / IRRIGATION
FITTERS _____

LABORERS – STRIPPING _____

PLASTERER _____

OTHERS _____

**ADDITIONAL CLASSIFICATIONS
(Must be approved by HUD and DOL)**

CLASSIFICATIONS

PA-6 (Continued)

| PROJECT NAME: | | | WAGE DECISION NUMBER/MODIFICATION NUMBER: | | | |
|---|--------------------------------|------------------------|--|---------------------------------------|------------|-----------------------------|
| PROJECT NUMBER: | | | PROJECT COUNTY: | | | |
| WORK CLASSIFICATION | BASIC HOURLY RATE (BHR) | FRINGE BENEFITS | TOTAL HOURLY WAGE RATE | LABORERS FRINGE BENEFITS: | | \$ TOTAL WAGE |
| | | | | GROUP # | BHR | |
| Bricklayers | | | \$ | | | |
| Carpenters | | | \$ | | | \$ |
| Cement Masons | | | \$ | | | \$ |
| Drywall Hangers | | | \$ | | | \$ |
| Electricians | | | \$ | | | \$ |
| Iron Workers | | | \$ | | | \$ |
| Painters | | | \$ | OPERATORS FRINGE BENEFITS: | | \$ |
| Plumbers | | | \$ | GROUP # | BHR | TOTAL WAGE |
| Roofers | | | \$ | | | \$ |
| Sheet Metal Workers | | | \$ | | | \$ |
| Soft Floor Layers | | | \$ | | | \$ |
| Tapers | | | \$ | | | \$ |
| Tile Setters | | | \$ | TRUCK DRIVERS FRINGE BENEFITS: | | \$ |
| OTHER CLASSIFICATIONS | | | | GROUP # | BHR | TOTAL WAGE |
| | | | \$ | | | \$ |
| | | | \$ | | | \$ |
| | | | \$ | | | \$ |
| ADDITIONAL CLASSIFICATIONS (HUD Form 4230-A) | | | | | | |
| WORK CLASSIFICATION | BASIC HOURLY RATE | FRINGE BENEFITS | TOTAL HOURLY WAGE RATE | DATE OF HUD SUBMISSION TO DOL | | DATE OF DOL APPROVAL |
| | | | \$ | | | |
| | | | \$ | | | |
| | | | \$ | | | |
| | | | \$ | | | |

ACCESSIBILITY IMPROVEMENT FOR REGIONAL PARK

VALLEY RECREATION AND PARK DISTRICT

901 WEST ESPLANADE AVENUE SAN JACINTO, CA 92383

ACCESSIBILITY NOTES

- THE CLEAR WIDTH OF WALKING SURFACES SHALL BE 36" MIN. THE CLEAR WIDTH FOR WALKING SURFACES IN CORRIDORS SERVING AN OCCUPANT LOAD OF 10 OR MORE SHALL BE 44" MIN. THE CLEAR WIDTH FOR SIDEWALKS SHALL BE 48". 11B-403.5.1
- OPERABLE PARTS ON ACCESSIBLE ELEMENTS, ROUTES, ROOMS AND SPACES SHALL COMPLY WITH SECTION 11B-309. OPERABLE PARTS SHALL BE OPERABLE WITH ONE HAND AND SHALL NOT REQUIRE TIGHT GRASPING, PINCHING OR TWISTING OF THE WRIST. THE FORCE REQUIRED TO ACTIVATE OPERABLE PARTS SHALL BE 5 POUNDS MAX. OPERABLE PARTS THAT ARE INTENDED FOR USE ONLY BY SERVICE OR MAINTENANCE PERSONNEL SHALL NOT BE REQUIRED TO COMPLY.
- CLEAR FLOOR SPACE COMPLYING WITH SECTION 11B-305.7 THAT ALLOWS A FORWARD OR PARALLEL APPROACH BY A PERSON USING A WHEELCHAIR SHALL BE PROVIDED AT CONTROLS, DISPENSERS, RECEPTACLES, AND OTHER OPERABLE EQUIPMENT.
- THE HIGHEST AND LOWEST OPERABLE PART OF ALL CONTROLS, DISPENSERS, RECEPTACLES, AND OTHER OPERABLE EQUIPMENT SHALL BE PLACED WITHIN ONE OF THE REACH RANGES SPECIFIED IN SECTIONS 11B-308.
- ELECTRICAL AND COMMUNICATION SYSTEM RECEPTACLES ON BRANCH CIRCUITS OF 30 AMPERES OR LESS SHALL COMPLY WITH 11B-308 EXCEPT THE LOW REACH SHALL BE MEASURED TO THE BOTTOM OF THE OUTLET BOX AND THE HIGH REACH SHALL BE MEASURED TO THE TOP OF THE OUTLET BOX. FOR FORWARD (11B-308.2.1) AND SIDE (11B-308.3) REACH, THE LOW REACH IS 15" MIN. AND THE HIGH REACH IS 48" MAX. WHEN REACH IS OBSTRUCTED, E.G. @CABINETS THE HIGH REACH IS REDUCED TO 46" MAX. (11B-308.3.2)
- ACCESSIBLE LAVATORIES SHALL COMPLY WITH 11B-606. FAUCETS CONTROLS AND OPERATING MECHANISMS SHALL COMPLY WITH 11B-309. CONTROLS SHALL BE OPERABLE WITH ONE HAND AND SHALL NOT REQUIRE GRASPING, PINCHING, OR TWISTING OF THE WRIST. THE FORCE REQUIRED TO ACTIVATE FAUCET CONTROLS AND OPERATING MECHANISMS SHALL BE NO GREATER THAN 5 LBF. LEVER-OPERATED, PUSH-TYPE, AND ELECTRONICALLY CONTROLLED MECHANISMS ARE EXAMPLES OF ACCEPTABLE DESIGNS. SELF-CLOSING VALVES ARE ALLOWED IF THE FAUCET REMAINS OPEN FOR AT LEAST 10 SECONDS.
- EMPLOYEE WORKSTATIONS SHALL BE ON AN ACCESSIBLE ROUTE COMPLYING WITH DIVISION 4. SPACES AND ELEMENTS WITHIN EMPLOYEE WORKSTATIONS SHALL ONLY BE REQUIRED TO COMPLY WITH SECTIONS 11B-207.1, 11B-215.3, 11B-302 11B-303 AND 11B404.2.3. COMMON USE CIRCULATION PATHS WITHIN EMPLOYEE WORKSTATIONS SHALL COMPLY WITH SECTION 11B-206.2.8.
- IF SEATING SPACES FOR PERSONS IN WHEELCHAIRS IS PROVIDED AT FIXED TABLES OR COUNTERS, CLEAR FLOOR SPACE COMPLYING WITH SECTION 11B-305 SHALL BE PROVIDED. KNEE CLEARANCE SHALL EXTEND 25" MAX. UNDER AN ELEMENT AT 9" ABOVE THE FINISH FLOOR OR GROUND (11B-306.3). THE TOPS OF TABLES AND COUNTERS SHALL BE 34" MAX. FROM THE FLOOR OR GROUND. (11B-904)
- IF THE BUILDING INSPECTOR DETERMINES NONCOMPLIANCE WITH ANY CURRENT ACCESSIBILITY PROVISION OF THE LAW, HE/SHE SHALL REQUIRE SUBMITTAL OF COMPLETE AND DETAILED PLANS TO THE PLANNING AND BUILDING DEPARTMENT FOR FURTHER REVIEW. PLANS MUST CLEARLY SHOW ALL EXISTING NON-CONFORMING CONDITIONS AFFECTED BY THE REMODEL (INCLUDING SITE PLAN, FLOOR PLANS, DETAILS, ETC.) AND PROPOSED MODIFICATIONS OF THE DEFICIENCIES TO MEET CURRENT ACCESSIBILITY PROVISIONS.
- MAXIMUM EFFORT TO OPERATE EXTERIOR AND INTERIOR DOORS SHALL NOT EXCEED 5 POUNDS, WITH SUCH PULL OR PUSH EFFORT BEING APPLIED AT RIGHT ANGLES TO HINGED DOORS AND AT THE CENTER PLANE OF SLIDING OR FOLDING DOORS. COMPENSATING DEVICES OR AUTOMATIC DOOR OPERATORS MAY BE UTILIZED TO MEET THE ABOVE STANDARDS (11B-404.2.9). EXISTING EXTERIOR DOORS SHALL COMPLY WITH THE ABOVE REQUIREMENT. IF THE EXISTING EXTERIOR DOORS DO NOT COMPLY, THEY SHALL BE RETROFIT AS PART OF THIS PERMIT.

NOTE:

ALL NEW AND EXISTING FIXTURES AND ACCESSORIES TO COMPLY WITH 2022 CBC-11B MOUNTING HEIGHTS AND LOCATIONS. SEE DIMENSIONS ON FLOOR PLAN ON SHEET A-1.0 AND DETAILS ON SHEET A-1.1

FINISHES:

ALL FINISHES TO MATCH EXISTING, VERIFY WITH OWNER.

SCOPE OF WORK:

ALTERATIONS TO EXISTING RESTROOM FACILITY TO COMPLY WITH CA-11B ACCESSIBILITY CODE

SHEET INDEX

| NO. | SHEET | DESCRIPTION |
|-----|-------|----------------------------------|
| 1 - | T-1.0 | TITLE SHEET, SITE PLAN |
| 2 - | A-1.0 | EXISTING AND REMODEL FLOOR PLAN |
| 3 - | A-1.1 | RESTROOM & ACCESSIBILITY DETAILS |

CODE SUMMARY:

| | |
|------------|---------------------|
| BUILDING | 2022 CBC |
| MECHANICAL | 2022 CMC |
| PLUMBING | 2022 CPC |
| ELECTRICAL | 2022 CEC |
| ENERGY | CALIFORNIA TITLE 24 |
| CAL GREEN | 2022 |
| FIRE | 2022 CFC |
| ADA | 2010 |

2010 ADA STANDARDS FOR ACCESSIBLE DESIGN

WITH STATE AND LOCAL AMENDMENTS

THE ABOVE ARE THE CODES/STANDARDS THAT ARE APPLICABLE TO THIS PROJECT

PROJECT DIRECTORY

| | |
|--|---|
| OWNER: VALLEY WIDE RECREATION AND PARK DISTRICT 901 WEST ESPLANADE AVENUE SAN JACINTO, CA 92383 | ARCHITECT: HERRON + RUMANSOFF ARCHITECTS, INC. 530 ST. JOHN PLACE HEMET, CA 92543 CONTACT: RUSSELL RUMANSOFF (951) 652-4431 |
|--|---|

VICINITY MAP: N.T.S.

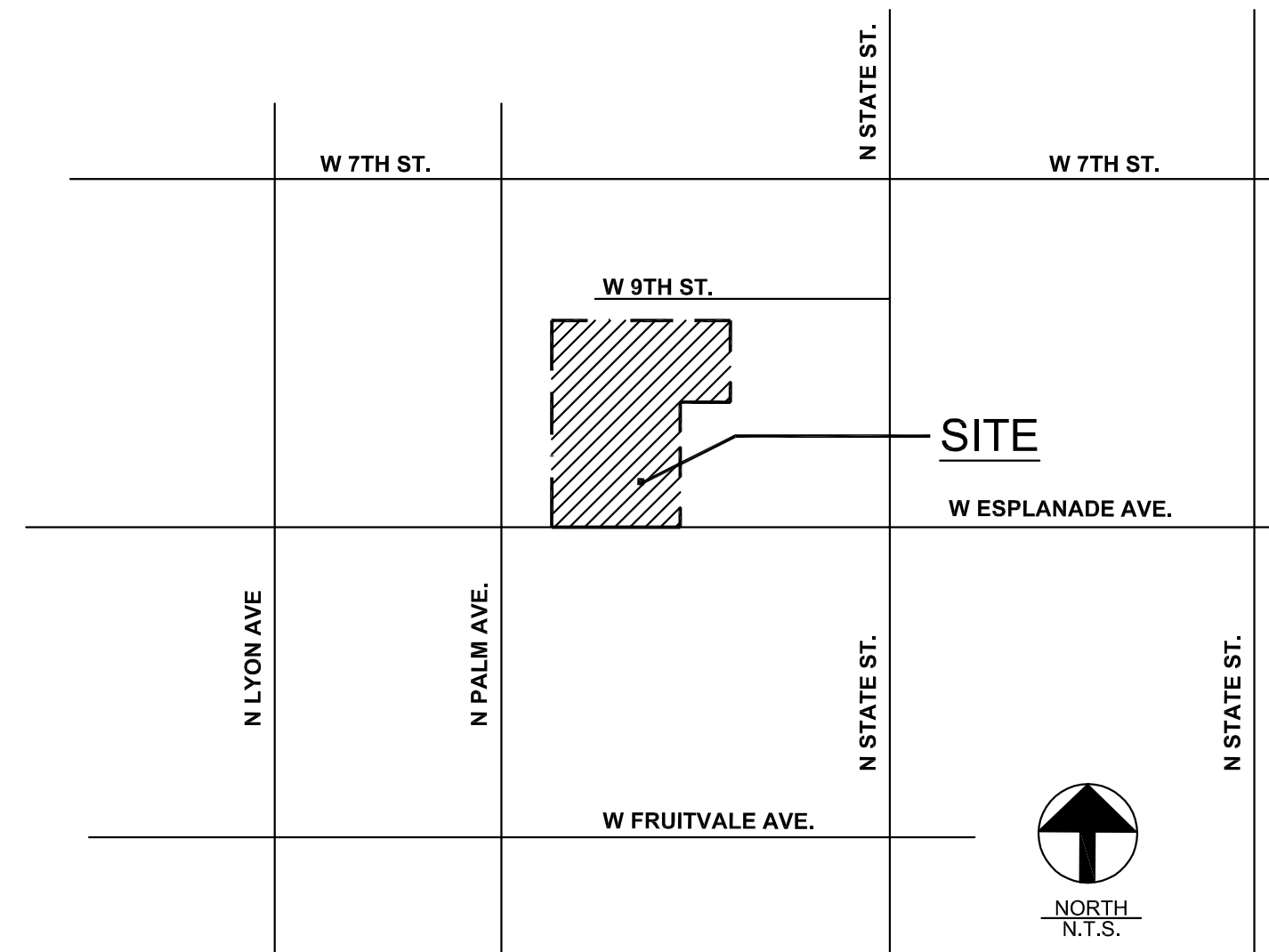

SITE / BUILDING DATA:

| | |
|--------------------|--|
| A.P.N.: | 435-190-180 |
| SITE ADDRESS: | 901 WEST ESPLANADE AVENUE SAN JACINTO, CALIFORNIA 92383 |
| LEGAL DESCRIPTION: | FARM LOTS 35 AND 38 OF THE ESTUDILLO LAND AND WATER COMPANY ADDITION, AS SHOWN BY MAP FILE IN BOO 9 PAGE 410 OF MAPS, RECORD OF SAN DIEGO COUNTY, CALIFORNIA |
| (E) LAND USE: | RECREATION BUILDING W/ GYMNASIUM |
| (E) ZONING: | A1-5 |
| LOT SIZE: | 35.29 ACRES |
| (E) BUILDING SIZE: | 20,638 S.F. |
| NUMBER OF STORIES: | 1 |
| CONSTRUCTION TYPE: | TYPE V-1 HOUR / SPRINKLERED |
| OCCUPANCY GROUP: | U |
| PROPERTY CLASS: | GYMNASIUM / RESTROOM FACILITY |
| OWNER: | VALLEY WIDE RECREATION AND PARK DISTRICT 901 WEST ESPLANADE AVENUE SAN JACINTO, CA 92383 |

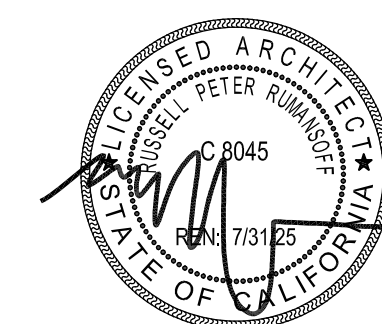

SCALE
1" = 20'-0"

A

All ideas, designs, and arrangements indicated or represented by these drawings are the property of Heron+Rumansoff Architects, Inc. and constitute the original and unpublished work of the architect and are intended to be used in connection with this specific project only. No copying, reproduction or reuse of these drawings is permissible without the written consent of Heron+Rumansoff Architects, Inc.

| | | | |
|---------------|---------------|---------------|---------------|
| 10-21-23 | 10-21-22 | 10-21-22 | 10-21-22 |
| 1ST SKETCH | 1ST SKETCH | 1ST SKETCH | 1ST SKETCH |
| CLIENT REVIEW | CLIENT REVIEW | CLIENT REVIEW | CLIENT REVIEW |
| 04-17-23 | 04-17-23 | 04-17-23 | 04-17-23 |
| P.C. #2 | P.C. #2 | P.C. #2 | P.C. #2 |
| 06-15-23 | 06-15-23 | 06-15-23 | 06-15-23 |
| P.C. #3 | P.C. #3 | P.C. #3 | P.C. #3 |
| 08-21-23 | 08-21-23 | 08-21-23 | 08-21-23 |

project
530 St. John Place Hemet, California 92543

consultant
951 652-4431

project
530 St. John Place Hemet, California 92543

ACCESSIBILITY IMPROVEMENT FOR
REGIONAL PARK
VALLEY RECREATION AND PARK DISTRICT
901 WEST ESPLANADE AVENUE
SAN JACINTO, CA 92383

architect's signature

sheet no. T-1.0

job no. 106-33-22

title sheet & site plan

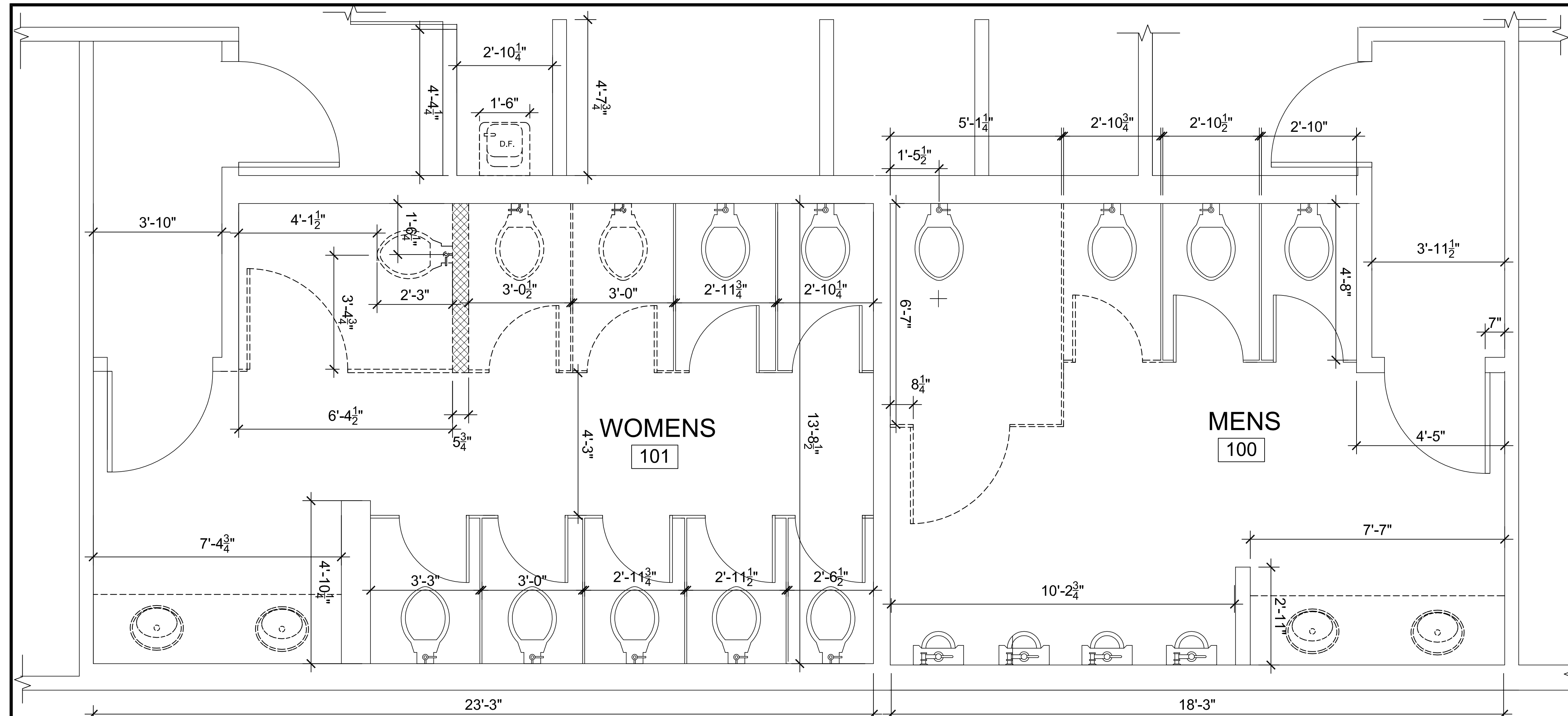

EXISTING WITH DEMO INDICATED RESTROOM FLOOR PLAN

GENERAL NOTES

1. INTERIOR DIMENSIONS ARE TO FACE OF FINISH MATERIAL UNLESS NOTED OTHERWISE
2. SEE MECHANICAL DRAWINGS FOR SPECIFIC HVAC REQUIREMENTS
3. SEE ELECTRICAL DRAWINGS FOR SPECIFIC REQUIREMENTS
4. SEE FINISH PLAN AND INTERIOR ELEVATIONS FOR DESCRIPTION ALL FINISHES
5. THE GENERAL CONTRACTOR SHALL COORDINATE THE VARIOUS TRADES WITH SPECIFIC VENDOR REQUIREMENTS
6. ALL GYPBOARD SHALL BE 5/8" TYPE "X", USE WRB GYPBOARD AT ALL TOILET ROOMS AND JANITOR CLOSETS
7. IN THE EVENT OF DISCREPANCY BETWEEN DRAWINGS AND ACTUAL CONDITIONS, THE GENERAL CONTRACTOR SHALL IMMEDIATELY NOTIFY THE ARCHITECT FOR RESOLUTION PRIOR TO PROCEEDING WITH WORK
8. THE CONTRACTOR SHALL PROVIDE CONTINUOUS 16 GA SHEET METAL BACKING AT ALL WALL MOUNTED EQUIPMENT, SINKS AND CABINETS
9. ANY ROOM THAT IS USED FOR AN ASSEMBLY PURPOSE SHALL HAVE THE OCCUPANT CAPACITY OF THE ROOM POSTED IN A CONSPICUOUS PLACE ON AN APPROVED SIGN NEAR THE MAIN EXIT OR EXIT DOORWAY (CBC 1094.3)
10. DELETED
11. ALL FIRE EXTINGUISHERS ARE RECESSED FIRE EXTINGUISHERS INSTALLED IN A 2X6 WALL

ACCESSIBILITY NOTES

1. FOR TACTILE ACCESSIBLE BUILDING ENTRANCE SIGNAGE COMPLY WITH CBC 11B-703
2. FOR ACCESSIBLE DOOR MANEUVERING CLEARANCES, SEE DETAIL 1A/A-1.1. COMPLY WITH CBC 11B-404
3. FOR TACTILE RESTROOM SIGNAGE, COMPLY WITH CBC 11B-703
4. PROVIDE ROOM IDENTIFICATION WITH RAISED CHARACTERS AND IN BRAILLE. COMPLY WITH CBC 11B-703.2022.
5. PROVIDE A LEVEL LANDING ON EACH SIDE OF A DOOR EXTENDING 60" ON DIRECTION OF DOOR SWING AND 48" IN OPPOSITE DIRECTION OF DOOR SWING, MEASURED WITH DOOR CLOSED. (CBC 11B-404.2.4.1 2022)
6. MANEUVERING CLEARANCE AT SWING DOORS AND GATES SHALL COMPLY WITH CBC 11B-404.2.4.1 (AND TABLE 11B-404.2.4.1 MANEUVERING CLEARANCE AT SLIDING DOORS, FOLDING DOORS AND DOORWAYS WITHOUT DOORS SHALL COMPLY WITH CBC 11B-404.2.4.2. RECESSED DOORS AND GATES SHALL COMPLY WITH CBC 11B-404.2.4.3.
7. PROVIDE SEATS/SPACES FOR PEOPLE USING WHEELCHAIRS IN ACCORDANCE WITH CBC TABLE 11B-221.2.1.1. SPECIALTY SEATING AREAS AND INTEGRATION SHALL COMPLY WITH CBC 11B-221.2.1.6 & 11B-221.2.2.
8. WHERE PROVIDED, AT LEAST ONE OF EACH TYPE OF SALES AND/OR SERVICE COUNTER SHALL COMPLY WITH CBC 11B-904.4 & 11B-227.3.

NOTE:
SEE DETAILA-1.1/2 FOR FIXTURES AND ACCESSORY MOUNTING HEIGHTS

NOTE:
ALL FINISHES TO MATCH EXISTING, VERIFY WITH OWNER.

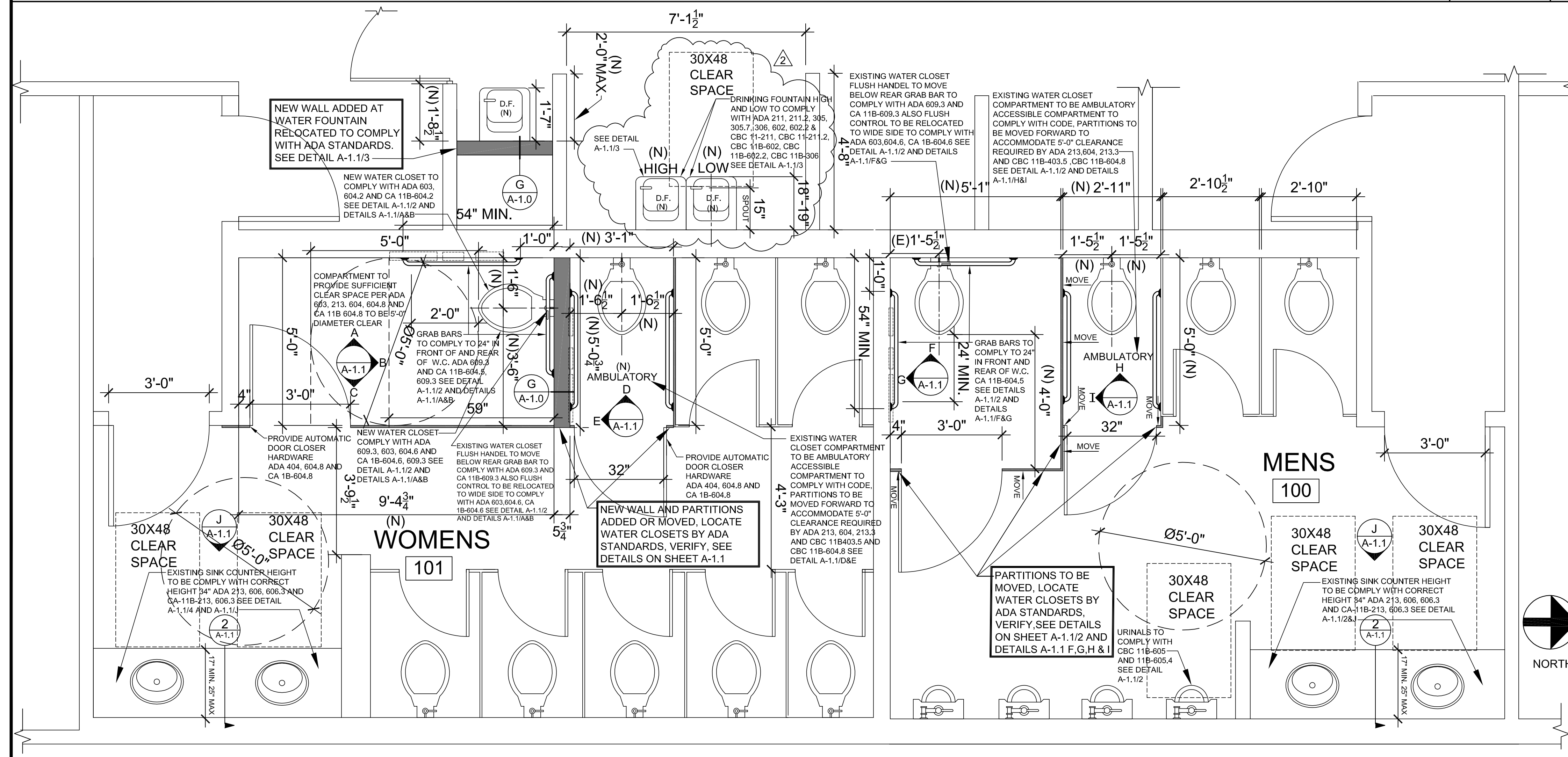

REVISED RESTROOM FLOOR PLAN TO COMPLY WITH CA 11B- CODES

WALL LEGEND

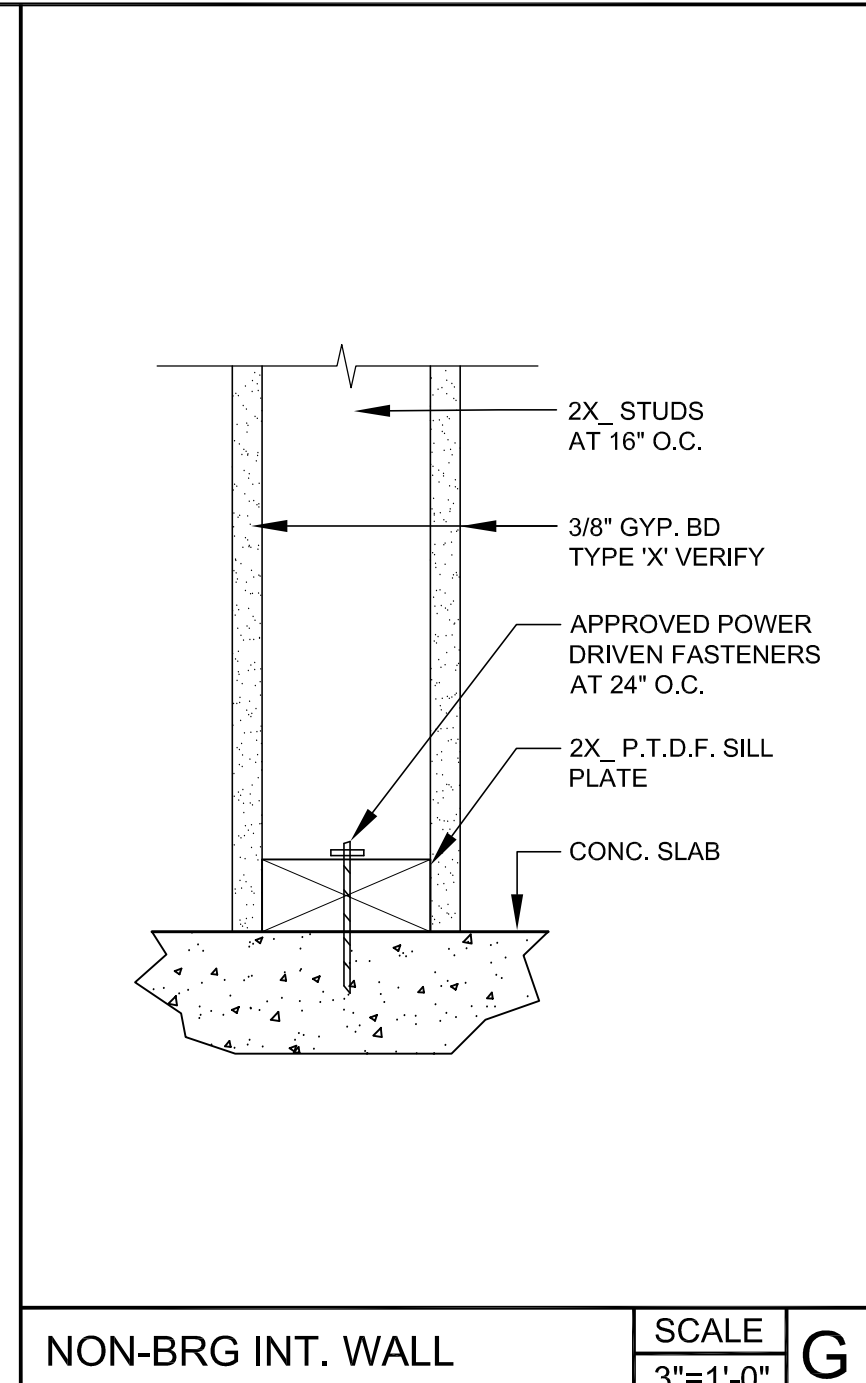
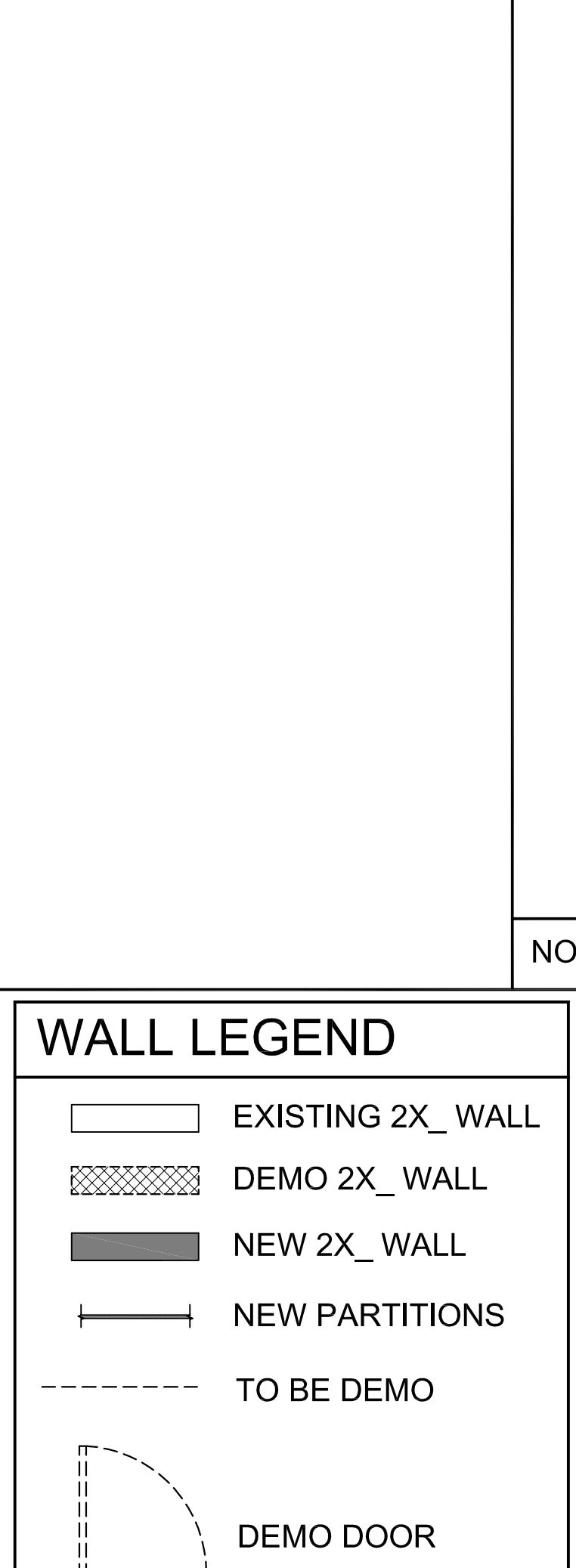

NON-BRG INT. WALL

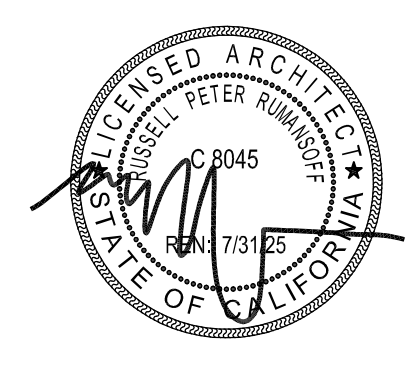

10-21-23
01-13-23
04-17-23
06-15-23
08-21-23

1ST SKETCH
CLIENT REVIEW
CLIENT REVIEW
P.C.#2
P.C.#3

10-21-22
10-21-22
10-21-22

1ST SKETCH
issue purpose
date

revisions

consultant

architect's signature

project

530 St. John Place Hemet, California 92343

ACCESSIBILITY IMPROVEMENT FOR
REGIONAL PARK
VALLEY RECREATION AND PARK DISTRICT
901 WEST ESPLANADE AVENUE
SAN JACINTO, CA 92393

architects, inc.

heron
rumanov

EXISTING AND REVISED FLOOR PLANS

106-33-22

job no. sht.description

A-1.0

sheet no.

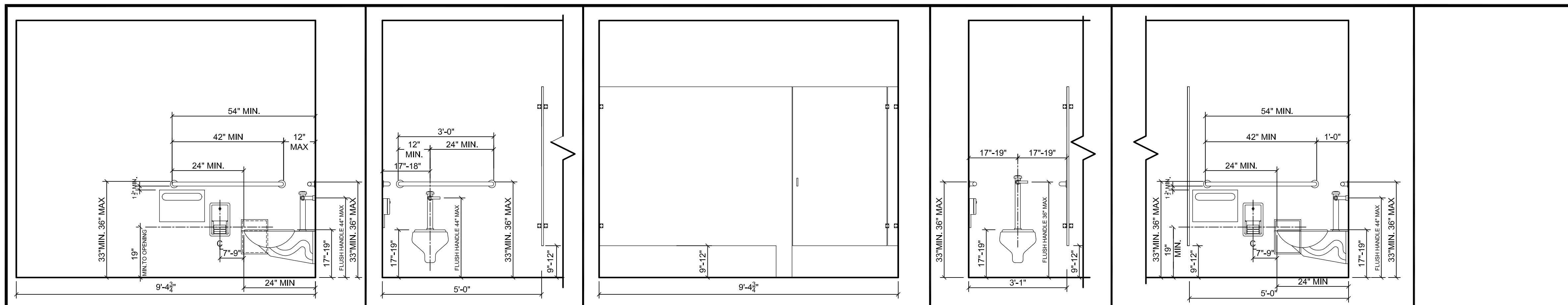

WOMENS RESTROOM SCALE 1/2" = 1'-0" A WOMENS RESTROOM SCALE 1/2" = 1'-0" B WOMENS RESTROOM SCALE 1/2" = 1'-0" C WOMENS AMULATORY SCALE 1/2" = 1'-0" D WOMENS AMULATORY SCALE 1/2" = 1'-0" E

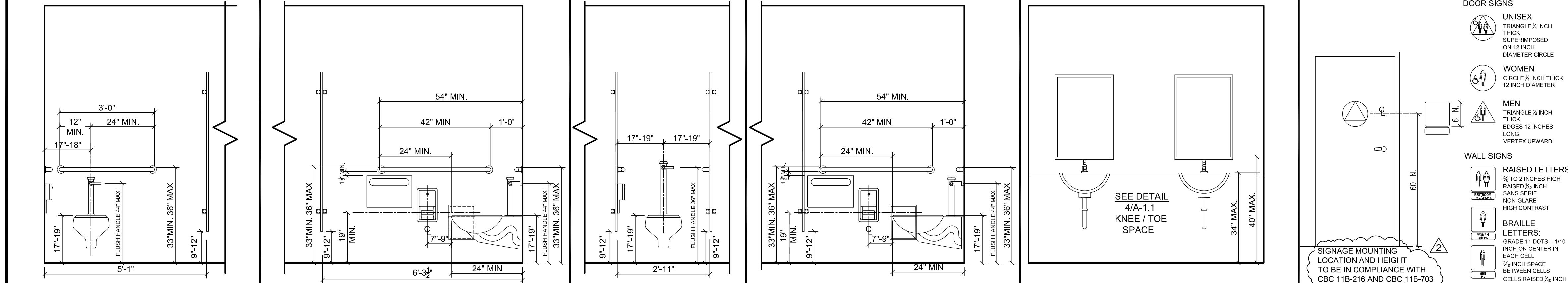

MENS RESTROOM SCALE 1/2" = 1'-0" F MENS RESTROOM SCALE 1/2" = 1'-0" G MENS AMBULATORY SCALE 1/2" = 1'-0" H MENS AMBULATORY SCALE 1/2" = 1'-0" I MENS & WOMENS RESTROOM SCALE 1/2" = 1'-0" J SIGNAGE SCALE NTS 1

FLOOR PLAN NOTES

- DELETED.
- IN OTHER THAN DWELLING UNITS, TOILET ROOM FLOORS, SHALL HAVE A SMOOTH, HARD, NON ABSORBENT SURFACE SUCH AS PORTLAND CEMENT, CONCRETE, CERAMIC TILE OR OTHER APPROVED MATERIAL WHICH EXTEND UPWARD ONTO THE WALLS AT LEAST 4 INCHES. WALLS WITHIN 24 INCHES OF THE SERVICE SINKS, WATER CLOSETS AND URINALS SHALL BE SIMILARLY FINISHED TO A HEIGHT OF 48 INCHES AND, EXCEPT FOR STRUCTURAL ELEMENTS, THE MATERIALS USED IN SUCH WALLS SHALL BE TYPE WHICH IS NOT ADVERSELY AFFECTED BY MOISTURE. CBC 1210.2.2
- PROVIDE ONE ACCESSIBLE LAVATORY IN COMPLIANCE WITH CBC 11B-606.
- THE CENTERLINE OF THE ACCESSIBLE WATER CLOSET SHALL BE 17 INCHES MINIMUM AND 18 INCHES MAX. FROM THE SIDE WALL OR PARTITION. (CBC 11B604.2)
- THE HEIGHT OF ACCESSIBLE WATER CLOSETS SHALL BE A MINIMUM OF 17 INCHES AND A MAXIMUM OF 19 INCHES TO THE TOP OF A MAXIMUM OF 2-INCH HIGH TOILET SEAT. (CBC 11B-604.4)
- GRAB BARS SHALL EXTEND 24" IN FRONT OF WATER CLOSET. (CBC FIG. 11B-604.5.1)
- WATER SUPPLY AND DRAIN PIPES UNDER LAVATORIES AND SINKS SHALL BE INSULATED OR OTHERWISE CONFIGURED TO PROTECT AGAINST CONTACT. THERE SHALL BE NO SHARP OR ABRASIVE SURFACES UNDER LAVATORIES AND SINKS CBC 11B-606.5
- CLEARANCE AROUND A WATER CLOSET SHALL BE 60 INCHES MINIMUM MEASURED PERPENDICULAR FROM THE SIDEWALL AND 56 INCHES MINIMUM MEASURED PERPENDICULAR FROM THE REAR WALL. A MINIMUM 60 INCHES WIDE AND 48 INCHES DEEP MANEUVERING SPACE SHALL BE PROVIDED IN FRONT OF THE WATER CLOSET. (CBC 11B-604.3.1)
- TOILET PAPER DISPENSERS AND SANITARY NAPKIN DISPOSAL UNITS SHALL COMPLY WITH SECTION 11B-604.7. COMBINATION ACCESSORY UNITS ARE NOT PERMITTED TO ENCRUSH INTO THE SPACE REQUIRED BY SECTION 11B-609.3 TOILET TISSUE DISPENSERS SHALL COMPLY WITH CBC 11B-309.4 AND SHALL BE 7 INCH MINIMUM AND 9 INCHES MAXIMUM IN FRONT OF THE WATER CLOSET MEASURED TO THE CENTERLINE OF THE DISPENSER. THE OUTLET OF THE DISPENSER SHALL BE BELOW THE GRAB BAR, 19 INCHES MINIMUM ABOVE THE FINISH FLOOR AND SHALL NOT BE LOCATED BEHIND GRAB BARS. DISPENSERS SHALL NOT BE OF A TYPE THAT CONTROLS DELIVERY OR THAT DOES NOT ALL CONTINUOUS PAPER FLOW. (CBC 11B604.7)
- ALL RECEPTACLE OUTLETS WITHIN 6 FEET OF ANY SINK NEED GFI PROTECTION CBC 210.8(B)(5)
- A PORTION OF THE COUNTER SURFACE THAT IS 36 INCHES LONG MINIMUM AND 34 INCHES HIGH MAXIMUM SHALL BE PROVIDED. KNEE AND TOE SPACE COMPLYING WITH SECTION 11B-306 SHALL BE PROVIDED UNDER THE COUNTER. A CLEAR FLOOR OR GROUND SPACE COMPLYING WITH SECTION 11B-305 SHALL BE POSITIONED FOR A FORWARD APPROACH TO THE COUNTER. (CBC 11B-904.2)
- DELETED
- SIGNAGE: AFFIX AN INTERNATIONAL ACCESSIBILITY SYMBOL ON ALL ACCESSIBLE ENTRANCES WHERE NOT ALL ENTRANCES COMPLY WITH CBC 11B-404, (CBC 11B-216.6)
- LANDING: PROVIDE A LEVEL LANDING ON EACH SIDE OF A DOOR EXTENDING 60" ON DIRECTION OF DOOR SWING AND 48" IN OPPOSITE DIRECTION OF DOOR SWING, MEASURED WITH DOOR CLOSED. [CBC 11B-404.2.4 & TABLE 404.2.4.1]

NOTE: SEE DETAIL 2 / A-1.1 FOR FIXTURE MOUNTING HEIGHTS

TABLE 11B-404.2.4.1
MANEUVERING CLEARANCES AT MANUAL SWINGING DOORS AND GATES

| TYPE OF USE | MINIMUM MANEUVERING CLEARANCE | |
|-----------------|--|--|
| | Door or gate side | Parallel to doorway (beyond latch side unless noted) |
| From front | Pull 60 inches (1524 mm) | 18 inches (457 mm) ¹ |
| From front | Push 48 inches (1219 mm) | 0 inches (0 mm) ² |
| From hinge side | Pull 60 inches (1524 mm) | 36 inches (914 mm) ² |
| From hinge side | Push 44 inches (1118 mm) ² | 22 inches (559 mm) ² |
| From latch side | Pull 60 inches (1524 mm) | 24 inches (610 mm) |
| From latch side | Push 44 inches (1118 mm) ² | 24 inches (610 mm) |

1. Add 12 inches (305 mm) if closer and latch are provided.
2. Add 4 inches (102 mm) if closer and latch are provided.
3. Beyond hinge side.
4. Add 4 inches (102 mm) if closer is provided.
5. Add 6 inches (152 mm) set exterior side of exterior doors.

ACCESSIBILITY CLEARANCES

- A CLEAR FLOOR SPACE COMPLYING WITH SECTION 11B-305 POSITIONED FOR A FORWARD APPROACH SHALL BE PROVIDED. KNEE AND TOE CLEARANCE COMPLYING WITH SECTION 11B-306 SHALL BE PROVIDED (CBC - 11B-902.2)
- THE TOPS OF DINING SURFACES AND WORK SURFACES SHALL BE 28 INCHES (711 MM) MINIMUM AND 34 INCHES (864 MM) MAXIMUM ABOVE THE FINISH FLOOR OR GROUND. (CBC - 11B-902.3)
- CLEAR FLOOR OR GROUND SPACE SHALL COMPLY WITH THE FOLLOWING:



MANEUVERING CLEARANCE IN AN ALCOVE, PARALLEL APPROACH SCALE NTS 1A CLEAR FLOOR OR GROUND SPACE UNOBSTRUCTED FORWARD REACH POSITION OF CLEAR FLOOR OR GROUND SPACE MANEUVERING CLEARANCE IN AN ALCOVE, FORWARD APPROACH OBSTRUCTED HIGH FORWARD REACH UNOBSTRUCTED SIDE REACH OBSTRUCTED HIGH SIDE REACH

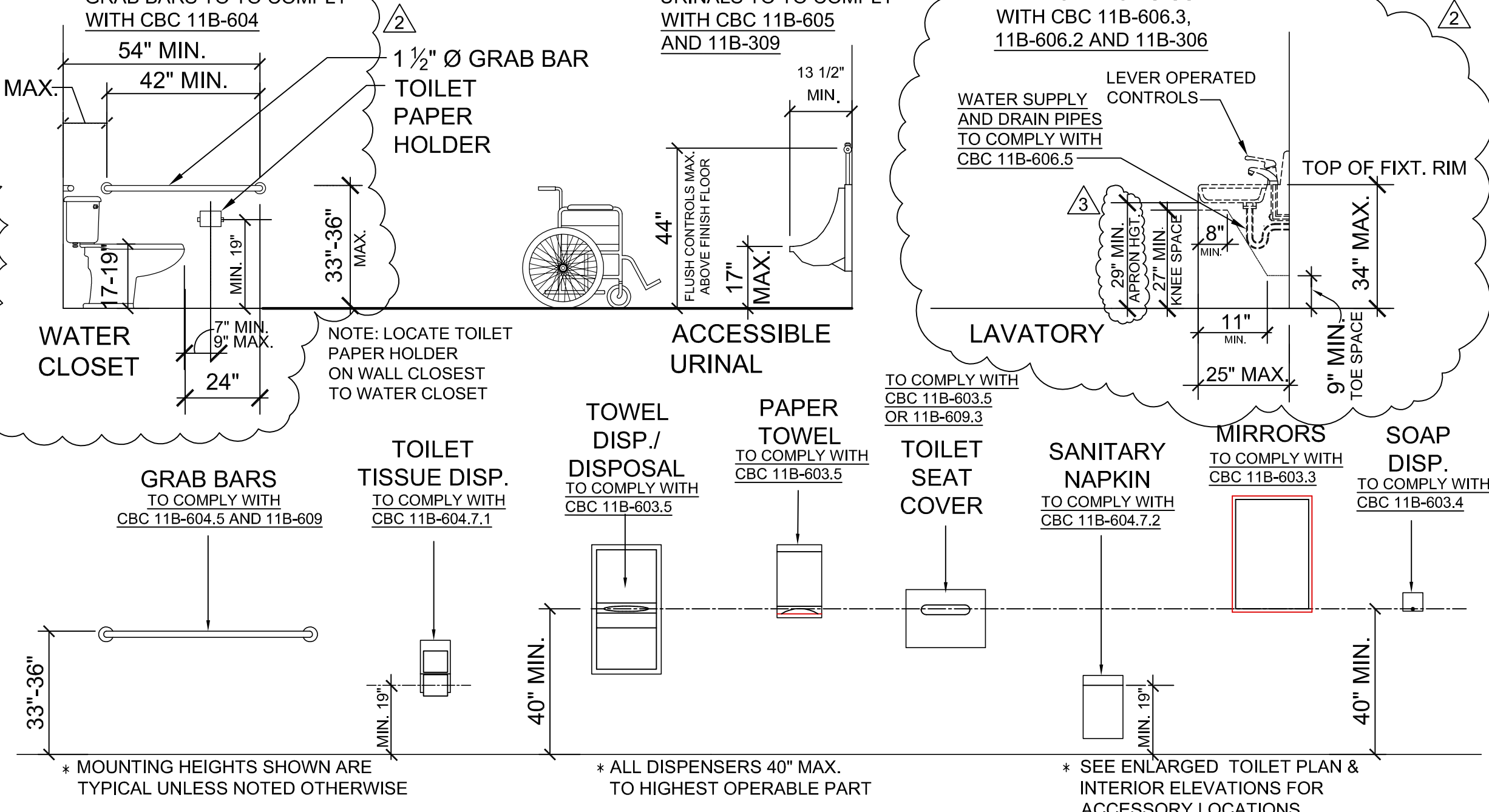

FIXTURE MOUNTING HEIGHTS SCALE NTS 2

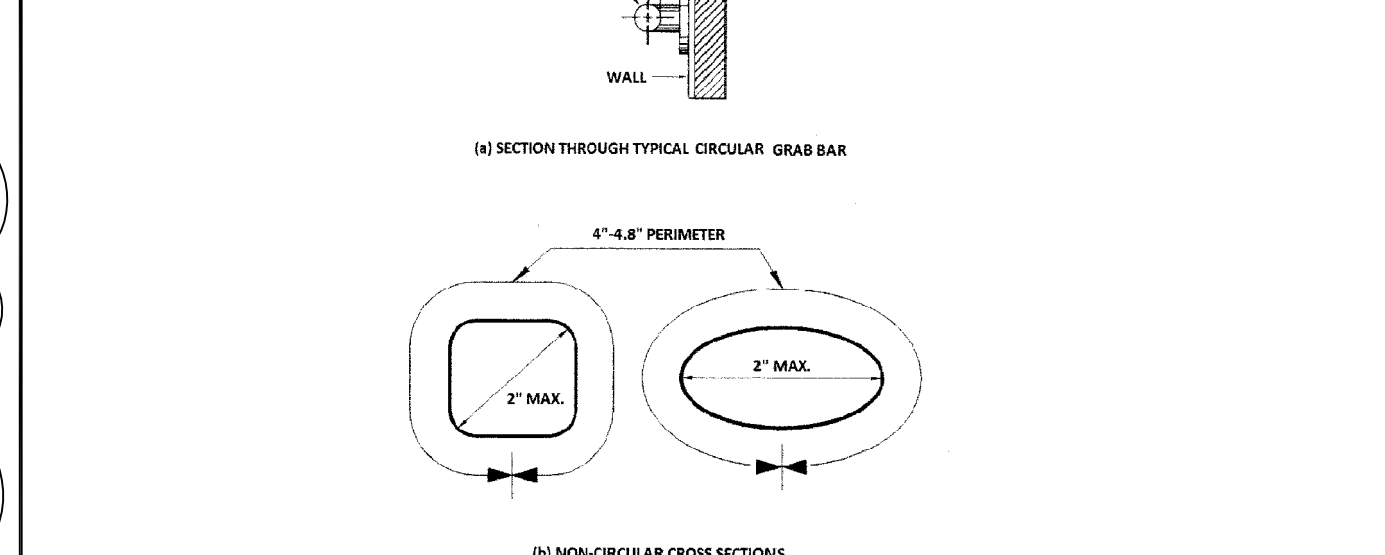

GRAB BARS SCALE NTS 5

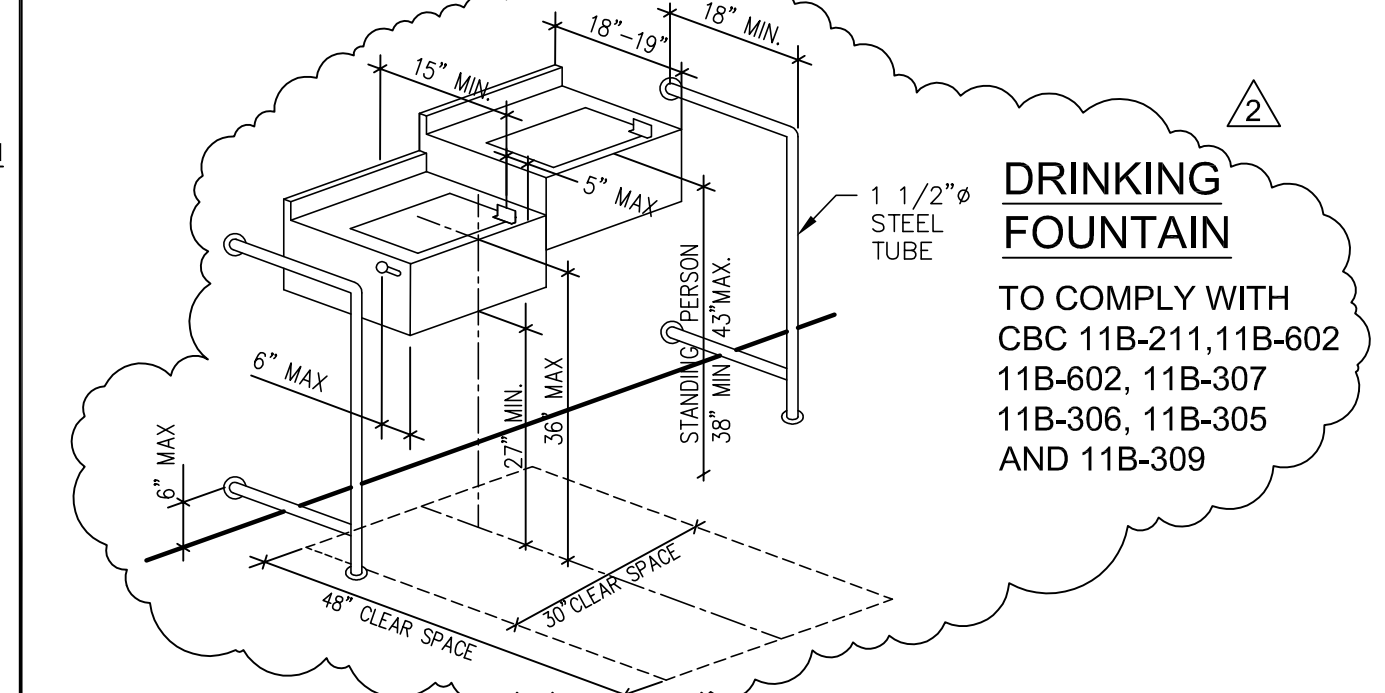

DRINKING FOUNTAINNS SCALE NTS 3

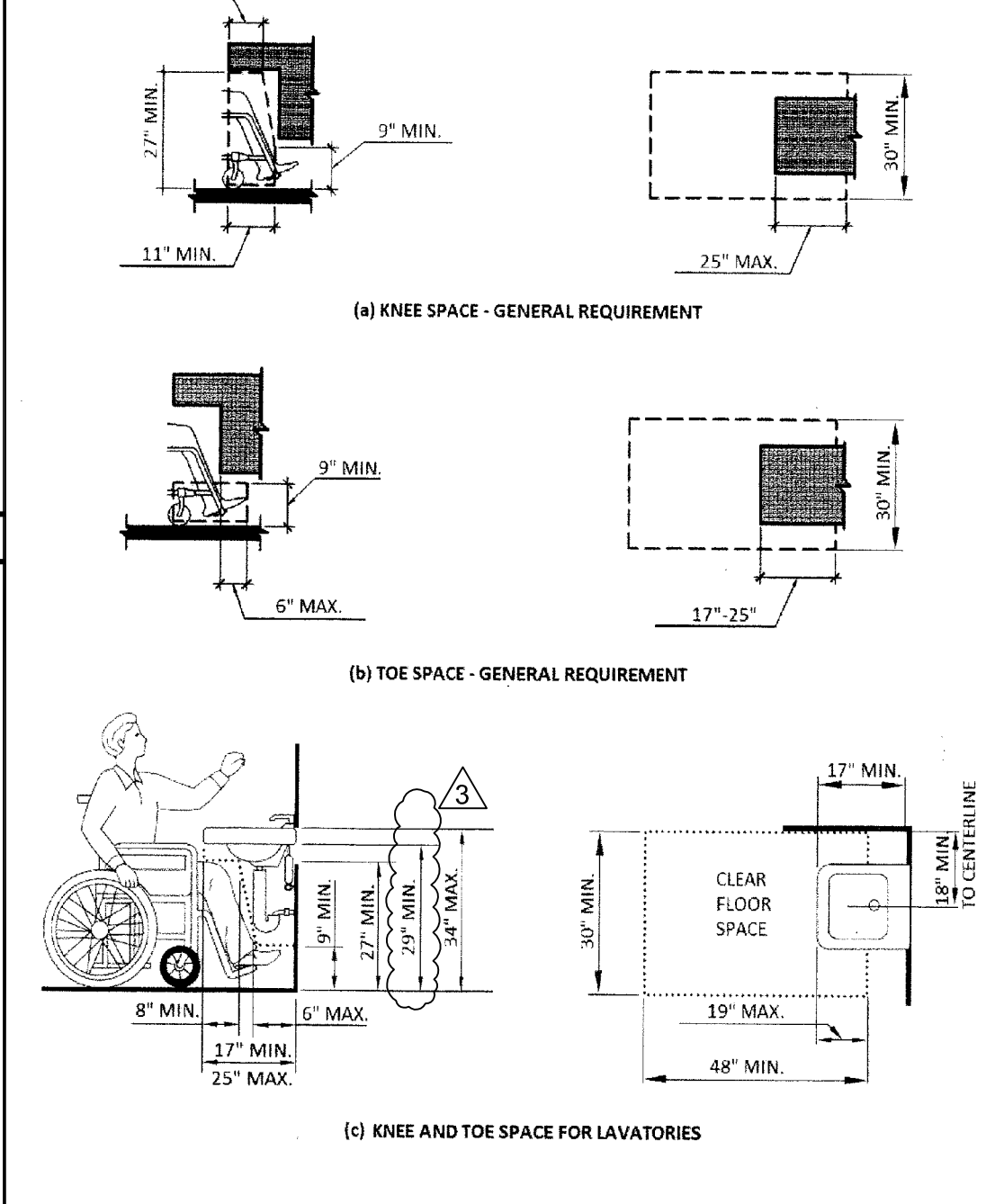

KNEE & TOE SPACE SCALE NTS 4

DOOR ACCESSIBILITY NOTES:

- MIN. DOOR STRIKE EDGE DISTANCE OF 24" @ EXTERIOR DOORS, 12" ON THE PUSH SIDE AND 18" ON THE PULL SIDE FOR ALL DOORS.
- MAX. HEIGHT OF THRESHOLD SHALL BE BEVELED WITH A SLOPE NOT STEEPER THAN 1:2. CBC 11B-404.2.5 AND 11B-303
- DOOR OPENING SHALL SWING TO THE FULLY OPEN POSITION WHEN THE OPENING FORCE APPLIED TO THE LATCH SIDE SHALL NOT EXCEED THE FOLLOWING PER 1010.1.3 CBC 2022
5 LBS FOR INTERIOR AND EXTERIOR DOORS
15 LBS FOR FIRE RATED DOORS
- ALL DOOR OPENINGS SHALL BE MINIMUM 32" CLEAR WITH DOOR OPEN @ 90°.
- DOOR OPERATING DEVICES SHALL NOT REQUIRE TIGHT GRASPING, PINCHING OR TWISTING OF THE WRIST TO OPERATE. PER CBC 11B-404.2.7 AND 11B-308.4 CBC 2022
- ALL HAND-ACTIVATED DOOR OPENING HARDWARE MEETS THE FOLLOWING REQUIREMENTS, PER SECTION 11B-404.2.7 AND 11B-308.4 CBC 2022
A. LATCHING, OR LOCKING, DOORS IN A PATH OF TRAVEL ARE OPERATED WITH A SINGLE EFFORT BY LEVER TYPE HARDWARE, BY PANIC BARS, PUSH-PULL ACTIVATING BARS, OR OTHER HARDWARE DESIGNED TO PROVIDE PASSAGE WITHOUT REQUIRING THE ABILITY TO GRASP THE OPENING HARDWARE.
B. OPERABLE PARTS SHALL BE 34" MINIMUM AND 44" MAXIMUM ABOVE THE FINISHED FLOOR OR GROUND
- DOORS SHALL BE PROVIDED WITH FLOOR OR LANDING ON EACH SIDE OF THE DOOR. FLOOR OR LANDING SHALL NOT BE MORE THAN 1/2" LOWER THAN THE THRESHOLD.
- MANEUVERING CLEARANCES COMPLY WITH 2022 CBC 11B-404.2.

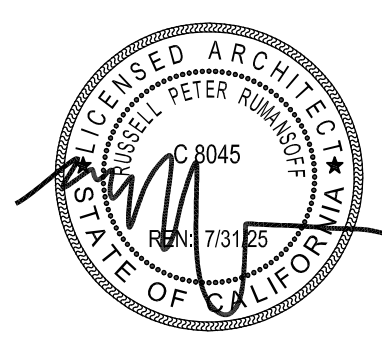

ACCESSIBILITY IMPROVEMENT FOR REGIONAL PARK VALLEY RECREATION AND PARK DISTRICT 901 WEST ESPLANADE AVENUE SAN JACINTO, CA 92583

10-21-22 10-21-22 10-21-22
1ST SKETCH 1ST SKETCH 1ST SKETCH
CLIENT REVIEW CLIENT REVIEW CLIENT REVIEW
P.C.#2 P.C.#2 P.C.#2
04-12-23 04-12-23 04-12-23
06-15-23 06-15-23 06-15-23
08-21-23 08-21-23 08-21-23

revisions
consultant
architect's signature
date
issue purpose

ACCESSIBILITY IMPROVEMENT FOR REGIONAL PARK VALLEY RECREATION AND PARK DISTRICT 901 WEST ESPLANADE AVENUE SAN JACINTO, CA 92583

project
950 St. John Place Hemet, California 92543

architects_inc

ACCESSIBILITY DETAILS AND NOTES
106-33-22
A-1.1
job no. shi.description
sheet no.

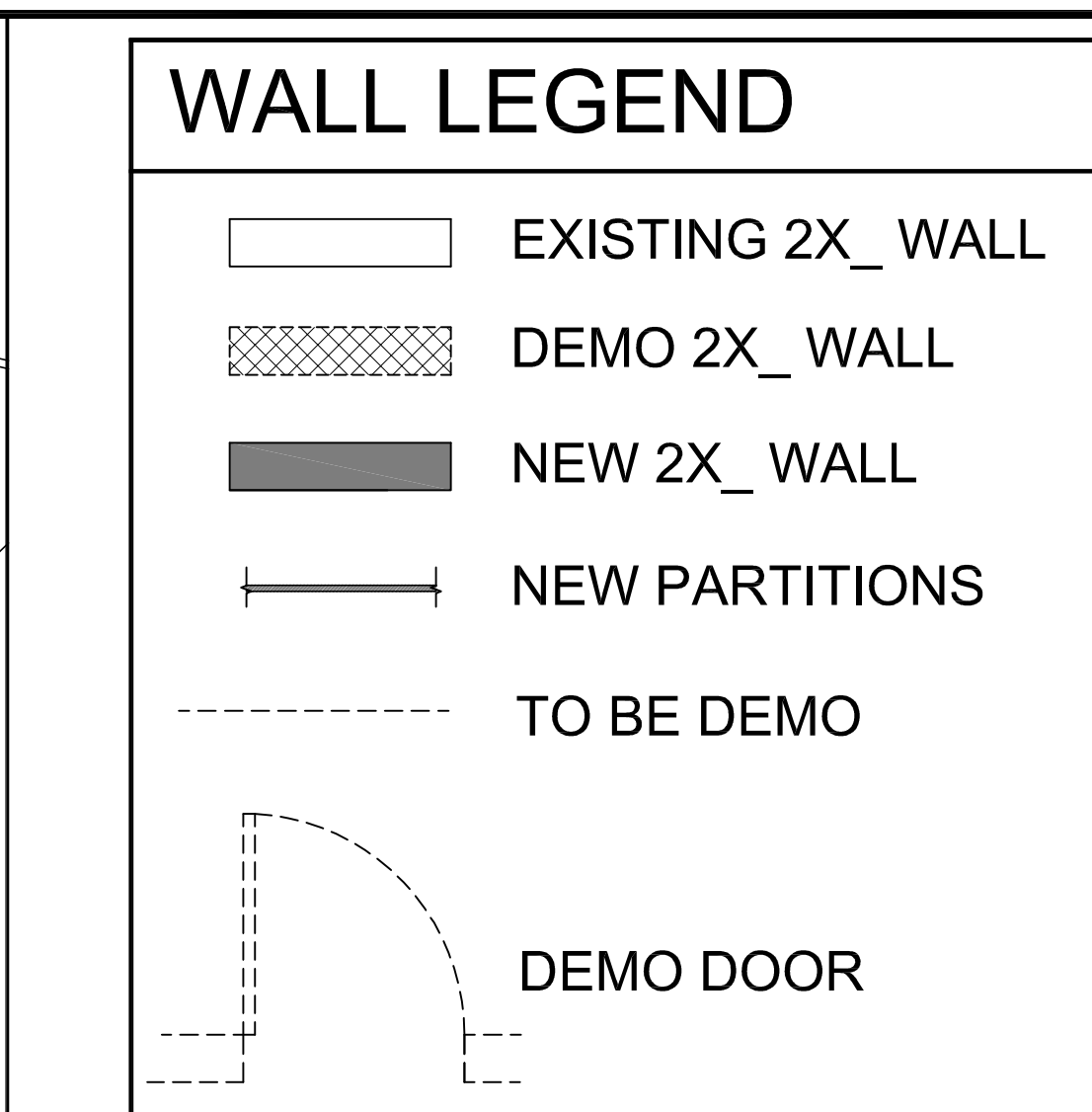
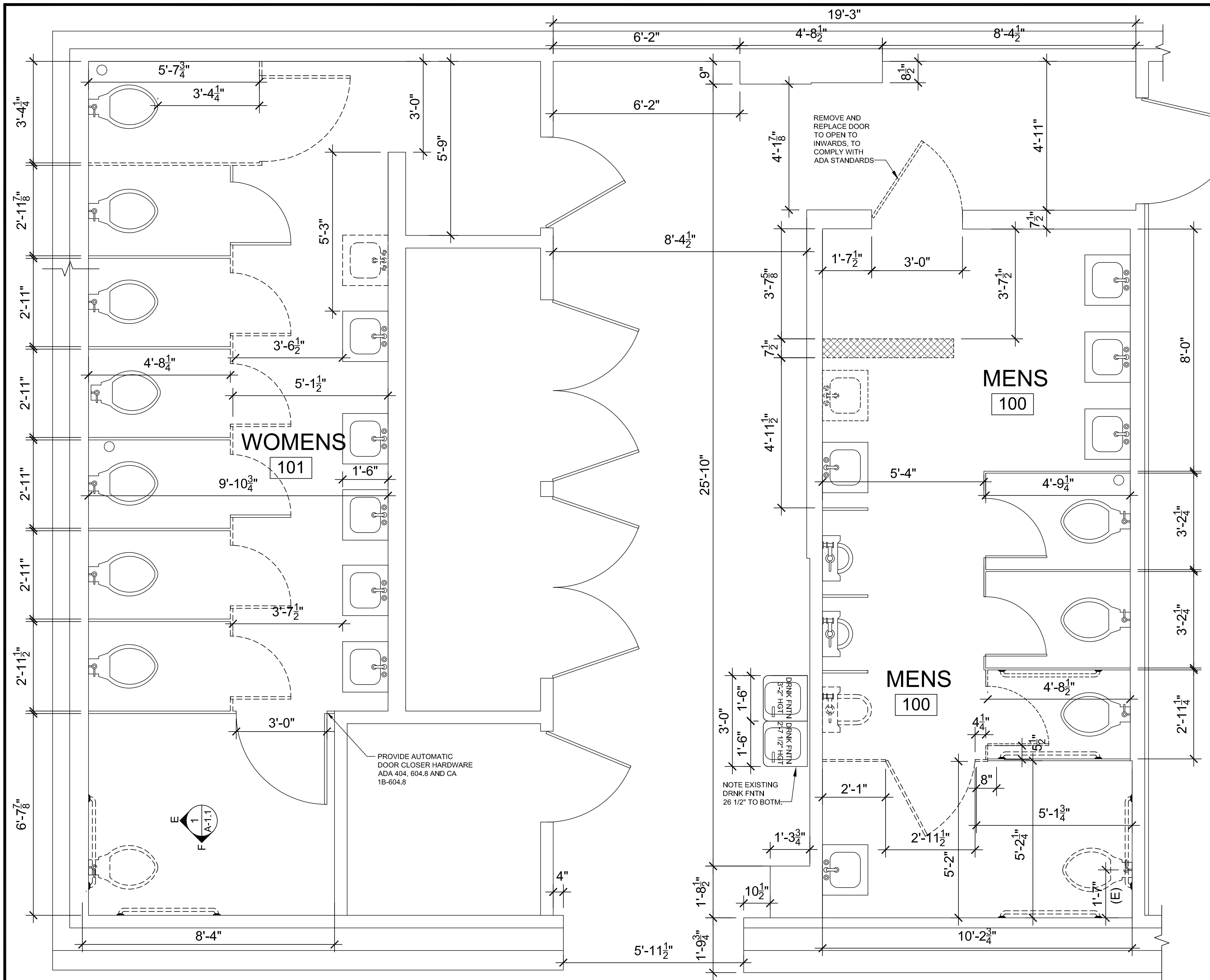

- ### GENERAL NOTES
- INTERIOR DIMENSIONS ARE TO FACE OF FINISH MATERIAL UNLESS NOTED OTHERWISE
 - SEE MECHANICAL DRAWINGS FOR SPECIFIC HVAC REQUIREMENTS
 - SEE ELECTRICAL DRAWINGS FOR SPECIFIC REQUIREMENTS
 - SEE FINISH PLAN AND INTERIOR ELEVATIONS FOR DESCRIPTION ALL FINISHES
 - THE GENERAL CONTRACTOR SHALL COORDINATE THE VARIOUS TRADES WITH SPECIFIC VENDOR REQUIREMENTS
 - ALL GYPBOARD SHALL BE 5/8" TYPE "X", USE WRB GYPBOARD AT ALL TOILET ROOMS AND JANITOR CLOSETS
 - IN THE EVENT OF DISCREPANCY BETWEEN DRAWINGS AND ACTUAL CONDITIONS, THE GENERAL CONTRACTOR SHALL IMMEDIATELY NOTIFY THE ARCHITECT FOR RESOLUTION PRIOR TO PROCEEDING WITH WORK
 - THE CONTRACTOR SHALL PROVIDE CONTINUOUS 16 GA SHEET METAL BACKING AT ALL WALL MOUNTED EQUIPMENT, SINKS AND CABINETS
 - ANY ROOM THAT IS USED FOR AN ASSEMBLY PURPOSE SHALL HAVE THE OCCUPANT CAPACITY OF THE ROOM POSTED IN A CONSPICUOUS PLACE ON AN APPROVED SIGN NEAR THE MAIN EXIT OR EXIT DOORWAY (CBC 1004.3)
 - DELETED
 - ALL FIRE EXTINGUISHERS ARE RECESSED FIRE EXTINGUISHERS INSTALLED IN A 2X6 WALL

- ### ACCESSIBILITY NOTES
- FOR TACTILE ACCESSIBLE BUILDING ENTRANCE SIGNAGE, SEE DETAIL 1/A-1.1, COMPLY WITH CBC 11B-703
 - FOR ACCESSIBLE DOOR MANEUVERING CLEARANCES, SEE DETAIL 1A/A-1.1
 - FOR TACTILE RESTROOM SIGNAGE, SEE RESTROOM 1/A-1.1, COMPLY WITH CBC 11B-703 2022
 - PROVIDE ROOM IDENTIFICATION WITH RAISED CHARACTERS AND IN BRAILLE PER CBC 11B-703 CBC 2022
 - PROVIDE A LEVEL LANDING ON EACH SIDE OF A DOOR EXTENDING 60" ON DIRECTION OF DOOR SWING AND 48" IN OPPOSITE DIRECTION OF DOOR SWING, MEASURED WITH DOOR CLOSED (CBC 11B-404.2.4.1 2022)
 - MANEUVERING CLEARANCE AT SWING DOORS AND GATES SHALL COMPLY WITH CBC 11B-404.2.4.1 AND TABLE 11B-404.2.4.1 MANEUVERING CLEARANCE AT SLIDING DOORS, FOLDING DOORS AND DOORWAYS WITHOUT DOORS SHALL COMPLY WITH CBC 11B-404.2.4.2 RECESSED DOORS AND GATES SHALL COMPLY WITH CBC 11B-404.2.4.3
 - PROVIDE SEATSPACES FOR PEOPLE USING WHEELCHAIRS IN ACCORDANCE WITH TABLE 11B-221.2.1, SPECIALTY SEATING AREAS AND INTEGRATION SHALL COMPLY WITH CBC 11B-221.2.1.6 & 11B-221.2.2
 - WHERE PROVIDED, AT LEAST ONE OF EACH TYPE OF SALES AND/OR SERVICE COUNTER SHALL COMPLY WITH CBC 11B-904.4 & 11B-227.3

NOTE:
SEE DETAIL A-1.1/2 FOR FIXTURES AND ACCESSORY MOUNTING HEIGHTS

NOTE:
ALL FINISHES TO MATCH EXISTING, VERIFY WITH OWNER.

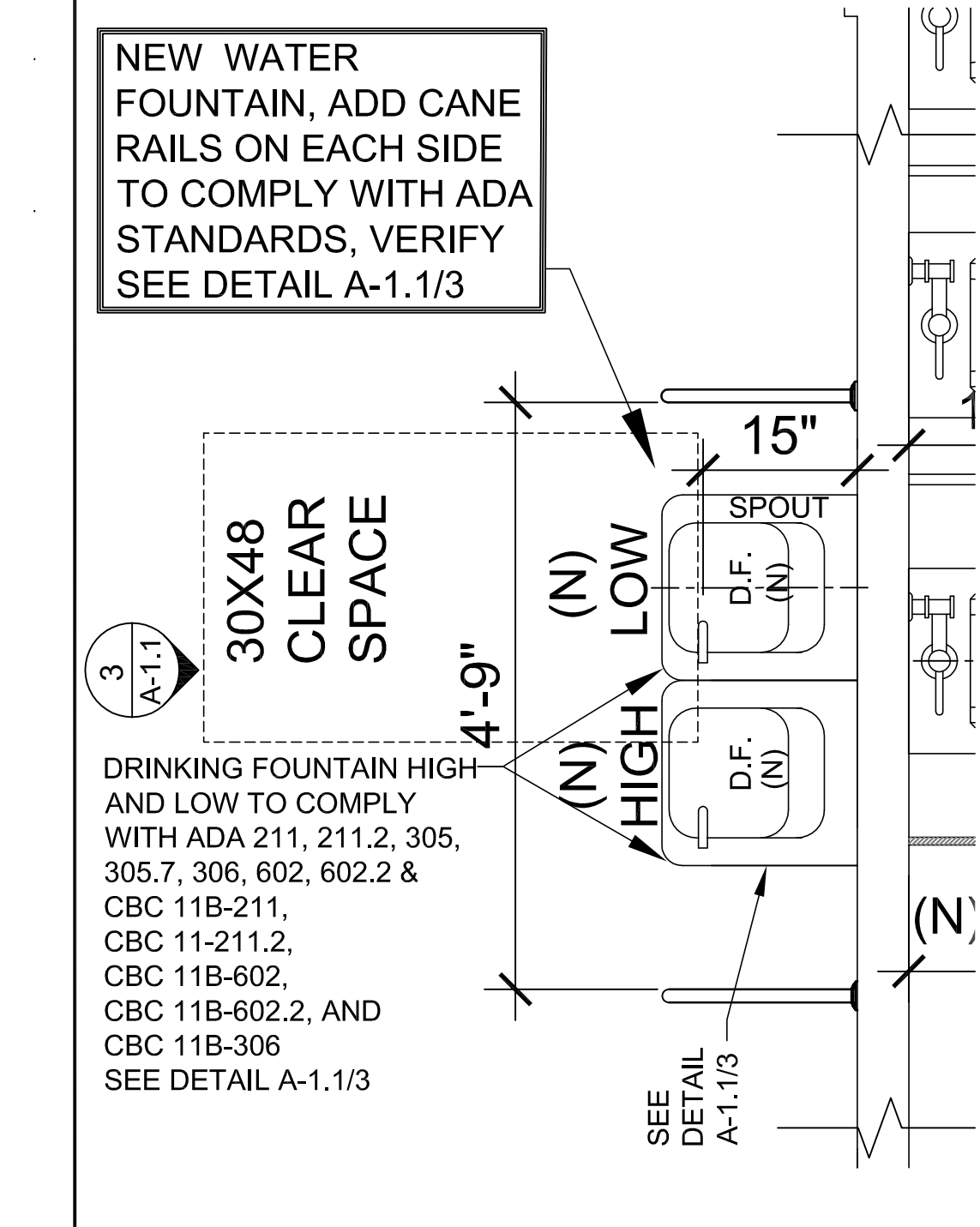

EXISTING AND DEMO PLAN

SCALE 1/2"=1'-0" A

NEW DRINKING FOUNTAIN WITH CANE RAILS ADDED

SCALE 3/4"=1'-0" E

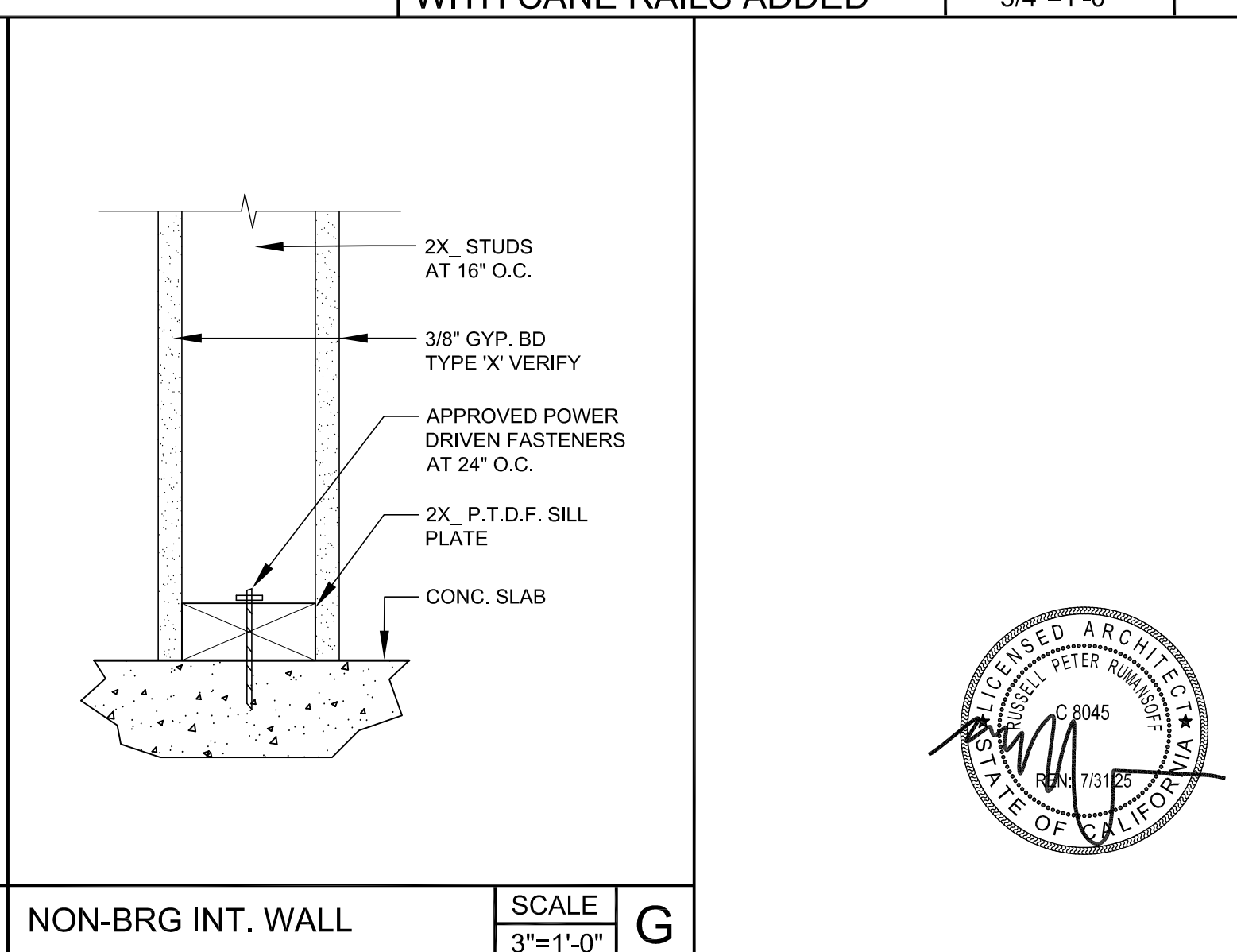
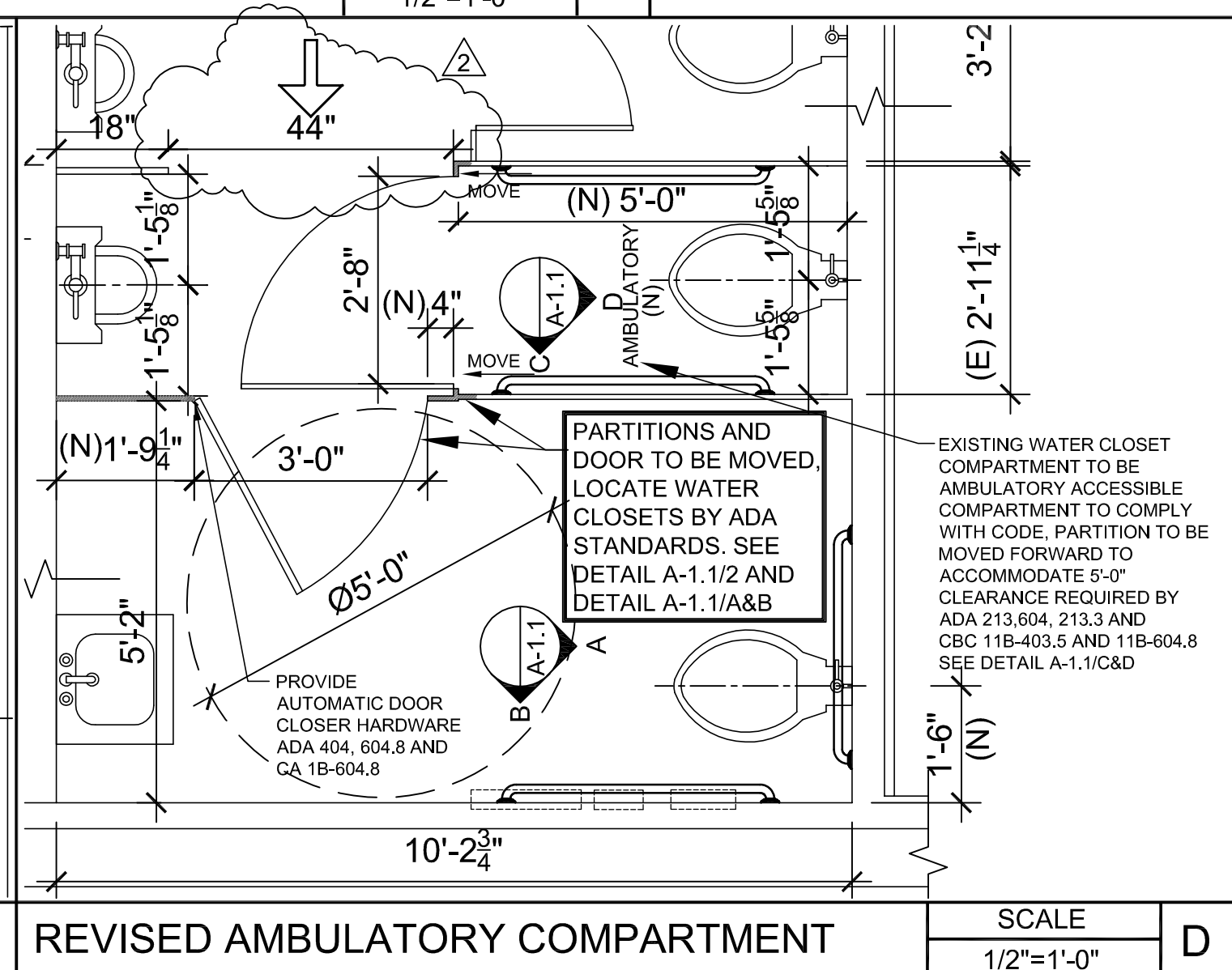
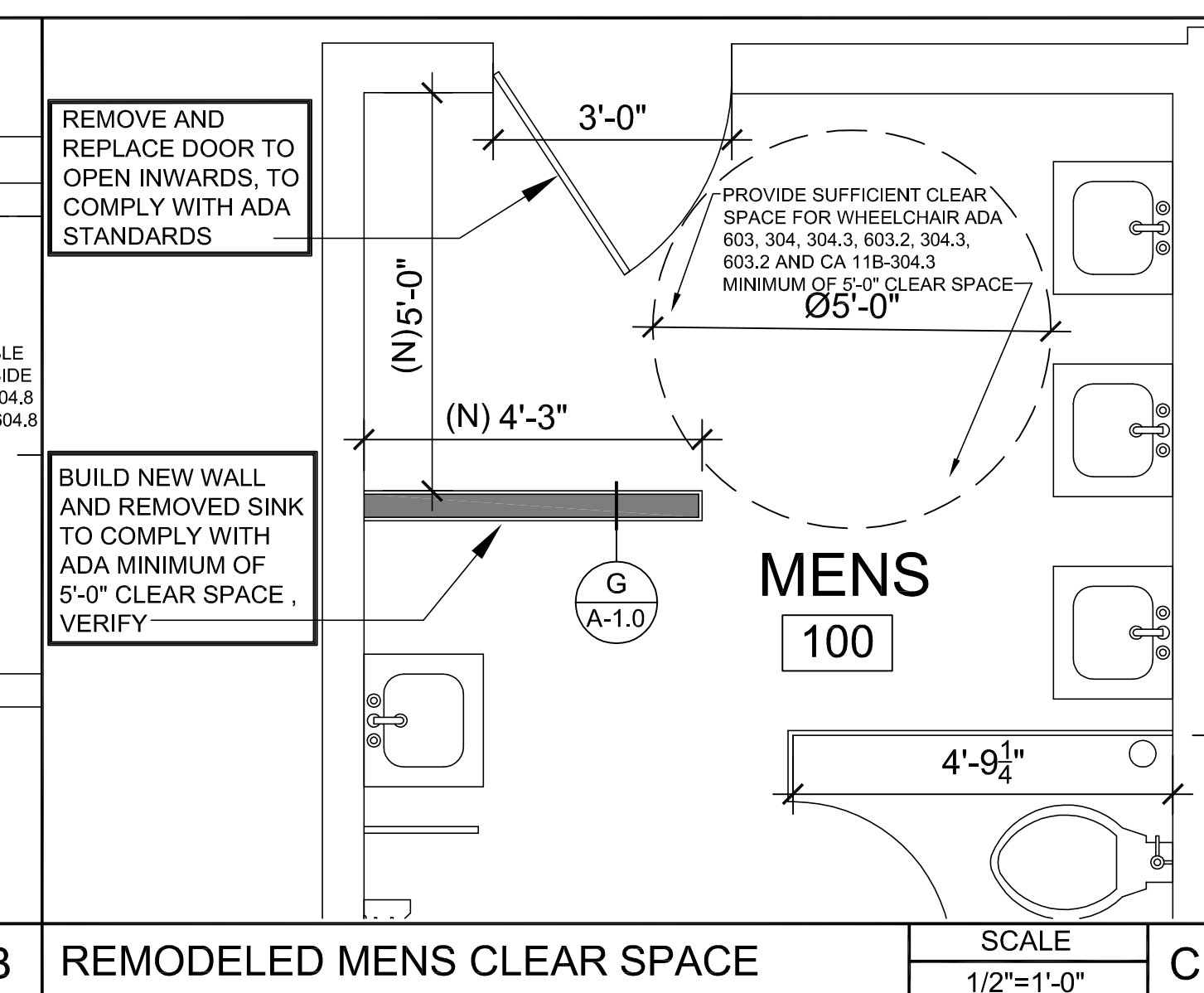
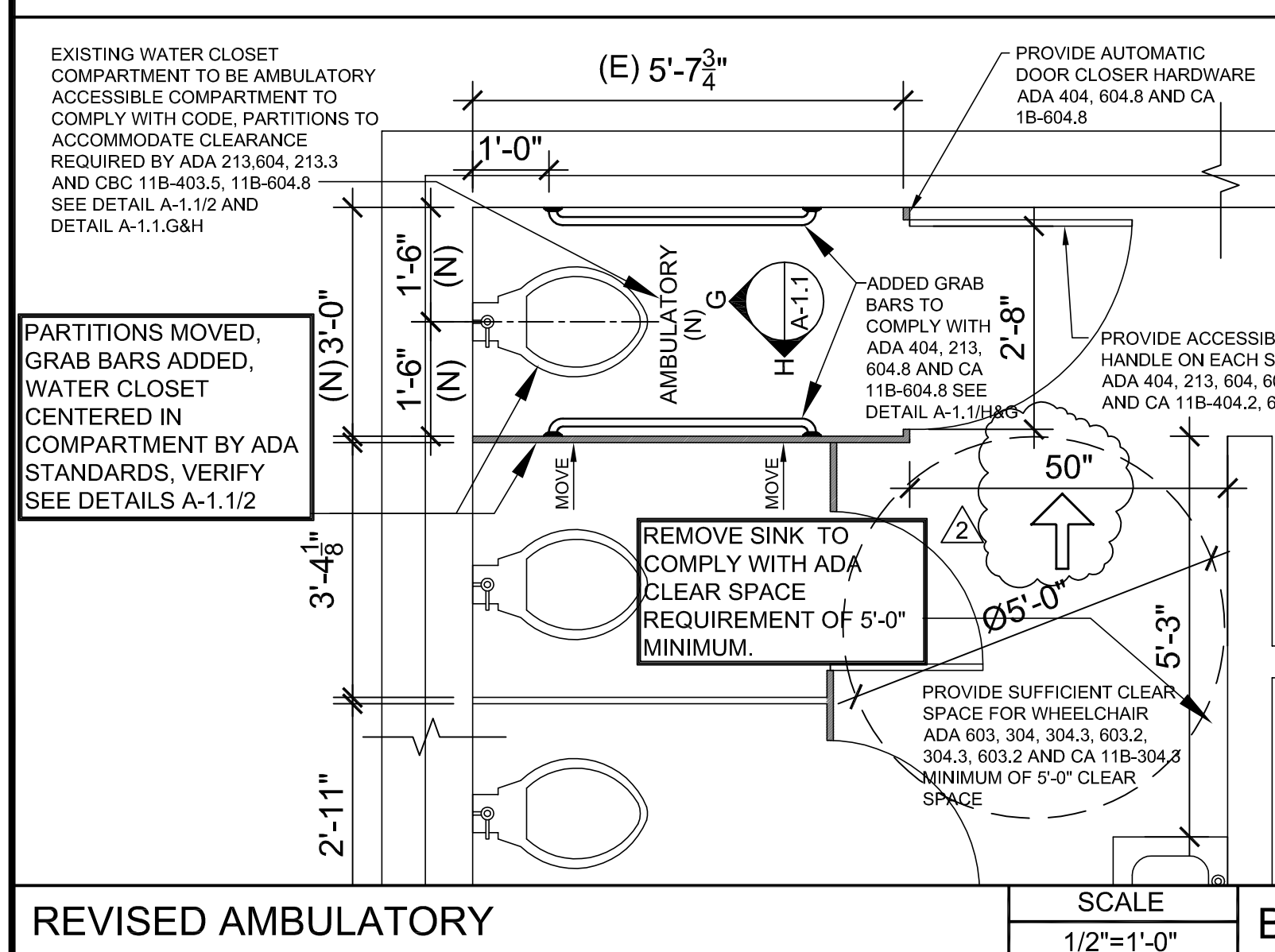

REVISED AMBULATORY

SCALE 1/2"=1'-0" B

REMODELED MENS CLEAR SPACE

SCALE 1/2"=1'-0" C

REVISED AMBULATORY COMPARTMENT

SCALE 1/2"=1'-0" D

NON-BRG INT. WALL

SCALE 3"=1'-0" G

ALL IDEAS, DESIGNS, AND ARRANGEMENTS INDICATED OR REPRESENTED BY THESE DRAWINGS ARE THE PROPERTY OF HERRON-RUMANOFF ARCHITECTS, INC. AND CONSTITUTE THE ORIGINAL AND UNPUBLISHED WORK OF THE ARCHITECT AND ARE INTENDED TO BE USED IN CONNECTION WITH THIS SPECIFIC PROJECT ONLY. NO COPYING, REPRODUCTION OR REUSE OF THESE DRAWINGS IS PERMISSIBLE WITHOUT THE WRITTEN CONSENT OF HERRON-RUMANOFF ARCHITECTS, INC.

HERRON RUMANOFF
 architects, inc.

PROJECT: WINCHESTER PARK AND FRANCIS DOMENIGONI COMMUNITY CENTER
 32655 HADDOCK STREET WINCHESTER, CA 92596

CONSULTANT: 951 652-4431

| 10-21-22 | 10-21-22 | 10-21-22 |
|----------|---------------|---------------|
| 01-13-23 | 1ST SKETCH | 1ST SKETCH |
| 04-17-23 | CLIENT REVIEW | CLIENT REVIEW |
| 06-15-23 | P.C.#2/2 | DATE |
| 08-21-23 | P.C.#3/3 | ISSUE PURPOSE |

ARCHITECT'S SIGNATURE: _____

SHEET NO. A-1.0

JOB NO. 106-33-22

EXISTING AND REVISED FLOOR PLANS

LICENSED ARCHITECT
 HERON RUMANOFF
 STATE OF CALIFORNIA
 C 8045
 FEB 7/31/25

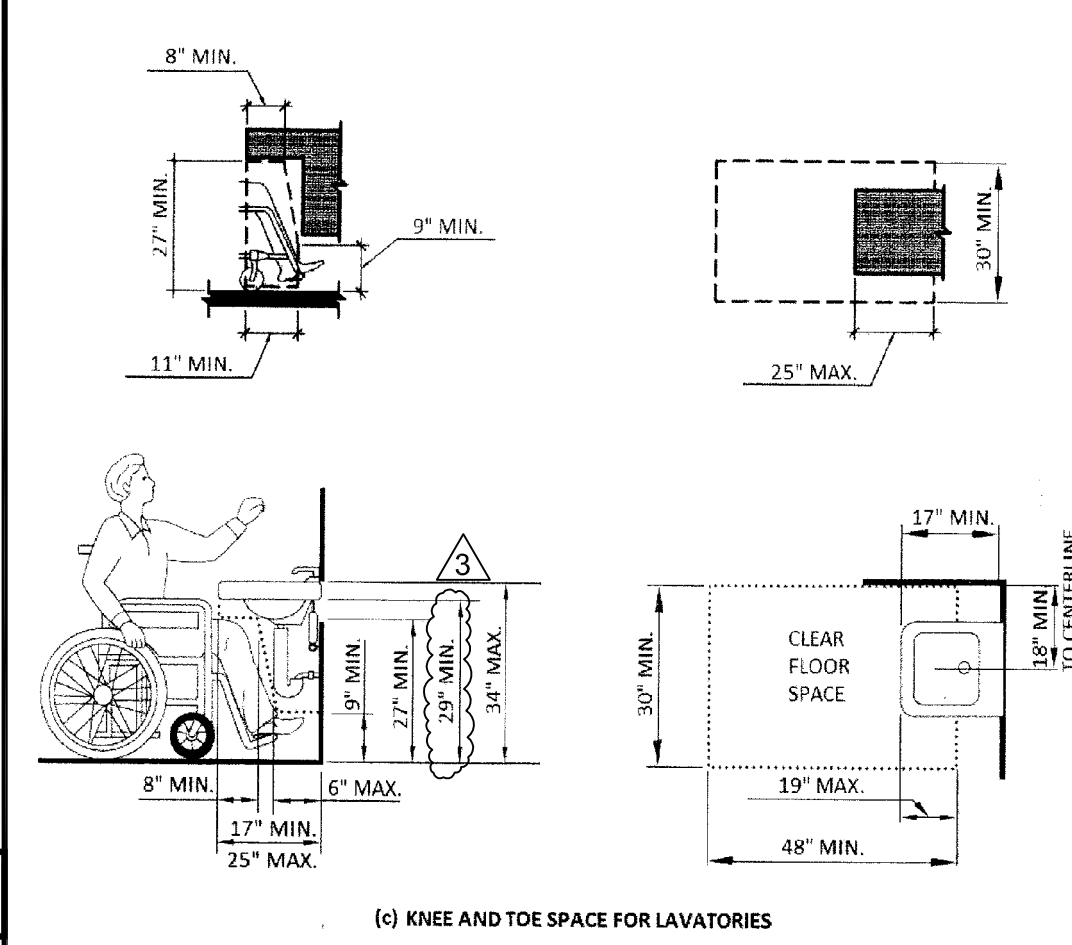
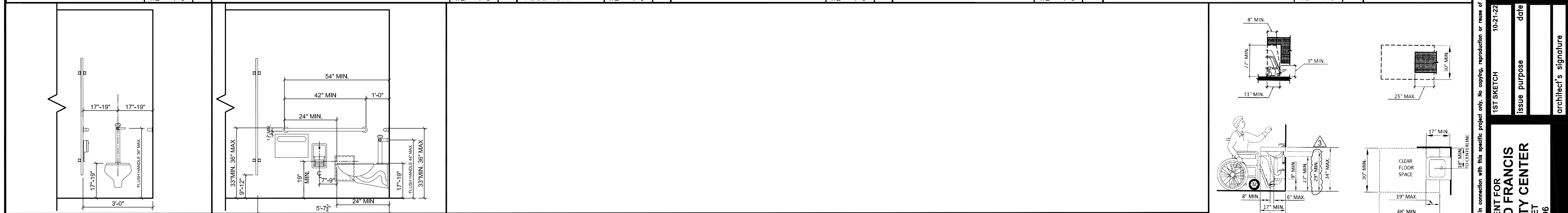
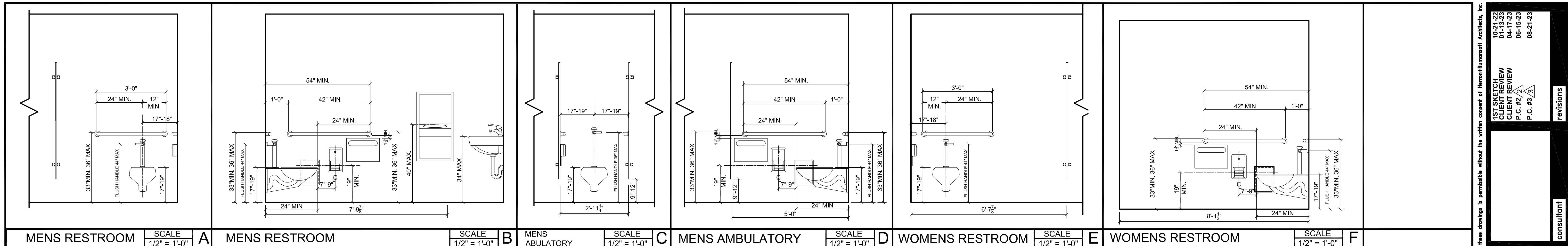
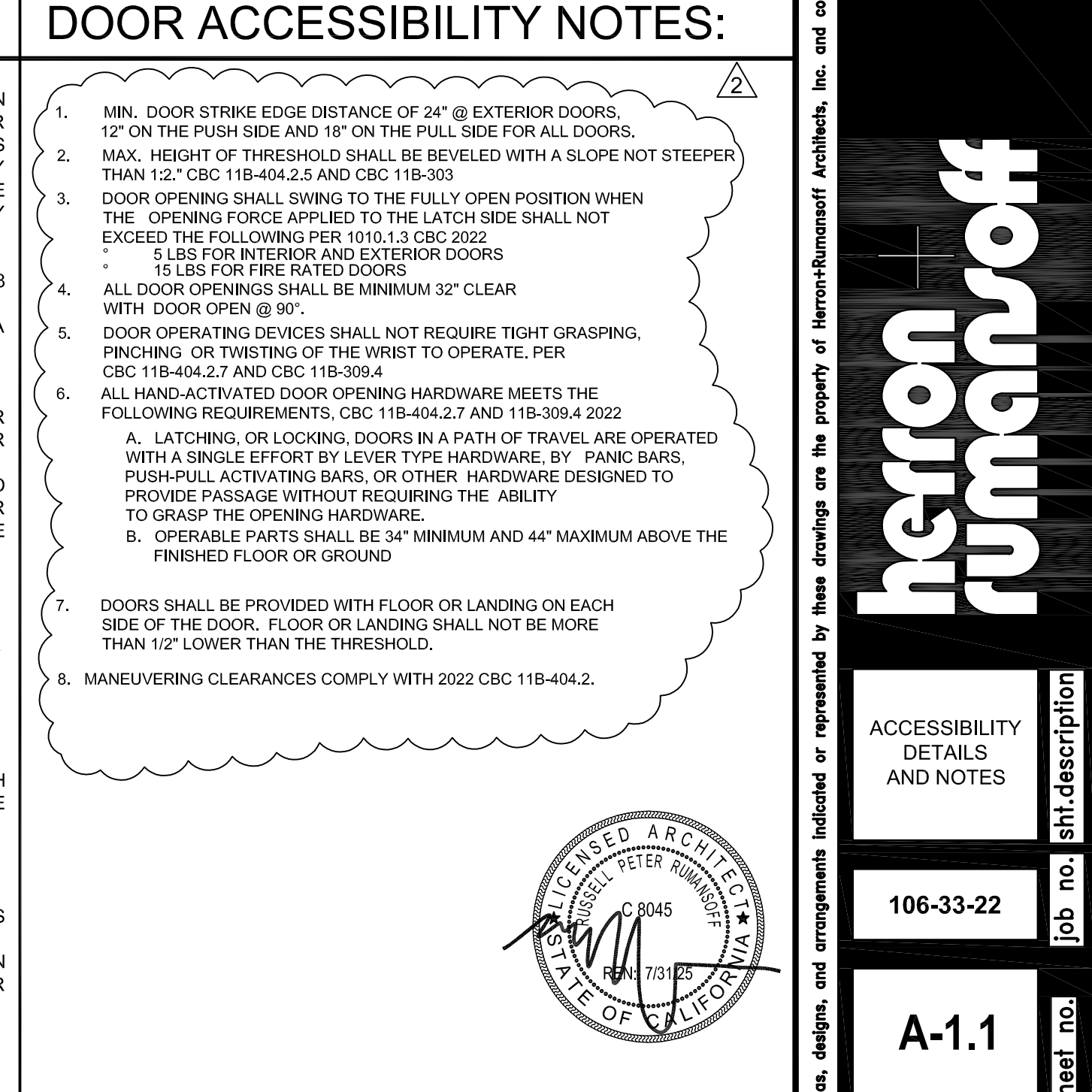
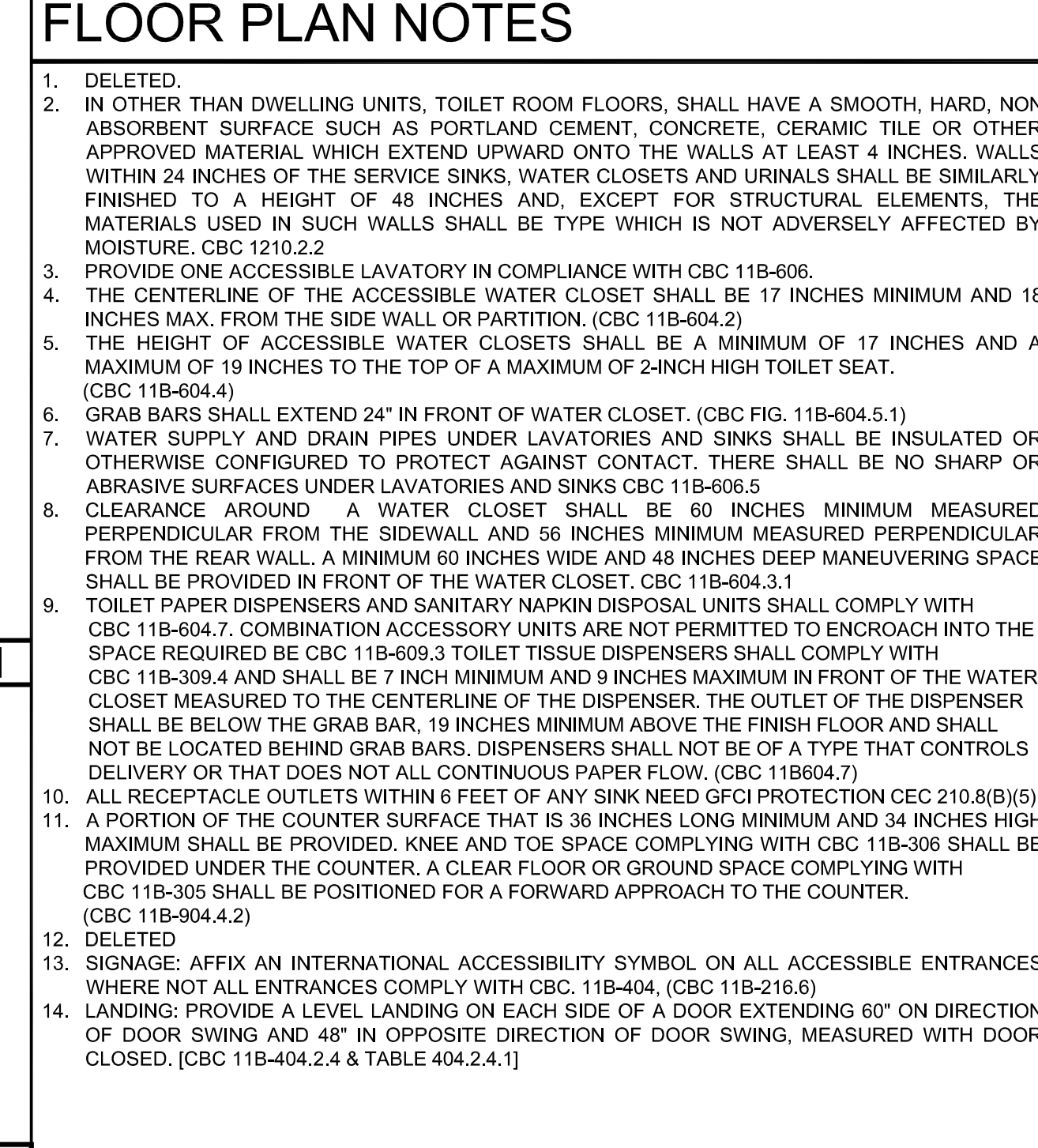
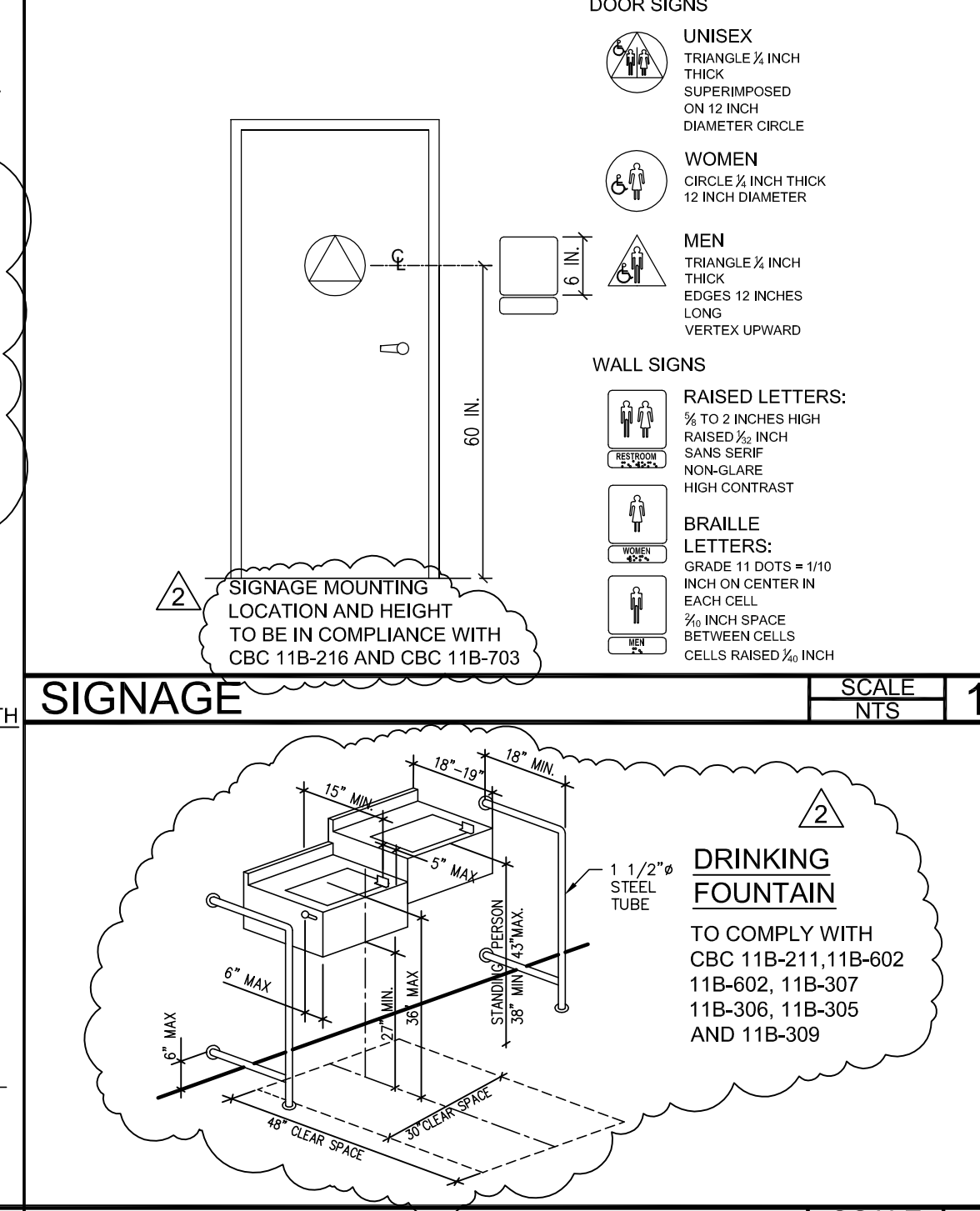
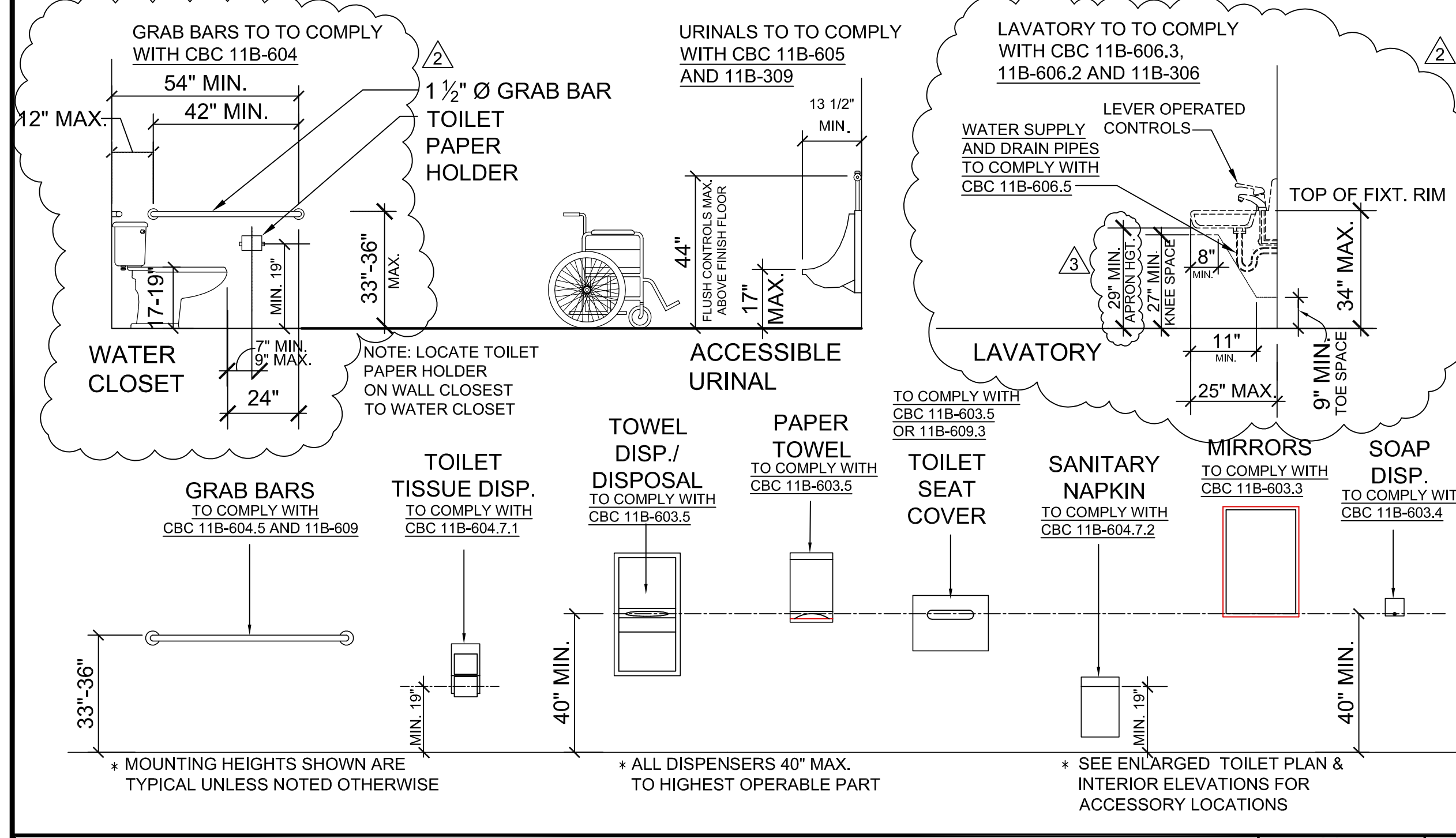
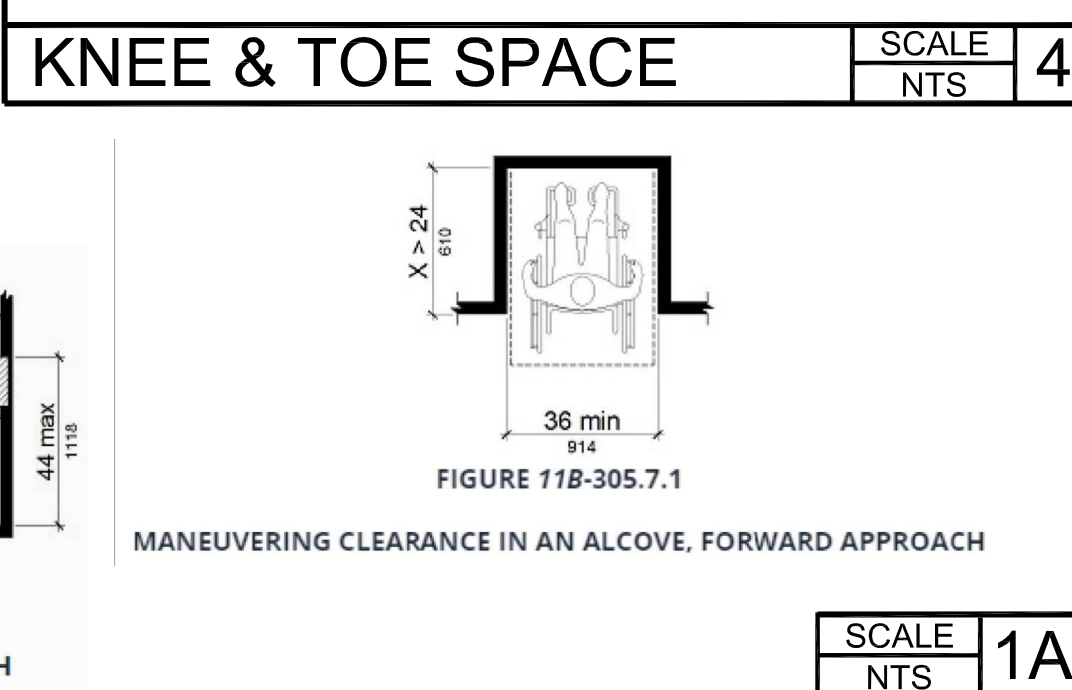
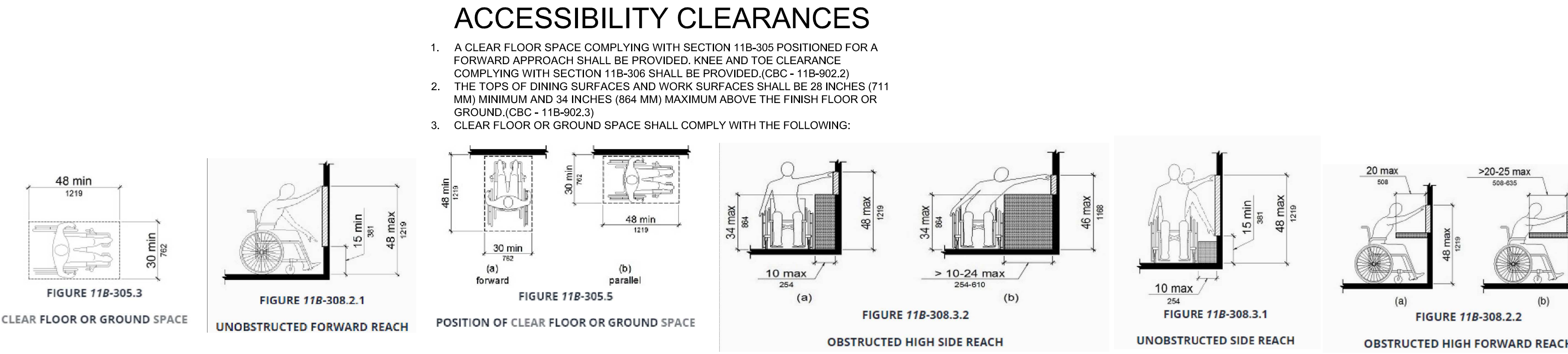

TABLE 11B-404.2.1
MANEUVERING CLEARANCES AT MANUAL SWINGING DOORS AND GATES

| TYPE OF USE | MINIMUM MANEUVERING CLEARANCE | |
|-----------------|----------------------------------|--|
| | Perpendicular to doorway | Parallel to doorway (beyond latch side unless noted) |
| From front | 60 inches (1524 mm) | 18 inches (457 mm) ¹ |
| From front | 48 inches (1219 mm) | 0 inches (0 mm) ² |
| From hinge side | 60 inches (1524 mm) | 36 inches (914 mm) |
| From hinge side | 44 inches (1118 mm) ³ | 22 inches (559 mm) ³ |
| From latch side | 60 inches (1524 mm) | 24 inches (610 mm) |
| From latch side | 44 inches (1118 mm) ³ | 24 inches (610 mm) |

1. Add 12 inches (305 mm) if closer and latch are provided.
 2. Add 4 inches (102 mm) if closer and latch are provided.
 3. Beyond hinge side.
 4. Add 4 inches (102 mm) if closer is provided.
 5. Add 6 inches (152 mm) at exterior side of exterior doors.



HERON RUMANOFF ARCHITECTS, INC.
 32655 HADDOCK STREET
 WINCHESTER, CA 92596

PROJECT: ACCESSIBILITY IMPROVEMENT FOR WINCHESTER PARK AND FRANCIS DOMENIGONI COMMUNITY CENTER

DATE: 10-21-22

ISSUE PURPOSE: 1ST SKETCH

REVISIONS:

| | |
|----------|---------------|
| 01-17-23 | CLIENT REVIEW |
| 04-17-23 | CLIENT REVIEW |
| 06-15-23 | P.C. #2 |
| 08-21-23 | P.C. #3 |

951 652-4431

ACCESSIBILITY IMPROVEMENT FOR VALLEY-WIDE RECREATION PARK DISTRICT

WINCHESTER PARK AND FRANCIS DOMENIGONI COMMUNITY CENTER

32655 HADDOCK STREET
WINCHESTER, CA.92596

ACCESSIBILITY NOTES

1. THE CLEAR WIDTH OF WALKING SURFACES SHALL BE 36" MIN. THE CLEAR WIDTH FOR WALKING SURFACES IN CORRIDORS SERVING AN OCCUPANT LOAD OF 10 OR MORE SHALL BE 44" MIN. THE CLEAR WIDTH FOR SIDEWALKS SHALL BE 48". 11B-403.5.1
2. OPERABLE PARTS ON ACCESSIBLE ELEMENTS, ROUTES, ROOMS AND SPACES SHALL COMPLY WITH SECTION 11B-309. OPERABLE PARTS SHALL BE OPERABLE WITH ONE HAND AND SHALL NOT REQUIRE TIGHT GRASPING, PINCHING OR TWISTING OF THE WRIST. THE FORCE REQUIRED TO ACTIVATE OPERABLE PARTS SHALL BE 5 POUNDS MAX. OPERABLE PARTS THAT ARE INTENDED FOR USE ONLY BY SERVICE OR MAINTENANCE PERSONNEL SHALL NOT BE REQUIRED TO COMPLY.
3. CLEAR FLOOR SPACE COMPLYING WITH SECTION 11B-305.7 THAT ALLOWS A FORWARD OR PARALLEL APPROACH BY A PERSON USING A WHEELCHAIR SHALL BE PROVIDED AT CONTROLS, DISPENSERS, RECEPTACLES, AND OTHER OPERABLE EQUIPMENT.
4. THE HIGHEST AND LOWEST OPERABLE PART OF ALL CONTROLS, DISPENSERS, RECEPTACLES, AND OTHER OPERABLE EQUIPMENT SHALL BE PLACED WITHIN ONE OF THE REACH RANGES SPECIFIED IN SECTIONS 11B-308.
5. ELECTRICAL AND COMMUNICATION SYSTEM RECEPTACLES ON BRANCH CIRCUITS OF 30 AMPERES OR LESS SHALL COMPLY WITH 11B-308 EXCEPT THE LOW REACH SHALL BE MEASURED TO THE BOTTOM OF THE OUTLET BOX AND THE HIGH REACH SHALL BE MEASURED TO THE TOP OF THE OUTLET BOX. FOR FORWARD (11B-308.2.1) AND SIDE (11B-308.3) REACH, THE LOW REACH IS 15" MIN. AND THE HIGH REACH IS 48" MAX. WHEN REACH IS OBSTRUCTED, E.G. @CABINETS THE HIGH REACH IS REDUCED TO 46" MAX. (11B-308.3.2)
6. ACCESSIBLE LAVATORIES SHALL COMPLY WITH 11B-606. FAUCETS CONTROLS AND OPERATING MECHANISMS SHALL COMPLY WITH 11B-309. CONTROLS SHALL BE OPERABLE WITH ONE HAND AND SHALL NOT REQUIRE GRASPING, PINCHING, OR TWISTING OF THE WRIST. THE FORCE REQUIRED TO ACTIVATE FAUCET CONTROLS AND OPERATING MECHANISMS SHALL BE NO GREATER THAN 5 LBF. LEVER-OPERATED, PUSH-TYPE, AND ELECTRONICALLY CONTROLLED MECHANISMS ARE EXAMPLES OF ACCEPTABLE DESIGNS. SELF-CLOSING VALVES ARE ALLOWED IF THE FAUCET REMAINS OPEN FOR AT LEAST 10 SECONDS.
7. EMPLOYEE WORKSTATIONS SHALL BE ON AN ACCESSIBLE ROUTE COMPLYING WITH DIVISION 4. SPACES AND ELEMENTS WITHIN EMPLOYEE WORKSTATIONS SHALL ONLY BE REQUIRED TO COMPLY WITH SECTIONS 11B-207.1, 11B-215.3, 11B-302 11B-303 AND 11B404.2.3. COMMON USE CIRCULATION PATHS WITHIN EMPLOYEE WORKSTATIONS SHALL COMPLY WITH SECTION 11B-206.2.8.
8. IF SEATING SPACES FOR PERSONS IN WHEELCHAIRS IS PROVIDED AT FIXED TABLES OR COUNTERS, CLEAR FLOOR SPACE COMPLYING WITH SECTION 11B-305 SHALL BE PROVIDED. KNEE CLEARANCE SHALL EXTEND 25" MAX. UNDER AN ELEMENT AT 9" ABOVE THE FINISH FLOOR OR GROUND (11B-306.3). THE TOPS OF TABLES AND COUNTERS SHALL BE 34" MAX. FROM THE FLOOR OR GROUND. (11B-304)
9. IF THE BUILDING INSPECTOR DETERMINES NONCOMPLIANCE WITH ANY CURRENT ACCESSIBILITY PROVISION OF THE LAW, HE/SHE SHALL REQUIRE SUBMITTAL OF COMPLETE AND DETAILED PLANS TO THE PLANNING AND BUILDING DEPARTMENT FOR FURTHER REVIEW. PLANS MUST CLEARLY SHOW ALL EXISTING NON-CONFORMING CONDITIONS AFFECTED BY THE REMODEL (INCLUDING SITE PLAN, FLOOR PLANS, DETAILS, ETC.) AND PROPOSED MODIFICATIONS OF THE DEFICIENCIES TO MEET CURRENT ACCESSIBILITY PROVISIONS.
10. MAXIMUM EFFORT TO OPERATE EXTERIOR AND INTERIOR DOORS SHALL NOT EXCEED 5 POUNDS, WITH SUCH PULL OR PUSH EFFORT BEING APPLIED AT RIGHT ANGLES TO HINGED DOORS AND AT THE CENTER PLANE OF SLIDING OR FOLDING DOORS. COMPENSATING DEVICES OR AUTOMATIC DOOR OPERATORS MAY BE UTILIZED TO MEET THE ABOVE STANDARDS (11B-404.2.9). EXISTING EXTERIOR DOORS SHALL COMPLY WITH THE ABOVE REQUIREMENT. IF THE EXISTING EXTERIOR DOORS DO NOT COMPLY, THEY SHALL BE RETROFIT AS PART OF THIS PERMIT.

PROJECT DIRECTORY

| | |
|--|---|
| OWNER: VALLEY WIDE RECREATION AND PARK DISTRICT 901 WEST ESPLANADE AVENUE SAN JACINTO, CA 92383 | ARCHITECT: HERRON + RUMANSOFF ARCHITECTS, INC. 530 ST. JOHN PLACE HEMET, CA 92543 CONTACT: RUSSELL RUMANSOFF (951) 652-4431 |
|--|---|

VICINITY MAP: N.T.S.



CODE SUMMARY:

| | |
|------------|---------------------|
| BUILDING | 2022 CBC |
| MECHANICAL | 2022 CMC |
| PLUMBING | 2022 CPC |
| ELECTRICAL | 2022 CEC |
| ENERGY | CALIFORNIA TITLE 24 |
| CAL GREEN | 2022 |
| FIRE | 2022 CFC |
| ADA | 2010 |

2010 ADA STANDARDS FOR ACCESSIBLE DESIGN

WITH STATE AND LOCAL AMENDMENTS
THE ABOVE ARE THE CODES/STANDARDS THAT ARE APPLICABLE TO THIS PROJECT

NOTE:

ALL NEW AND EXISTING FIXTURES AND ACCESSORIES TO COMPLY WITH 2022 CBC-11B MOUNTING HEIGHTS AND LOCATIONS. SEE DIMENSIONS ON FLOOR PLAN ON SHEET A-1.0 AND DETAILS ON SHEET A-1.1

FINISHES:

ALL FINISHES TO MATCH EXISTING, VERIFY WITH OWNER.

SCOPE OF WORK:

ALTERATIONS TO EXISTING RESTROOM FACILITY TO COMPLY WITH CA-11B ACCESSIBILITY CODE

SHEET INDEX

| NO. | SHEET | DESCRIPTION |
|-----|-------|----------------------------------|
| 1 | T-1.0 | TITLE SHEET, SITE PLAN |
| 2 | A-1.0 | EXISTING AND REMODEL FLOOR PLAN |
| 3 | A-1.1 | RESTROOM & ACCESSIBILITY DETAILS |

SITE / BUILDING DATA:

A.P.N.: 435-190-180
SITE ADDRESS: 32655 HADDOCK STREET
WINCHESTER, CA.92596

LEGAL DESCRIPTION:

(E) LAND USE: RECREATION BUILDING W/ GYMNASIUM
(E) ZONING:
LOT SIZE:
(E) BUILDING SIZE
NUMBER OF STORIES: 1
CONSTRUCTION TYPE: TYPE V-1 HOUR / SPRINKLERED
OCCUPANCY GROUP: U
PROPERTY CLASS: GYMNASIUM / RESTROOM FACILITY

OWNER: VALLEY WIDE RECREATION AND PARK DISTRICT 901 WEST
ESPLANADE AVENUE
SAN JACINTO, CA 92383

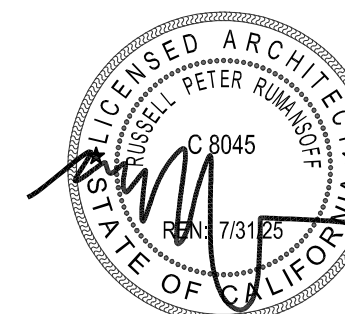

| | |
|----------|-----------------|
| 10-21-22 | 1ST SKETCH |
| 01-13-23 | CLIENT REVIEW |
| 04-17-23 | CLIENT REVIEW |
| 06-15-23 | P.C. #2 / 2 |
| 08-21-23 | P.C. #3 / 3 |
| 12-21-23 | H&R PLAN REVIEW |

| | |
|----------|---------|
| 10-21-22 | issue |
| | purpose |
| | date |

10-21-22
1ST SKETCH

ACCESSIBILITY IMPROVEMENT FOR
WINCHESTER PARK AND FRANCIS
DOMENIGONI COMMUNITY CENTER
32655 HADDOCK STREET
WINCHESTER, CA.92596

project

951 652-4431
consultant

architect's signature

revisions

12/21/2023 3:28:49 PM

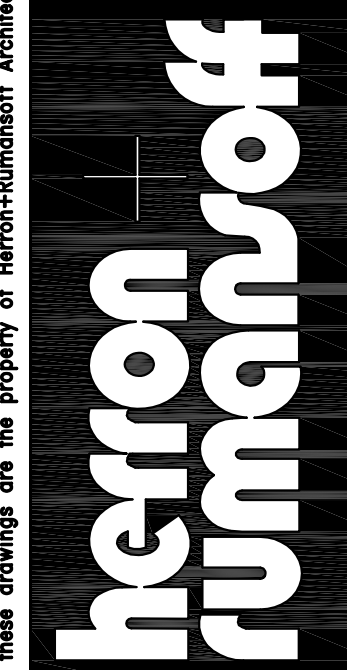

TITLE SHEET & SITE PLAN
106-33-22
T-1.0

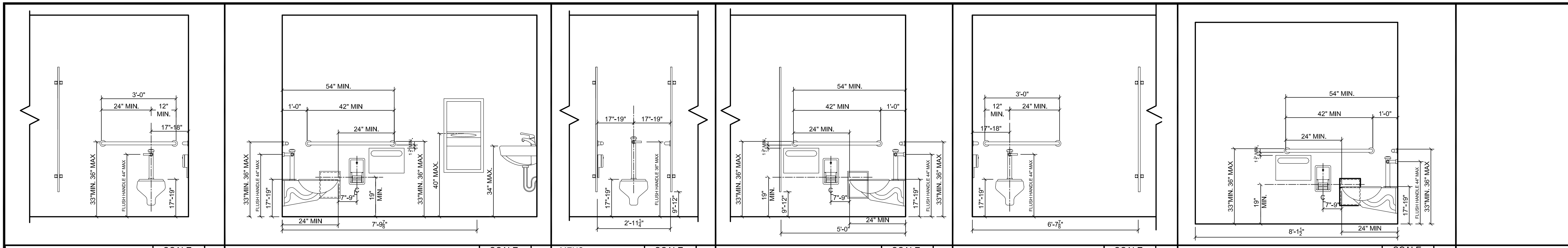

MENS RESTROOM SCALE 1/2" = 1'-0" A MENS RESTROOM SCALE 1/2" = 1'-0" B MENS AMBULATORY SCALE 1/2" = 1'-0" C MENS AMBULATORY SCALE 1/2" = 1'-0" D WOMENS RESTROOM SCALE 1/2" = 1'-0" E WOMENS RESTROOM SCALE 1/2" = 1'-0" F



WOMENS AMBULATORY SCALE 1/2" = 1'-0" G WOMENS AMBULATORY SCALE 1/2" = 1'-0" H

TABLE 11B-404.2.1
MANEUVERING CLEARANCES AT MANUAL SWINGING DOORS AND GATES

| Approach direction | Door or gate side | MINIMUM MANEUVERING CLEARANCE | |
|--------------------|-------------------|-------------------------------|--|
| | | Perpendicular to doorway | Parallel to doorway (beyond latch side unless noted) |
| From front | Pull | 60 inches (1524 mm) | 18 inches (457 mm) |
| From front | Push | 48 inches (1219 mm) | 0 inches (0 mm) |
| From hinge side | Pull | 60 inches (1524 mm) | 36 inches (914 mm) |
| From hinge side | Push | 44 inches (1118 mm) | 22 inches (559 mm) |
| From latch side | Pull | 60 inches (1524 mm) | 24 inches (610 mm) |
| From latch side | Push | 44 inches (1118 mm) | 24 inches (610 mm) |

1. Add 12 inches (305 mm) if closer and latch are provided.
 2. Add 4 inches (102 mm) if closer and latch are provided.
 3. Beyond hinge side.
 4. Add 4 inches (102 mm) if closer is provided.
 5. Add 6 inches (152 mm) at exterior side of exterior doors.

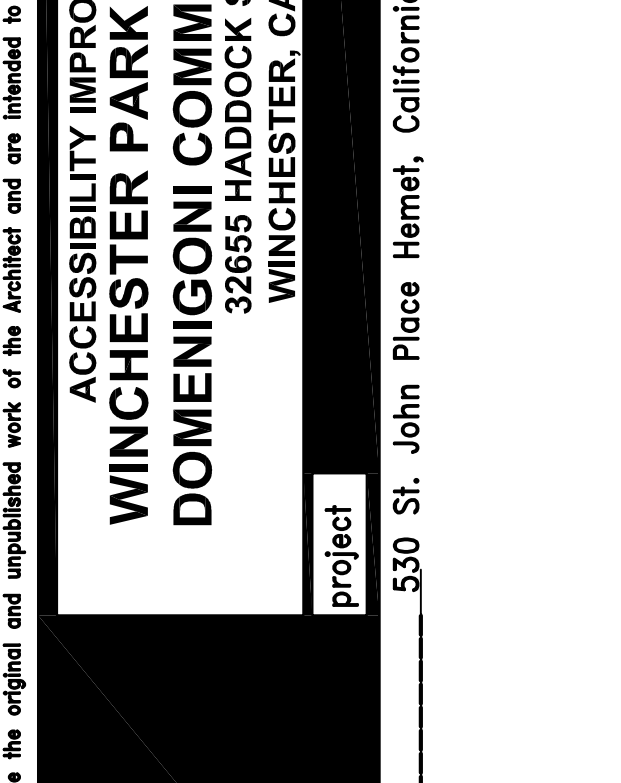
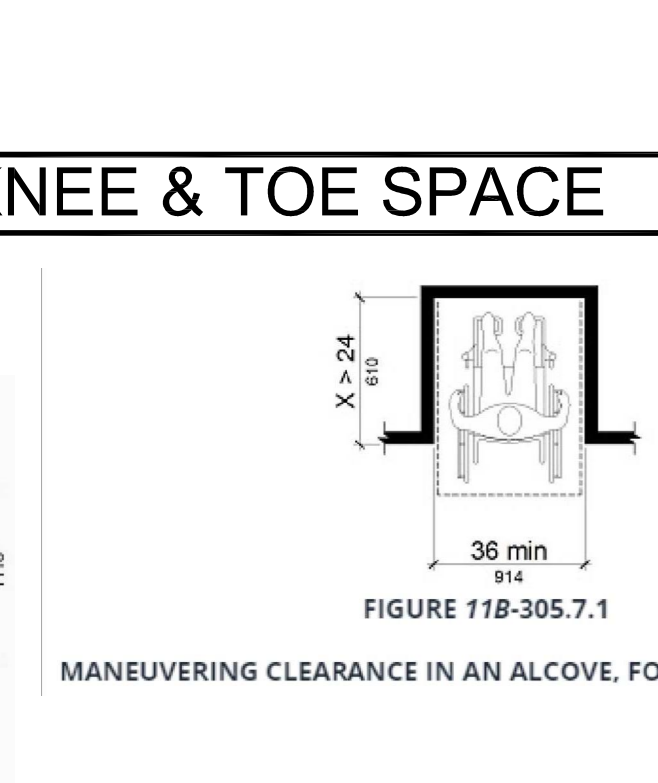
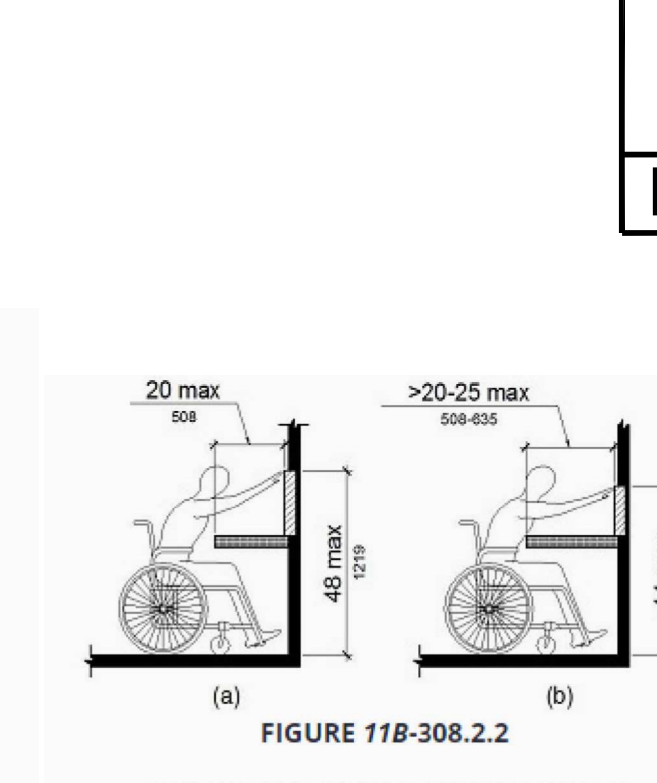
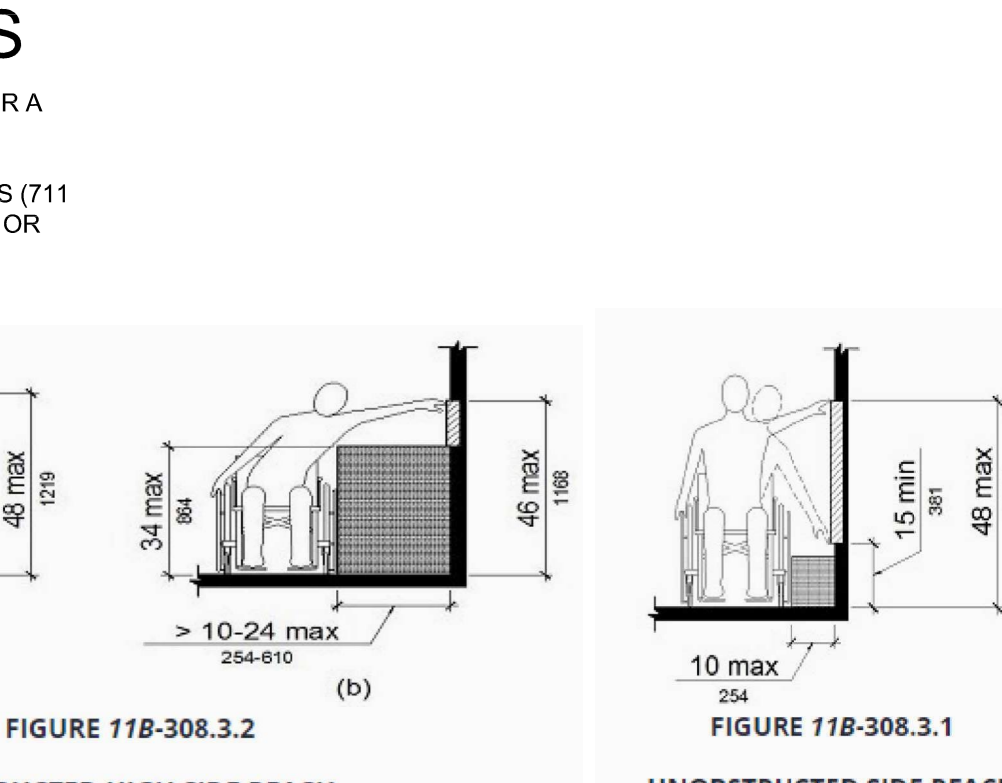
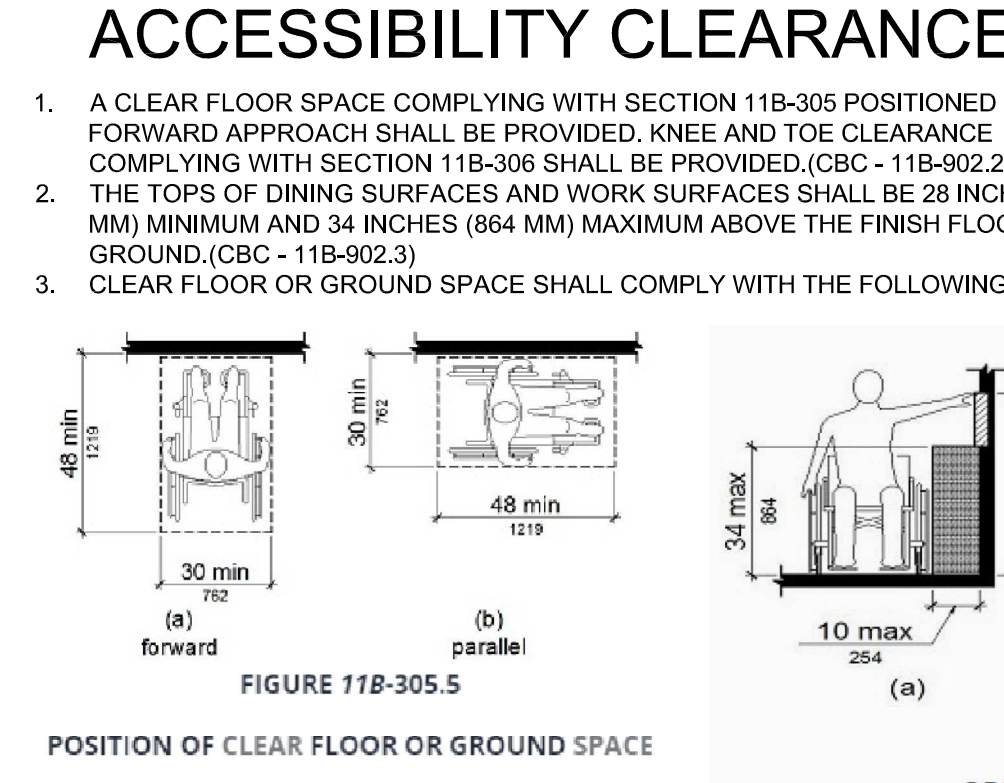
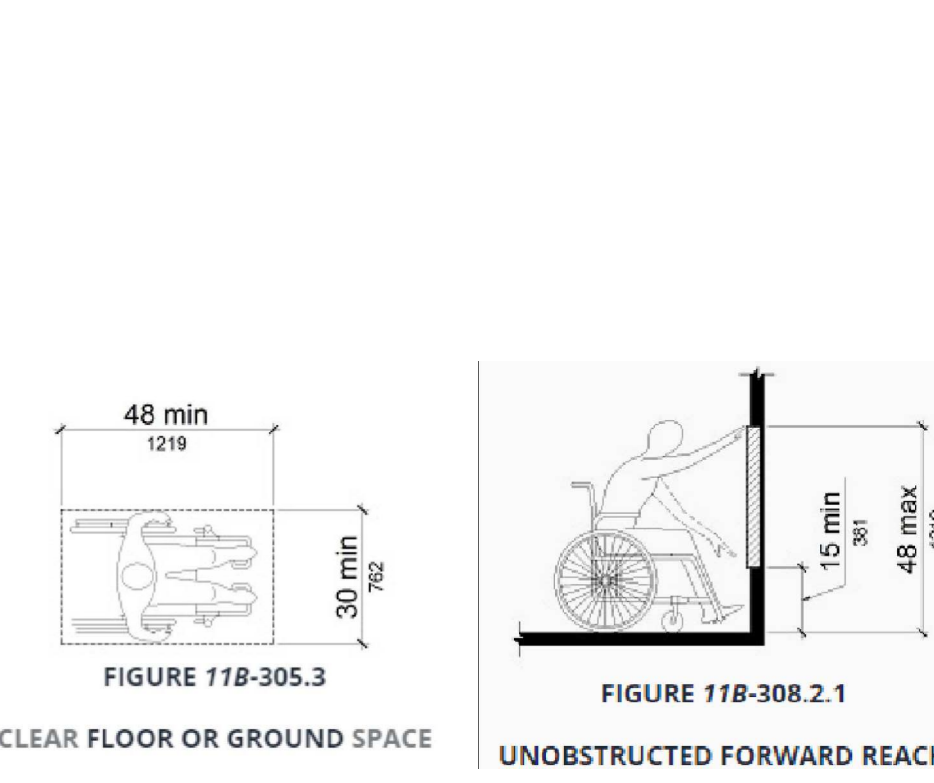

ACCESSIBILITY CLEARANCES

- A CLEAR FLOOR SPACE COMPLYING WITH SECTION 11B-305 POSITIONED FOR A FORWARD APPROACH SHALL BE PROVIDED. KNEE AND TOE CLEARANCE COMPLYING WITH SECTION 11B-306 SHALL BE PROVIDED. (CBC - 11B-902.2)
- THE TOPS OF DINING SURFACES AND WORK SURFACES SHALL BE 28 INCHES (711 MM) MINIMUM AND 34 INCHES (864 MM) MAXIMUM ABOVE THE FINISH FLOOR OR GROUND. (CBC - 11B-902.3)
- CLEAR FLOOR OR GROUND SPACE SHALL COMPLY WITH THE FOLLOWING:

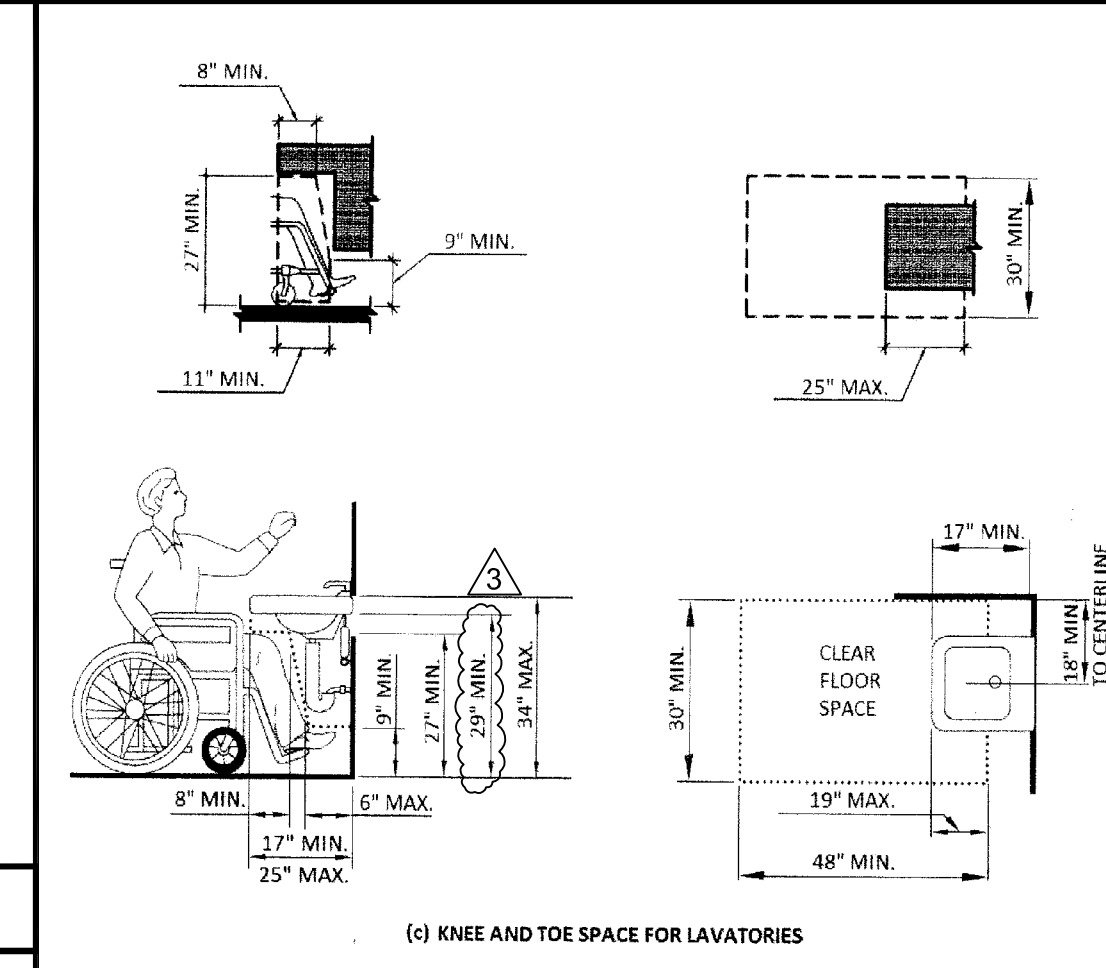

KNEE & TOE SPACE

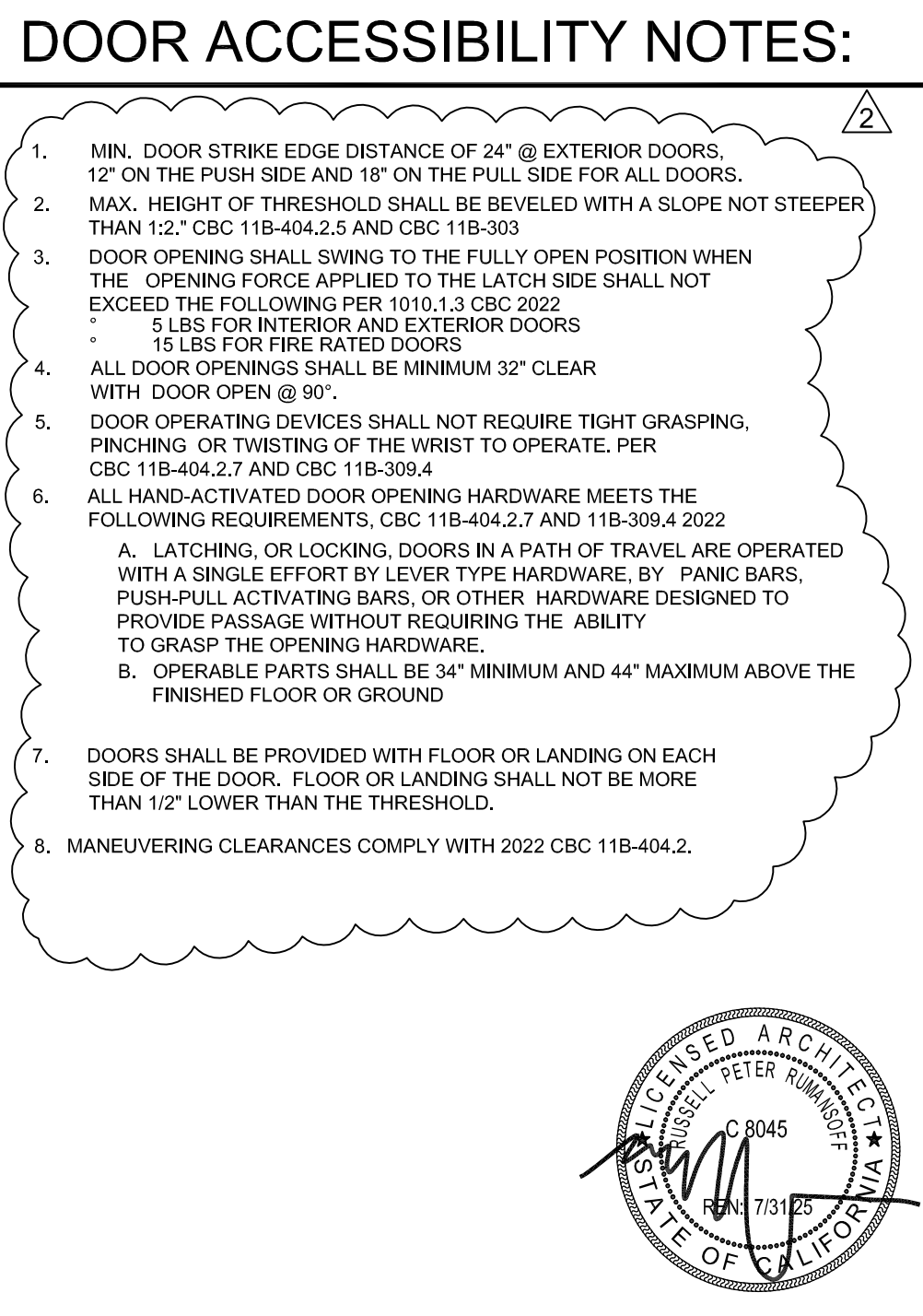
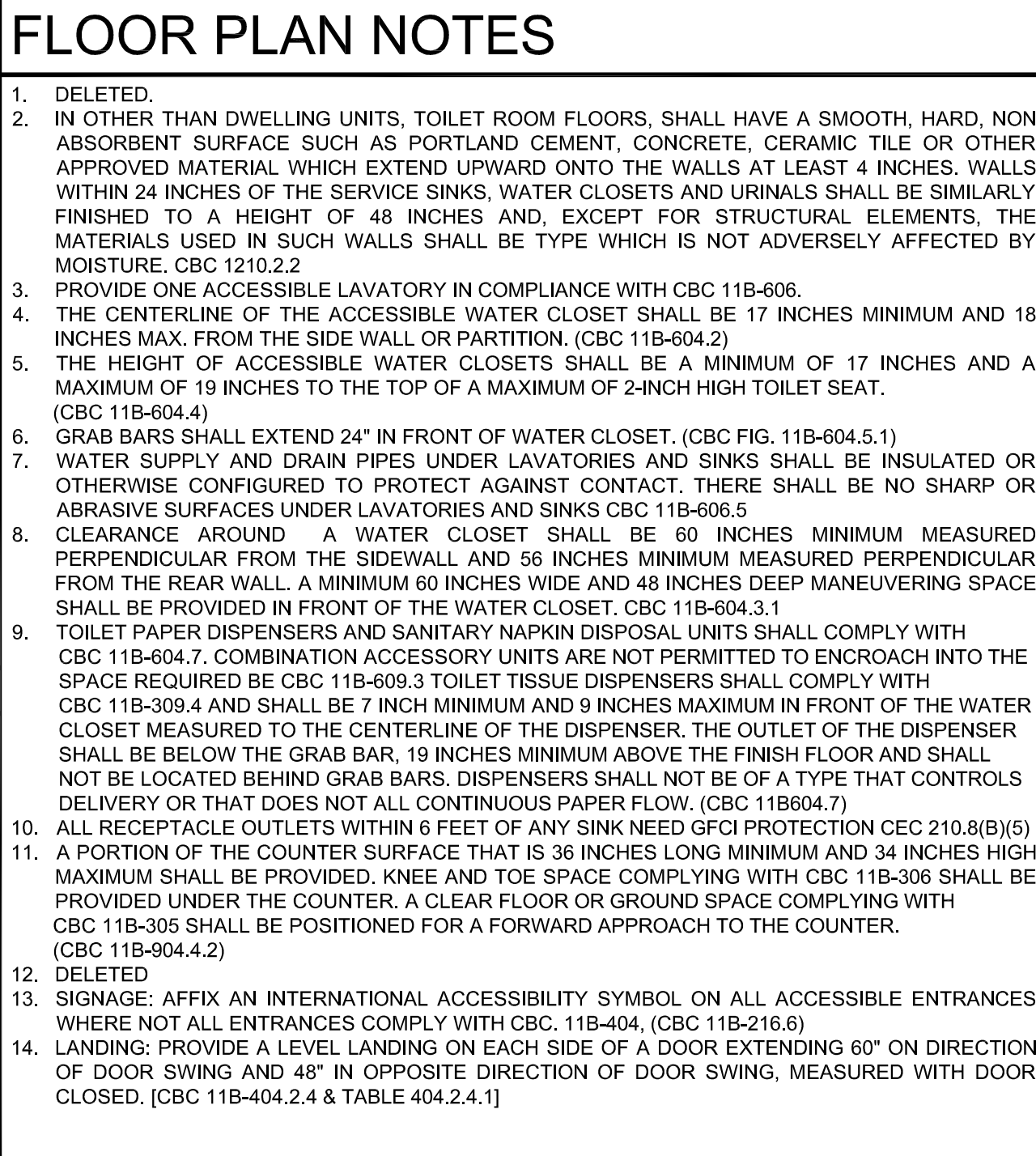
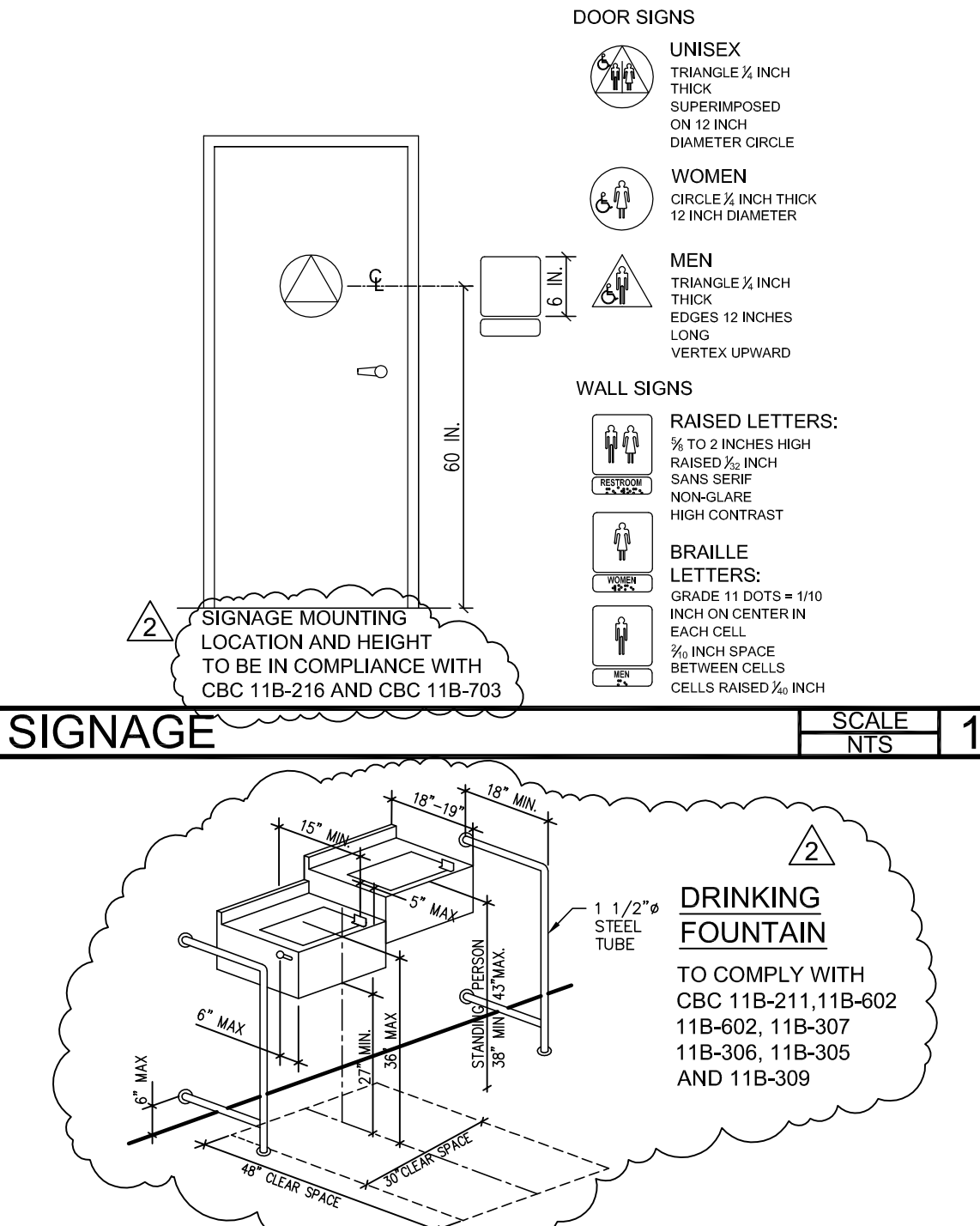
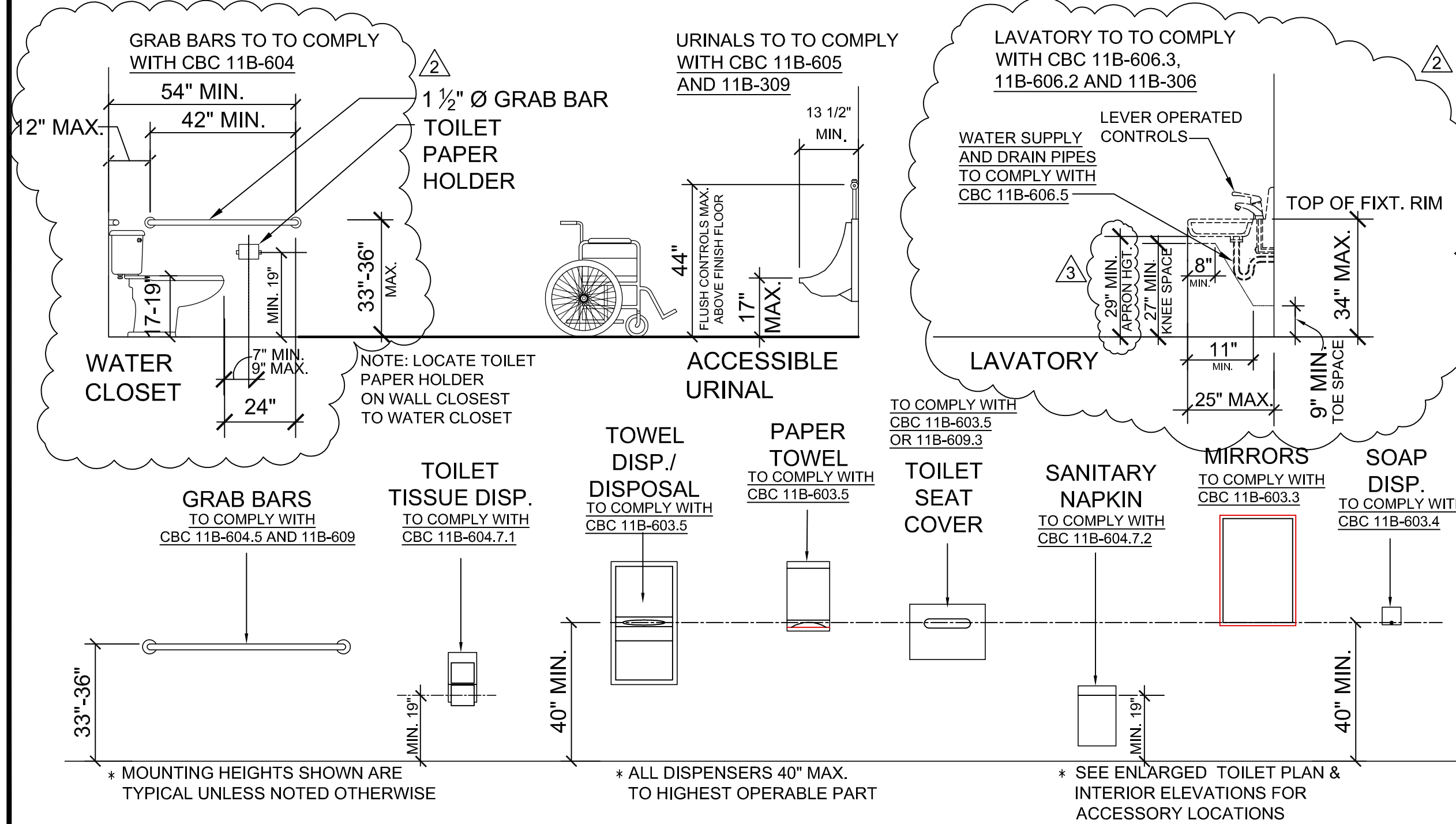
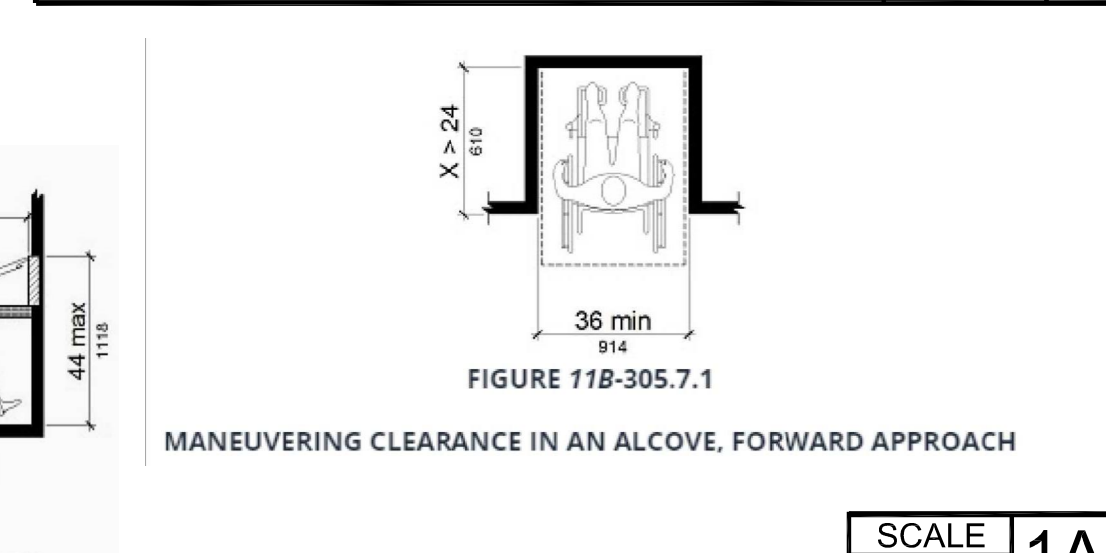

FIXTURE MOUNTING HEIGHTS SCALE NTS 2 DRINKING FOUNTAINS SCALE NTS 3

10-21-22
01-13-23
04-17-23
06-15-23
08-21-23
12-21-23

1ST SKETCH
CLIENT REVIEW
CLIENT REVIEW
P.C. #2
P.C. #3
M&R PLAN REVIEW

10-21-22
10-21-22
10-21-22
10-21-22

issue purpose
date
revisions

consultant
architect's signature

ACCESSIBILITY IMPROVEMENT FOR
WINCHESTER PARK AND FRANCIS
DOMENIGONI COMMUNITY CENTER
32655 HADDOCK STREET
WINCHESTER, CA 92596

project
950 St. John Place Hemet, California 92543

951 652-4451

heyrmansof architects, inc.

ACCESSIBILITY DETAILS AND NOTES
106-33-22
A-1.1

job no. shi.description
sheet no.

ALL IDEAS, DESIGNS, AND ARRANGEMENTS INDICATED OR REPRESENTED BY THESE DRAWINGS ARE THE PROPERTY OF HEYRON-HUMANOFF ARCHITECTS, INC. AND CONSTITUTE THE ORIGINAL AND UNPUBLISHED WORK OF THE ARCHITECT AND ARE NOT TO BE REPRODUCED OR TRANSMITTED IN ANY FORM OR BY ANY MEANS, ELECTRONIC OR MECHANICAL, INCLUDING PHOTOCOPYING, RECORDING, OR BY ANY INFORMATION STORAGE AND RETRIEVAL SYSTEM, WITHOUT THE WRITTEN PERMISSION OF HEYRON-HUMANOFF ARCHITECTS, INC.